

YANMAR

SERVICE MANUAL

INDUSTRIAL ENGINES

3TNV88C

3TNV86CT

4TNV88C

4TNV86CT

4TNV98C

4TNV98CT

California
Proposition 65 Warning

Diesel engine exhaust and some of its constituents are known to the state of California to cause cancer, birth defects, and other reproductive harm.

California
Proposition 65 Warning

Battery posts, terminals, and related accessories contain lead and lead compounds, chemicals known to the state of California to cause cancer and reproductive harm.
Wash hands after handling.

Foreword:

This Service Manual has been developed for the exclusive use of service and repair professionals such as YANMAR authorized distributors and YANMAR authorized dealers. It is written with these professionals in mind and may not contain the necessary detail or safety statements that may be required for a non-professional to perform the service or repair properly and/or safely. Please contact an authorized YANMAR repair or service professional before working on your YANMAR product.

Disclaimers:

All information, illustrations and specifications in this manual are based on the latest information available at the time of publishing. The illustrations used in this manual are intended as representative reference views only. Moreover, because of our continuous product improvement policy, we may modify information, illustrations and/or specifications to explain and/or exemplify a product, service or maintenance improvement. We reserve the right to make any change at any time without notice. YANMAR and **YANMAR** are registered trademarks of YANMAR CO., LTD. in Japan, the United States and/or other countries.

All Rights Reserved:

No part of this publication may be reproduced or used in any form by any means - graphic, electronic, or mechanical, including photocopying, recording, taping, or information storage and retrieval systems - without the written permission of YANMAR CO., LTD.

SERVICE MANUAL	Model	TNV Series
	Code No.	0BTN4-G00200

TABLE OF CONTENTS

	Page
Introduction	1-1
YANMAR Warranties	2-1
Safety.....	3-1
General Service Information	4-1
Periodic Maintenance	5-1
Engine	6-1
Fuel System	7-1
Cooling System	8-1
Lubrication System	9-1
Turbocharger	10-1
Starter Motor.....	11-1
Alternator	12-1
Electronic Control System	13-1
Electric Wiring	14-1
Failure Diagnosis	15-1

This Page Intentionally Left Blank

Section 1

INTRODUCTION

This Service Manual describes the service procedures for the TNV series engines have common rail injection system. These engines are certified by the U.S. EPA, California ARB and/or the 97/68/EC Directive for industrial use.

Please use this manual for accurate, quick and safe servicing of the engine. Since the directions in this manual are for a typical engine, some specifications and components may be different from your engine. Refer to the documentation supplied by the optional equipment manufacturer for specific service instructions.

For the replacement of some parts and troubleshooting for the TNV series engines, the YANMAR Diagnostics Tool called SMARTASSIST-Direct is required. In addition, please read both Troubleshooting Manual and SMARTASSIST-Direct Operation Manual.

YANMAR products are continuously undergoing improvement. This Service Manual might not address possible field modifications to the equipment. Contact an authorized YANMAR industrial engine dealer or distributor for answers to any questions relating to field modifications.

This Page Intentionally Left Blank

Section 2

YANMAR WARRANTIES

	Page
YANMAR Limited Warranty	2-3
What is Covered by this Warranty?	2-3
How Long is the Warranty Period?	2-3
What the Engine Owner must Do:	2-3
To Locate an Authorized YANMAR Industrial Engine Dealer or Distributor:	2-4
What YANMAR will Do:	2-4
What is not Covered by this Warranty?	2-4
Warranty Limitations:	2-5
Warranty Modifications:	2-5
Questions:	2-5
Emission System Warranty	2-6
YANMAR Co., Ltd. Limited Emission Control System Warranty - USA Only	2-6
Your Warranty Rights and Obligations:	2-6
Manufacturer's Warranty Period:.....	2-6
Warranty Coverage:	2-7
Warranted Parts:	2-7
Exclusions:	2-8
Owner's Warranty Responsibilities:.....	2-8

This Page Intentionally Left Blank

YANMAR LIMITED WARRANTY

What is Covered by this Warranty?

YANMAR warrants to the original retail purchaser that a new YANMAR TNV series industrial engine will be free from defects in material and/or workmanship for the duration of the warranty period.

Note: YANMAR engines may be equipped with external components including, but not limited to: wiring harnesses, electrical devices, control panels, radiators, air filters, fuel filters, and/or exhaust systems that are supplied and/or installed by manufacturers other than YANMAR. For warranty information on such external components, please contact the machine or component manufacturer directly or see your authorized YANMAR dealer or distributor.

This warranty is provided in lieu of all other warranties, express or implied. YANMAR specifically disclaims any implied warranties of merchantability or fitness for a particular purpose, except where such disclaimer is prohibited by law. If such disclaimer is prohibited by law, then implied warranties shall be limited in duration to the life of the express warranty.

How Long is the Warranty Period?

The YANMAR standard limited warranty period runs for a period of **twenty-four (24) months or two-thousand (2000) engine operation hours**, whichever occurs first. An extended limited warranty of thirty-six (36) months or three thousand (3000) engine operating hours, whichever occurs first, is provided for these specific parts only: the cylinder block, cylinder head, crankshaft forging, connecting rods, flywheel, flywheel housing, camshaft, timing gear, and gear case. The warranty period for both the standard limited warranty and the extended limited warranty (by duration or operation hours) begins on the date of delivery to the original retail purchaser and is valid only until the applicable warranted duration has passed or the operation hours are exceeded, whichever comes first.

What the Engine Owner must Do:

If you believe your YANMAR engine has experienced a failure due to a defect in material and/or workmanship, you must contact an authorized YANMAR industrial engine dealer or distributor within thirty (30) days of discovering the failure. You must provide proof of ownership of the engine, proof of the date of the engine purchase and delivery, and documentation of the engine operation hours. Acceptable forms of proof of delivery date include, but are not limited to: the original warranty registration or sales receipts or other documents maintained in the ordinary course of business by YANMAR dealers and/or distributors, indicating the date of delivery of the YANMAR product to the original retail purchaser. This information is necessary to establish whether the YANMAR product is still within the warranty period. Thus, YANMAR strongly recommends you register your engine as soon as possible after purchase in order to facilitate any future warranty matters.

You are responsible for the transportation of the engine to and from the repair location as designated by YANMAR.

YANMAR limited warranty - continued**To Locate an Authorized YANMAR Industrial Engine Dealer or Distributor:**

You can locate your nearest authorized YANMAR industrial engine dealer or distributor by visiting the YANMAR Co., Ltd. website at:

<http://www.yanmar.co.jp> (The Japanese language page will be displayed.) For English language “click” on “English Page.”)

- “Click” on “Network” in the website heading to view the “Yanmar Worldwide Network.”
- Choose and “Click” on the desired product group.
- “Click” on the Icon closest to your region.
- “Click” on the desired country or associate company to locate your nearest authorized YANMAR industrial engine dealer or distributor.
- You may also contact YANMAR by clicking on “Inquiry” in the website heading and typing in your question or comment.

What YANMAR will Do:

YANMAR warrants to the original retail purchaser of a new YANMAR engine that YANMAR will make such repairs and/or replacements at YANMAR’s option, of any part(s) of the YANMAR product covered by this warranty found to be defective in material and/or workmanship. Such repairs and/or replacements will be made at a location designated by YANMAR at no cost to the purchaser for parts or labor.

What is not Covered by this Warranty?

This warranty does not cover parts affected by or damaged by any reason other than defective materials or workmanship including, but not limited to, accident, misuse, abuse, “Acts of God,” neglect, improper installation, improper maintenance, improper storage, the use of unsuitable attachments or parts, the use of contaminated fuels, the use of fuels, oils, lubricants, or fluids other than those recommended in your YANMAR Operation Manual, unauthorized alterations or modifications, ordinary wear and tear, and rust or corrosion. This warranty does not cover the cost of parts and/or labor required to perform normal/scheduled maintenance on your YANMAR engine. This warranty does not cover consumable parts such as, but not limited to, filters, belts, hoses, fuel injector nozzles, lubricants and cleaning fluids. This warranty does not cover the cost of shipping the product to or from the warranty repair facility.

*YANMAR limited warranty - continued***Warranty Limitations:**

The foregoing is YANMAR's only obligation to you and your exclusive remedy for breach of warranty. Failure to follow the requirements for submitting a claim under this warranty may result in a waiver of all claims for damages and other relief. **In no event shall YANMAR or any authorized industrial engine dealer or distributor be liable for incidental, special or consequential damages.** Such consequential damages may include, but not be limited to, loss of revenue, loan payments, cost of rental of substitute equipment, insurance coverage, storage, lodging, transportation, fuel, mileage, and telephone costs. The limitations in this warranty apply regardless of whether your claims are based on breach of contract, tort (including negligence and strict liability) or any other theory. Any action arising hereunder must be brought within one (1) year after the cause of action accrues or it shall be barred. Some states and countries do not allow certain limitations on warranties or for breach of warranties. **This warranty gives you specific legal rights, and you may also have other rights which vary from state to state and country to country.** Limitations set forth in this paragraph shall not apply to the extent that they are prohibited by law.

Warranty Modifications:

Except as modified in writing and signed by the parties, this warranty is and shall remain the complete and exclusive agreement between the parties with respect to warranties, superseding all prior agreements, written and oral, and all other communications between the parties relating to warranties. **No person or entity is authorized to give any other warranty or to assume any other obligation on behalf of YANMAR, either orally or in writing.**

Questions:

If you have any questions or concerns regarding this warranty, please call or write to the nearest authorized YANMAR industrial engine dealer or distributor or other authorized facility.

EMISSION SYSTEM WARRANTY

YANMAR CO., LTD. LIMITED EMISSION CONTROL SYSTEM WARRANTY - USA ONLY

Your Warranty Rights and Obligations:

■ California

The California Air Resources Board (CARB), the Environmental Protection Agency (EPA) and YANMAR Co., Ltd. hereafter referred to as YANMAR, are pleased to explain the **emission control system warranty** on your industrial compression-ignition engine. In California, model year 2000 or later off-road compression-ignition engines must be designed, built and equipped to meet the state's stringent anti-smog standards. In all states, 1998 and later non-road compression-ignition engines must be designed, built and equipped to meet the United States EPA emissions standards. YANMAR warrants the emission control system on your engine for the periods of time listed below provided there has been no abuse, neglect or improper maintenance of your engine.

Your emission control system may include parts such as the fuel injection system, Electronic Control Unit, Exhaust Gas Recirculation (EGR) system, after treatment system (DPF) and the air induction system. Also included may be hoses, belts, connectors and other emission-related assemblies.

Where a warrantable condition exists, YANMAR will repair your non-road compression-ignition engine at no charge to you including diagnosis, parts and labor.

Manufacturer's Warranty Period:

The model year 1998 or later certified and labeled non-road compression-ignition engines are warranted for the periods listed below. If any emission-related part on your engine is found to be defective during the applicable warranty period, the part will be replaced by YANMAR.

If your engine is certified as	And its maximum power is	And its rated speed is	Then its warranty period is
Variable speed or constant speed	kW < 19	Any speed	1,500 hours or two (2) years whichever comes first. In the absence of a device to measure the hours of use, the engine has a warranty period of two (2) years.
Constant speed	19 ≤ kW < 37	3,000 rpm or higher	1,500 hours or two (2) years whichever comes first. In the absence of a device to measure the hours of use, the engine has a warranty period of two (2) years.
Constant speed	19 ≤ kW < 37	Less than 3,000 rpm	3,000 hours or five (5) years whichever comes first. In the absence of a device to measure the hours of use, the engine has a warranty period of five (5) years.
Variable speed	19 ≤ kW < 37	Any speed	3,000 hours or five (5) years whichever comes first. In the absence of a device to measure the hours of use, the engine has a warranty period of five (5) years.
Variable speed or constant speed	kW ≥ 37	Any speed	3,000 hours or five (5) years whichever comes first. In the absence of a device to measure the hours of use, the engine has a warranty period of five (5) years.

Limited emission control system warranty - USA only - continued**Warranty Coverage:**

This warranty is transferable to each subsequent purchaser for the duration of the warranty period. Repair or replacement of any warranted part will be performed at an authorized YANMAR industrial engine dealer or distributor.

Warranted parts not scheduled for replacement as required maintenance in the operation manual shall be warranted for the warranty period. Warranted parts scheduled for replacement as required maintenance in the operation manual are warranted for the period of time prior to the first scheduled replacement. Any part repaired or replaced under warranty shall be warranted for the remaining warranty period.

During the warranty period, YANMAR is liable for damages to other engine components caused by the failure of any warranted part during the warranty period.

Any replacement part which is functionally identical to the original equipment part in all respects may be used in the maintenance or repair of your engine, and shall not reduce YANMAR's warranty obligations. Add-on or modified parts that are not exempted may not be used. The use of any non-exempted add-on or modified parts shall be grounds for disallowing a warranty.

Warranted Parts:

This warranty covers engine components that are a part of the emission control system of the engine as delivered by YANMAR to the original retail purchaser. Such components may include the following:

- Fuel injection system
- Electronic control system
- Cold start enrichment system
- Intake manifold
- Turbocharger systems
- Exhaust manifold
- EGR system
- Positive crankcase ventilation system
- After treatment system (Diesel Particulate Filter)
- Hoses, belts, connectors and assemblies associated with emission control systems

Since emissions-related parts may vary slightly between models, certain models may not contain all of these parts and other models may contain the functional equivalents.

Limited emission control system warranty - USA only - continued**Exclusions:**

Failures other than those arising from defects in material and/or workmanship are not covered by this warranty. The warranty does not extend to the following: malfunctions caused by abuse, misuse, improper adjustment, modification, alteration, tampering, disconnection, improper or inadequate maintenance or use of non-recommended fuels and lubricating oils; accident-caused damage, and replacement of expendable items made in connection with scheduled maintenance. YANMAR disclaims any responsibility for incidental or consequential damages such as loss of time, inconvenience, loss of use of equipment/engine or commercial loss.

Owner's Warranty Responsibilities:

As the engine owner, you are responsible for the performance of the required maintenance listed in your owner's manual. YANMAR recommends that you retain all documentation, including receipts, covering maintenance on your non-road compression-ignition engine, but YANMAR cannot deny warranty solely for the lack of receipts, or for your failure to ensure the performance of all scheduled maintenance.

YANMAR may deny your warranty coverage of your non-road compression-ignition engine if a part has failed due to abuse, neglect, improper maintenance or unapproved modifications.

Your engine is designed to operate on diesel fuel only. Use of any other fuel may result in your engine no longer operating in compliance with applicable emissions requirements.

You are responsible for initiating the warranty process. You must present your engine to a YANMAR dealer as soon as a problem exists. The warranty repairs should be completed by the dealer as expeditiously as possible. If you have any questions regarding your warranty rights and responsibilities, or would like information on the nearest YANMAR dealer or authorized service center, you should contact YANMAR America Corporation at 1-800-872-2867.

Section 3

SAFETY

	Page
Safety Statements	3-3
Safety Precautions	3-4

This Page Intentionally Left Blank

SAFETY STATEMENTS

YANMAR is concerned for your safety and your machine's condition. Safety statements are one of the primary ways to call your attention to the potential hazards associated with YANMAR TNV engine operation. Follow the precautions listed throughout the manual before operation, during operation and during periodic maintenance procedures for your safety, the safety of others and to protect the performance of your engine. Keep the labels from becoming dirty or torn and replace them if they are lost or damaged. Also, if you need to replace a part that has a label attached to it, make sure you order the new part and label at the same time.



This safety alert symbol appears with most safety statements. It means attention, become alert, your safety is involved! Please read and abide by the message that follows the safety alert symbol.

DANGER

DANGER indicates a hazardous situation which, if not avoided, *will* result in death or serious injury.

WARNING

WARNING indicates a hazardous situation which, if not avoided, *could* result in death or serious injury.

CAUTION

CAUTION indicates a hazardous situation which, if not avoided, *could* result in minor or moderate injury.

NOTICE

NOTICE indicates a situation which can cause damage to the machine, personal property and/or the environment or cause the equipment to operate improperly.

SAFETY PRECAUTIONS

⚠ DANGER**High Pressure Hazard!**

- This engine uses a high-pressure common rail system. For disassembly of the highpressure parts (e.g. the high-pressure pipe) in particular, be sure to wait approximately 10 to 15 minutes before performing disassembly.
- Do not loosen the high pressure pipe while the engine is running, even in low idle. This is dangerous because fuel under high pressure will blow out.
- Failure to comply will result in death or serious injury.

⚠ DANGER**Scald Hazard!**

- Never remove the radiator cap if the engine is hot. Steam and hot engine coolant will spurt out and seriously burn you. Allow the engine to cool down before you attempt to remove the radiator cap.
- Tighten the radiator cap securely after you check the radiator. Steam can spurt out during engine operation if the cap is loose.
- Always check the level of the engine coolant by observing the reserve tank.
- Failure to comply will result in death or serious injury.

⚠ DANGER**Explosion Hazard!**

- Keep the area around the battery well-ventilated. While the engine is running or the battery is charging, hydrogen gas is produced which can be easily ignited.
- Keep sparks, open flame and any other form of ignition away while the engine is running or battery is charging.
- Never check the remaining battery charge by shorting out the terminals. This will result in a spark and may cause an explosion or fire. Use a hydrometer to check the remaining battery charge.
- If the electrolyte is frozen, slowly warm the battery before you recharge it.
- Failure to comply will result in death or serious injury.

⚠ DANGER**Fire and Explosion Hazard!**

- Diesel fuel is flammable and explosive under certain conditions.

- When you remove any fuel system component to perform maintenance (such as changing the fuel filter) place an approved container under the opening to catch the fuel.
- Never use a shop rag to catch the fuel. Vapors from the rag are flammable and explosive.
- Wipe up any spills immediately.
- Wear eye protection. The fuel system is under pressure and fuel could spray out when you remove any fuel system component.
- Only use the key switch to start the engine.
- Never jump-start the engine. Sparks caused by shorting the battery to the starter terminals may cause a fire or explosion.
- If the unit has an electric fuel pump, when you prime the fuel system, turn the key switch to the ON position for 10 to 15 seconds to allow the electric fuel pump to prime the system.
- If the unit has a mechanical fuel pump, when you prime the fuel system, operate the fuel priming lever of the mechanical fuel pump several times until the fuel filter cup is filled with fuel.
- Only fill the fuel tank with diesel fuel. Filling the fuel tank with gasoline may result in a fire and will damage the engine.
- Never refuel with the engine running.
- Keep sparks, open flames or any other form of ignition (match, cigarette, static electric source) well away when refueling.
- Never overfill the fuel tank.
- Fill the fuel tank. Store any containers containing fuel in a well-ventilated area, away from any combustibles or sources of ignition.

⚠ DANGER

(Continued)

- Be sure to place the diesel fuel container on the ground when transferring the diesel fuel from the pump to the container. Hold the hose nozzle firmly against the side of the container while filling it. This prevents static electricity buildup which could cause sparks and ignite fuel vapors.
- Never place diesel fuel or other flammable material such as oil, hay or dried grass close to the engine during engine operation or shortly after shutdown.
- Before you operate the engine, check for fuel leaks. Replace rubberized fuel hoses every two years or every 2000 hours of engine operation, whichever comes first, even if the engine has been out of service. Rubberized fuel lines tend to dry out and become brittle after two years or 2000 hours of engine operation, whichever comes first.
- Never remove the fuel cap with the engine running.
- Never use diesel fuel as a cleaning agent.
- Place an approved container under the air bleed port when you prime the fuel system. Never use a shop rag to catch the fuel. Wipe up any spills immediately. Always close the air bleed port after you complete priming the system.
- Wear eye protection. The fuel system is under pressure and fuel could spray out when you open the air bleed port.
- If the unit has an electric fuel pump, turn the key switch to the ON position for 10 to 15 seconds, or until the fuel coming out of the air bleed port is free of bubbles, to allow the electric fuel pump to prime the system.
- If the unit has a mechanical fuel pump, operate the fuel priming pump several times until the fuel coming out of the air bleed port is free of bubbles.
- Failure to comply will result in death or serious injury.

⚠ DANGER**Crush Hazard!**

- When you need to transport an engine for repair, have a helper assist you to attach it to a hoist and load it on a truck.
- Never stand under a hoisted engine. If the hoist mechanism fails, the engine will fall on you, causing death or serious injury.
- Failure to comply will result in death or serious injury.

⚠ WARNING**Sever Hazard!**

- Keep hands and other body parts away from moving/rotating parts such as the cooling fan, flywheel or PTO shaft.
- Wear tight-fitting clothing and keep your hair short or tie it back while the engine is running.
- Remove all jewelry before you operate or service the machine.
- Never start the engine in gear. Sudden movement of the engine and/or machine could cause death or serious personal injury.
- Never operate the engine without the guards in place.
- Before you start the engine make sure that all bystanders are clear of the area.
- Keep children and pets away while the engine is operating.
- Check before starting the engine that any tools or shop rags used during maintenance have been removed from the area.
- Failure to comply could result in death or serious injury.

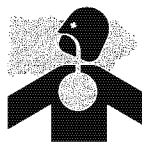
⚠ WARNING**Exhaust Hazard!**

- Never operate the engine in an enclosed area such as a garage, tunnel, underground room, manhole or ship's hold without proper ventilation.
- Never block windows, vents, or other means of ventilation if the engine is operating in an enclosed area. All internal combustion engines create carbon monoxide gas during operation. Accumulation of this gas within an enclosure could cause illness or even death.
- Make sure that all connections are tightened to specifications after repair is made to the exhaust system.
- Failure to comply could result in death or serious injury.

⚠ WARNING**Alcohol and Drug Hazard!**

- Never operate the engine while you are under the influence of alcohol or drugs.
- Never operate the engine when you are feeling ill.
- Failure to comply could result in death or serious injury.

⚠ WARNING**Exposure Hazard!**

- Wear personal protective equipment such as gloves, work shoes, eye and hearing protection as required by the task at hand.
- Never wear jewelry, unbuttoned cuffs, ties or loose-fitting clothing when you are working near moving/rotating parts such as the cooling fan, flywheel or PTO shaft.
- Always tie back long hair when you are working near moving/rotating parts such as a cooling fan, flywheel, or PTO shaft.
- Never operate the engine while wearing a headset to listen to music or radio because it will be difficult to hear the alert signals.
- Failure to comply could result in death or serious injury.

⚠ WARNING**Burn Hazard!**

- If you must drain the engine oil while it is still hot, stay clear of the hot engine oil to avoid being burned.
- Always wear eye protection.
- Wait until the engine cools before you drain the engine coolant. Hot engine coolant may splash and burn you.
- Keep your hands and other body parts away from hot engine surfaces such as the muffler, exhaust pipe, turbocharger (if equipped) and engine block during operation and shortly after you shut the engine down. These surfaces are extremely hot while the engine is operating and could seriously burn you.
- Failure to comply could result in death or serious injury.

⚠ WARNING**Burn Hazard!**

- Batteries contain sulfuric acid. Never allow battery fluid to come in contact with clothing, skin or eyes. Severe burns could result. Always wear safety goggles and protective clothing when servicing the battery. If battery fluid contacts the eyes and/or skin, immediately flush the affected area with a large amount of clean water and obtain prompt medical treatment.
- Failure to comply could result in death or serious injury.

⚠ WARNING**High-Pressure Hazard!**

- Avoid skin contact with the high-pressure diesel fuel spray caused by a fuel system leak such as a broken fuel injection line. High-pressure fuel can penetrate your skin and result in serious injury. If you are exposed to high-pressure fuel spray, obtain prompt medical treatment.
- Never check for a fuel leak with your hands. Always use a piece of wood or cardboard. Have your authorized YANMAR industrial engine dealer or distributor repair the damage.
- Failure to comply could result in death or serious injury.

⚠ WARNING**Shock Hazard!**

- Turn off the battery switch (if equipped) or disconnect the negative battery cable before servicing the electrical system.

- Check the electrical harnesses for cracks, abrasions, and damaged or corroded connectors. Always keep the connectors and terminals clean.
- Failure to comply could result in death or serious injury.

⚠ WARNING**Entanglement Hazard!**

- Stop the engine before you begin to service it.

- Never leave the key in the key switch when you are servicing the engine. Someone may accidentally start the engine and not realize you are servicing it. This could result in a serious injury.
- If you must service the engine while it is operating, remove all jewelry, tie back long hair, and keep your hands, other body parts and clothing away from moving/rotating parts.
- Failure to comply could result in death or serious injury.

⚠ WARNING**Sudden Movement Hazard!**

- Engaging the transmission or PTO at an elevated engine speed could result in unexpected movement of the equipment.
- Failure to comply could result in death or serious injury.

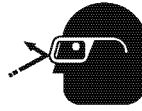
⚠ WARNING

To prevent possible eye injury, always wear safety glasses while servicing the engine.

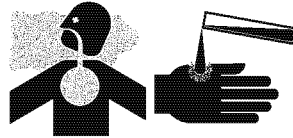
⚠ WARNING**Fume/Burn Hazard!**

- Always read and follow safety related precautions found on containers of hazardous substances like parts cleaners, primers, sealants and sealant removers.

- Failure to comply could result in death or serious injury.

⚠ WARNING

Never apply over 40 PSI (2.8 kgf/cm) to the waste gate actuator.

⚠ WARNING

- Never inject fuel toward you. Since the fuel is injected at high pressure from the nozzle, it may penetrate the skin, resulting in injury.
- Never inject fuel toward a fire source. Atomized fuel is highly flammable and may cause a fire or burn skin.

⚠ WARNING

- Never use the E-ECU for other purposes than intended or in other ways than specified by YANMAR. Doing so could result in the violation of emission control regulations and will void the product warranty.
- Improper use or misuse of the E-ECU may result in death or serious injury due to an abrupt and unexpected increase in engine speed.

⚠ WARNING

- Be sure to use the E-ECU in conjunction with the engines whose models or serial numbers are specified by YANMAR. Other E-ECU/engine combinations than specified will void the engine warranty.
- Improper use or misuse of the E-ECU may result in death or serious injury due to an abrupt and unexpected increase in engine speed.

⚠ WARNING

- Replacing the fuel injector involves rewriting the injector trim data in the E-ECU. Be sure to contact your local YANMAR dealer before replacing the fuel injector. Failure to rewrite the injector trim data before replacing the fuel injector will void the engine warranty.
- Improper use or misuse of the E-ECU may result in death or serious injury due to an abrupt and unexpected increase in engine speed.

⚠ WARNING

- Replacing the E-ECU involves migrating the fuel injection data to the existing E-ECU to the new unit. Be sure to contact your local YANMAR dealer before replacing the E-ECU. Failure to migrate the fuel injection data before replacing the E-ECU will void the engine warranty.
- Improper use or misuse of the E-ECU may result in death or serious injury due to an abrupt and unexpected increase in engine speed.

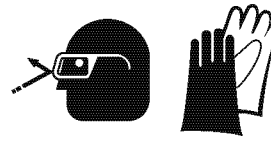
⚠ CAUTION**Coolant Hazard!**

- Wear eye protection and rubber gloves when you handle long life or extended life engine coolant. If contact with the eyes or skin should occur, flush eyes and wash immediately with clean water.

- Failure to comply may result in minor or moderate injury.

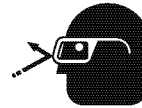
⚠ CAUTION**Flying Object Hazard!**

- Always wear eye protection when servicing the engine and when using compressed air or high-pressure water. Dust, flying debris, compressed air, pressurized water or steam may injure your eyes.

- Failure to comply may result in minor or moderate injury.

⚠ CAUTION

Be sure to secure the engine solidly to prevent injury or damage to parts due to the engine falling during work on the engine.

⚠ CAUTION**Pinch Hazard!**

Carefully rotate the alternator toward the cylinder block while loosening the V-belt. Failure to comply may result in minor or moderate injury.

⚠ CAUTION

If any oil pump component clearance exceeds its limit, the oil pump must be replaced as an assembly.

NOTICE

- Only use diesel fuels recommended by YANMAR for the best engine performance, to prevent engine damage and to comply with EPA/ARB warranty requirements.
- Only use clean diesel fuel.
- Never remove the primary strainer (if equipped) from the fuel tank filler port. If removed, dirt and debris could get into the fuel system causing it to clog.

NOTICE

Never attempt to adjust the low or high idle speed limit screw. This may impair the safety and performance of the machine and shorten its life. If adjustment is ever required, contact your authorized YANMAR industrial engine dealer or distributor.

NOTICE

If any problem is noted during the visual check, the necessary corrective action should be taken before you operate the engine.

NOTICE

Never hold the key in the START position for longer than 15 seconds or the starter motor will overheat.

NOTICE

If the engine start fails, wait 30 seconds before you start the engine again.

NOTICE

Make sure the engine is installed on a level surface. If a continuously running engine is installed at an angle greater than (30°) in any direction or if an engine runs for short periods of time (less than three minutes) at an angle greater than (35°) in any direction, engine oil may enter the combustion chamber causing excessive engine speed and white exhaust smoke. This may cause serious engine damage.

NOTICE

Observe the following environmental operating conditions to maintain engine performance and avoid premature engine wear:

- Avoid operating in extremely dusty conditions.
- Avoid operating in the presence of chemical gases or fumes.
- Avoid operating in a corrosive atmosphere such as salt water spray.
- Never install the engine in a floodplain unless proper precautions are taken to avoid being subject to a flood.
- Never expose the engine to the rain.

NOTICE

Observe the following environmental operating conditions to maintain engine performance and avoid premature engine wear:

- The standard range of ambient temperatures for the normal operation of YANMAR engines is from +5 °F (-15 °C) to +113 °F (+45 °C).
- If the ambient temperature exceeds +113 °F (+45 °C) the engine may overheat and cause the engine oil to break down.
- If the ambient temperature is below +5 °F (-15 °C) the engine will be hard to start and the engine oil may not flow easily.
- Contact your authorized YANMAR industrial engine dealer or distributor if the engine will be operated outside of this standard temperature range.

NOTICE

The illustrations and descriptions of optional equipment in this manual, such as the operator's console, are for a typical engine installation. Refer to the documentation supplied by the optional equipment manufacturer for specific operation and maintenance instructions.

NOTICE

If any indicator illuminates during engine operation, stop the engine immediately. Determine the cause and repair the problem before you continue to operate the engine.

NOTICE

- Only use the engine oil specified. Other engine oils may affect warranty coverage, cause internal engine components to seize and/or shorten engine life.
- Prevent dirt and debris from contaminating the engine oil. Carefully clean the oil cap/dipstick and the surrounding area before you remove the cap.
- Never mix different types of engine oil. This may adversely affect the lubricating properties of the engine oil.
- Never overfill. Overfilling may result in white exhaust smoke, engine overspeed or internal damage.

NOTICE

- Only use the engine coolant specified. Other engine coolants may affect warranty coverage, cause an internal buildup of rust and scale and/or shorten engine life.
- Prevent dirt and debris from contaminating the engine coolant. Carefully clean the radiator cap and the surrounding area before you remove the cap.
- Never mix different types of engine coolants. This may adversely affect the properties of the engine coolant.

NOTICE

- Never overfill the engine with engine oil.
- Always keep the oil level between the upper and lower lines on the oil cap/dipstick.

NOTICE

For maximum engine life, YANMAR recommends that when shutting the engine down, you allow the engine to idle, without load, for five minutes. This will allow the engine components that operate at high temperatures, such as the turbocharger (if equipped) and exhaust system, to cool slightly before the engine itself is shut down.

NOTICE

Never use an engine starting aid such as ether. Engine damage will result.

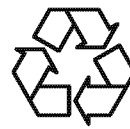
NOTICE

- Always be environmentally responsible.

- Follow the guidelines of the EPA or other governmental agencies for the proper disposal of hazardous materials such as engine oil, diesel fuel and engine coolant. Consult the local authorities or reclamation facility.
- Never dispose of hazardous materials irresponsibly by dumping them into a sewer, on the ground, or into ground water or waterways.
- Failure to follow these procedures may seriously harm the environment.

NOTICE

Never engage the starter motor while the engine is running. This may damage the starter motor pinion and/or ring gear.

NOTICE

New engine break-in:

- On the initial engine start-up, allow the engine to idle for approximately 15 minutes while you check for proper engine oil pressure, diesel fuel leaks, engine oil leaks, coolant leaks, and for proper operation of the indicators and/or gauges.
- During the first hour of operation, vary the engine speed and the load on the engine. Short periods of maximum engine speed and load are desirable. Avoid prolonged operation at minimum or maximum engine speeds and loads for the next four to five hours.
- During the break-in period, carefully observe the engine oil pressure and engine temperature.
- During the break-in period, check the engine oil and coolant levels frequently.

NOTICE

- Never attempt to modify the engine's design or safety features such as defeating the engine speed limit control or the fuel injection quantity control.
- Failure to comply may impair the engine's safety and performance characteristics and shorten the engine's life. Any alterations to this engine may affect the warranty coverage of your engine. See *YANMAR Limited Warranty in Warranty Section*.

NOTICE

Protect the air cleaner, turbocharger (if equipped) and electric components from damage when you use steam or high-pressure water to clean the engine.

NOTICE

Never use high-pressure water or compressed air at greater than 28 PSI (193 kPa; 19686 mmAq) or a wire brush to clean the radiator fins. Radiator fins damage easily.

NOTICE

The tightening torque in the *Standard Torque Chart* (see *General Service Information section*) should be applied only to the bolts with a "7" head. (JIS strength classification: 7T)

- Apply 60 % torque to bolts that are not listed.
- Apply 80 % torque when tightened to aluminum alloy.

**NOTICE**

If any indicator fails to illuminate when the key switch is in the ON position, see your authorized YANMAR industrial engine dealer or distributor for service before operating the engine.

NOTICE

Establish a periodic maintenance plan according to the engine application and make sure you perform the required periodic maintenance at the intervals indicated. Failure to follow these guidelines will impair the engine's safety and performance characteristics, shorten the engine's life and may affect the warranty coverage on your engine.

See *YANMAR Limited Warranty in Warranty Section*.

Consult your authorized YANMAR dealer or distributor for assistance when checking items marked with a ●.

NOTICE

If the fuel filter/water separator is positioned higher than the fuel level in the fuel tank, water may not drip out when the fuel filter/water separator drain cock is opened. If this happens, turn the air vent screw on the top of the fuel filter/water separator 2 - 3 turns counterclockwise.

Be sure to tighten the air vent screw after the water has drained out.

NOTICE

- When the engine is operated in dusty conditions, clean the air cleaner element more frequently.
- Never operate the engine with the air cleaner element(s) removed. This may allow foreign material to enter the engine and damage it.

NOTICE

The maximum air intake restriction, in terms of differential pressure measurement, must not exceed 0.90 PSI (6.23 kPa; 635 mmAq). Clean or replace the air cleaner element if the air intake restriction exceeds the above mentioned value.

NOTICE

It is important to perform daily checks.

Periodic maintenance prevents unexpected downtime, reduces the number of accidents due to poor machine performance and helps extend the life of the engine.

NOTICE

If the oil pump must be replaced, replace it as an assembly only. Do not replace individual components.

NOTICE

The starter motor can be damaged if operated continuously longer than 10 seconds while performing the no-load test.

NOTICE

Do not short-circuit the charging system between alternator terminals IG and L. Damage to the alternator will result.

NOTICE

Do not connect a load between alternator terminals L and E. Damage to the alternator will result.

NOTICE

Do not remove the positive (+) battery cable from alternator terminal B while the engine is operating. Damage to the alternator will result.

NOTICE

Do not turn the battery switch OFF while the engine is operating. Damage to the alternator will result.

NOTICE

Do not operate the engine if the alternator is producing unusual sounds. Damage to the alternator will result.

NOTICE

If the engine coolant pump must be replaced, replace the engine coolant pump as an assembly only. Do not attempt to repair the engine coolant pump or replace individual components.

NOTICE

Use a new special O-ring between the engine coolant pump and the joint. Be sure to use the special O-ring for each engine model. Although the O-ring dimensions are the same as a commercially available O-ring, the material is different.

NOTICE

Remove or install the high-pressure fuel injection lines as an assembly whenever possible. Disassembling the high-pressure fuel injection lines from the retainers or bending any of the fuel lines will make it difficult to reinstall the fuel lines.

NOTICE

After marking the position of the pump drive gear, do not rotate the engine crankshaft. Rotating the crankshaft will cause the fuel supply pump to become misaligned.

NOTICE

Do not use a high-pressure wash directly on the alternator. Water will damage the alternator and result in inadequate charging.

NOTICE

Do not reverse the positive (+) and negative (-) ends of the battery cable. The alternator diode and stator coil will be damaged.

NOTICE

When the battery indicator goes out, it should not come on again. The battery indicator only comes on during operation if the alternator fails. However, if an LED is used in the battery indicator, the LED will shine faintly during normal operation.

NOTICE

Using a non-specified V-belt will cause inadequate charging and shorten the belt life. Use the specified belt.

NOTICE

Agricultural or other chemicals, especially those with a high sulfur content, can adhere to the IC regulator. This will corrode the conductor and result in battery over-charging (boiling) and charging malfunctions. Consult YANMAR before using the equipment in such an environment or the warranty is voided.

NOTICE

Make sure that the combined total resistance of the battery cable in both directions between the starter motor and the battery is within the value indicated on the wiring diagram. The starter motor will malfunction or break down if the resistance is higher than the specified value.

NOTICE

The starter motor is water-proofed according to JIS D 0203, R2 which protects the motor from rain or general cleaning. Do not use high-pressure wash or submerge the starter motor in water.

NOTICE

Use a specialized battery charger to recharge a battery with a voltage of 8 volts or less. Booster starting a battery with a voltage of 8 volts or less will generate an abnormally high voltage and destroy electrical equipment.

NOTICE

Make sure that the combined total resistance of the battery cable in both directions between the starter motor and the battery is within the value indicated in the *Battery Cable Resistance chart* in the *Electric Wiring Section* of this manual. The starter motor will malfunction and fail if the resistance is higher than the specified value.

NOTICE

Removing the battery cables or the battery while the engine is operating may cause damage to the current limiter depending on the electrical equipment being used. This situation could cause loss of control of output voltage. The continuous high voltage of 23 - 24 volts (for 5000 min⁻¹ (rpm) dynamo) will damage the current limiter and other electrical equipment.

NOTICE

Reversing the battery cable connections at the battery or on the engine will destroy the SCR diode in the current limiter. This will cause the charging system to malfunction and may cause damage to the electrical harnesses.

NOTICE

Avoid damage to the turbocharger or the engine. Do not spray blower wash fluid or water too quickly.

Use short strokes from a spray bottle to inject blower wash fluid or water into the turbocharger.

Spraying too much wash fluid or water, or spraying too quickly will damage the turbocharger.

NOTICE

Do not allow any material to fall into the oil lines or the oil inlet and outlet ports of the turbocharger.

NOTICE

If the waste valve does not meet specifications, replace the turbocharger or have it repaired by a qualified repair facility.

NOTICE

- Never attempt to modify the engine's design or safety features such as defeating the engine speed limit control or the diesel fuel injection quantity control.
- Modifications may impair the engine's safety and performance characteristics and shorten the engine's life. Any alterations to this engine may void its warranty. Be sure to use YANMAR genuine replacement parts.

NOTICE

Identify all parts and their location using an appropriate method. It is important that all parts are returned to the same position during the reassembly process.

NOTICE

Each pressure adjusting shim removed or added changes the pressure threshold by approximately 275 PSI (1.9 MPa, 19 kgf/cm²). Adding adjusting shims increases the threshold pressure. Removing adjusting shims reduces the pressure threshold.

NOTICE

Keep the piston pin parts, piston assemblies, and connecting rod assemblies together to be returned to the same position during the reassembly process. Label the parts using an appropriate method.

NOTICE

Do not allow the honing tool to operate in one position for any length of time. Damage to the cylinder wall will occur. Keep the tool in constant up-and-down motion.

NOTICE

Any part which is found defective as a result of inspection or any part whose measured value does not satisfy the standard or limit must be replaced.

NOTICE

Any part determined to not meet the service standard or limit before the next service, as determined from the state of current rate of wear, should be replaced even though the part currently meets the service standard limit.

NOTICE

Never use a steel wire brush to clean fuel injectors. Damage to the nozzle and other components is likely to result.

NOTICE

Allow the engine to warm-up for at least five minutes and the idle speed of the engine to return to normal before engaging the transmission or any PTOs. Engaging the transmission or PTO at an elevated engine speed could result in an unexpected movement of the equipment.

NOTICE

Shut down the engine if the fault indicator comes on.

Continuing running the engine with the fault indicator being on may result in a serious malfunction of or damage to the engine, and will void the engine warranty.

NOTICE

Do not energize the starter for a period of longer than 15 seconds.

Take a pause of at least 30 seconds between energization of the starter.

Otherwise the starter could suffer damage.

NOTICE

- High-pressure washing not recommended.
- Avoid using high-pressure washing for electronic or electric devices installed in, on or around the engine, including the E-ECU, relays and harness couplers.

Otherwise such devices may suffer malfunction due to water ingress into them.

NOTICE

Always check the battery for proper charge.

Otherwise the electronically controlled engines may fail to start.

NOTICE

- Do not plug or unplug the E-ECU for a period of at least 6 seconds after power to the unit has been turned on or off.
- Do not touch connector pins of the E-ECU with bare hands. Doing so may result in corrosion of the connector pins and/or damage to the internal circuits of the E-ECU due to static electricity.
- Do not force a measuring probe into the female coupler. Doing so may cause contact failure of the connector pins, resulting in malfunction of the E-ECU.
- Take care to prevent water from entering the couplers when plugging or unplugging the connector. Water inside the couplers may cause corrosion, resulting in malfunction of the E-ECU.
- Avoid plugging/unplugging the connector more than approx. 10 times. Frequent plugging/unplugging of the connector may cause contact failure of the connector pins, resulting in malfunction of the E-ECU.
- Do not use the E-ECU that has ever suffered drop impact.

NOTICE

- Never permit anyone to operate the engine or driven machine without proper training.
- Read and understand this Operation Manual before you operate or service the machine to ensure that you follow safe operating practices and maintenance procedures.
- Machine safety signs and labels are additional reminders for safe operating and maintenance techniques.
- See your authorized YANMAR industrial engine dealer or distributor for additional training.

Section 4

GENERAL SERVICE INFORMATION

	Page
Component Identification.....	4-3
Location of Labels	4-5
Engine Nameplate (Typical)	4-6
Emission Control Regulations	4-6
EPA/ARB Regulations - USA Only	4-6
Emission Control Labels.....	4-6
EPA/CARB labels (Typical)	4-6
The 97/68/EC Directive Certified Engines	4-7
Engine Family.....	4-7
Function of Major Engine Components	4-8
Main Electronic Control Components and Features.....	4-9
Function of Cooling System Components	4-11
Installation Position of Sensors	4-12
Supply Pump	4-13
Rail Pressure Sensor.....	4-13
Crank Rotation Sensor	4-14
Cam Speed Sensor	4-14
Water Temperature Sensor	4-15
New Air Temperature Sensor	4-15
Diesel Particulate Filter (DPF) Intermediate/Inlet, Exhaust Air Temperature Sensor	4-16
Diesel Particulate Filter (DPF) Differential Pressure Sensor ...	4-17
Intake/Exhaust Pressure Sensor	4-18
Intake Air Temperature Sensor	4-18
EGR Gas Temperature Sensor	4-19
EGR Valve.....	4-19

GENERAL SERVICE INFORMATION

Intake Air Throttles	4-20
Acceleration Sensor (YANMAR Standard).....	4-21
Diesel Fuel	4-22
Diesel Fuel Specifications	4-22
Filling The Fuel Tank.....	4-23
Priming the Fuel System	4-24
Engine Oil.....	4-25
Engine Oil Specifications	4-25
Engine Oil Viscosity.....	4-25
Checking Engine Oil.....	4-26
Adding Engine Oil.....	4-26
Engine Oil Capacity (Typical)	4-26
Engine Coolant.....	4-27
Engine Coolant Specifications.....	4-28
Filling Radiator with Engine Coolant	4-28
Engine Coolant Capacity (Typical)	4-29
Specifications	4-30
Description of Model Number.....	4-30
Engine General Specifications	4-30
Principal Engine Specifications	4-31
3TNV88C.....	4-31
3TNV86CT	4-32
4TNV88C.....	4-33
4TNV86CT	4-34
4TNV98C.....	4-35
4TNV98CT	4-36
Set Output Listed by Rotation	4-37
Engine Service Standards.....	4-38
Tightening Torques for Standard Bolts and Nuts	4-39
Abbreviations and Symbols.....	4-41
Unit Conversions.....	4-42

COMPONENT IDENTIFICATION

■ 3TNV88C, 3TNV86CT, 4TNV88C, 4TNV86CT

Figure 4-1 shows where the major engine components are located.

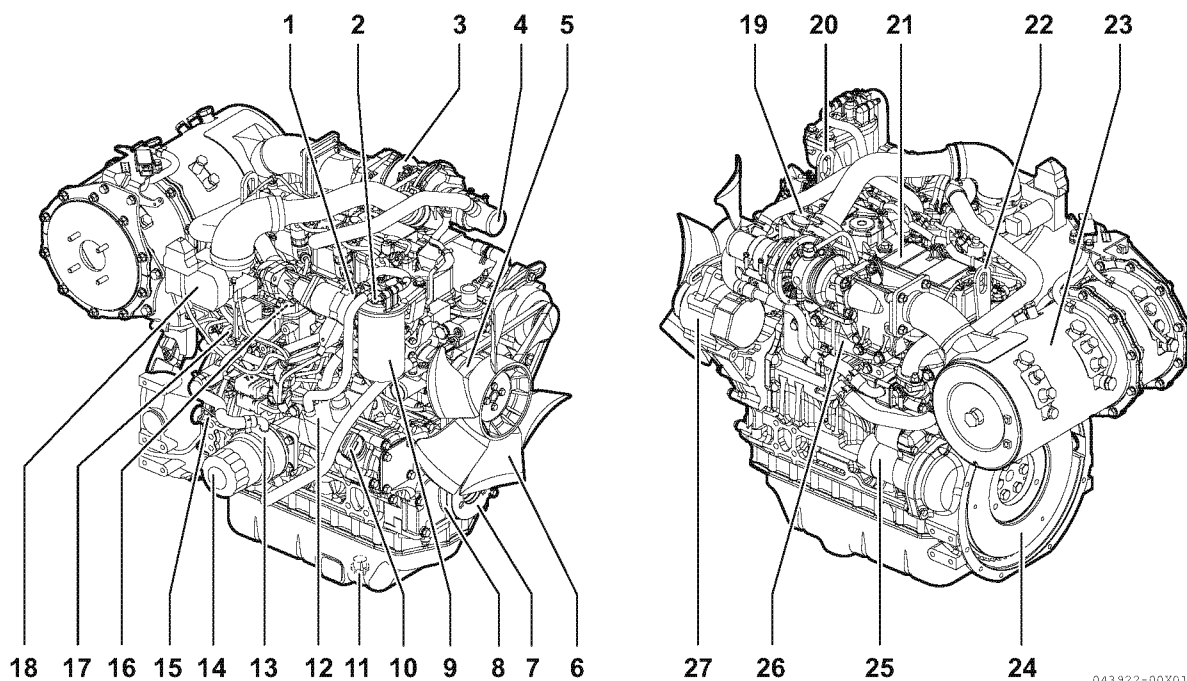

- 1 – Fuel inlet
- 2 – Fuel return to fuel tank
- 3 – Turbocharger*¹
- 4 – Air intake port (from air cleaner)
- 5 – Engine coolant pump
- 6 – Engine cooling fan
- 7 – Crankshaft V-pulley
- 8 – V-belt
- 9 – Fuel filter
- 10 – Side filler port (engine oil)
- 11 – Drain plug (engine oil)*²
- 12 – Supply pump
- 13 – Engine oil cooler
- 14 – Engine oil filter

- 15 – Dipstick (engine oil)
- 16 – Intake manifold
- 17 – Common rail
- 18 – Intake throttle valve
- 19 – Top filler port (engine oil)
- 20 – Lifting eye (engine cooling fan end)
- 21 – Rocker arm cover
- 22 – Lifting eye (flywheel end)
- 23 – Diesel Particulate Filter
- 24 – Flywheel
- 25 – Starter motor
- 26 – Exhaust manifold
- 27 – Alternator

Figure 4-1

*¹ Only applies to 3TNV86CT and 4TNV86CT.

*² The engine oil drain plug location may vary based on oil pan options.

■ 4TNV98C, 4TNV98CT

Figure 4-2 shows where the major engine components are located.

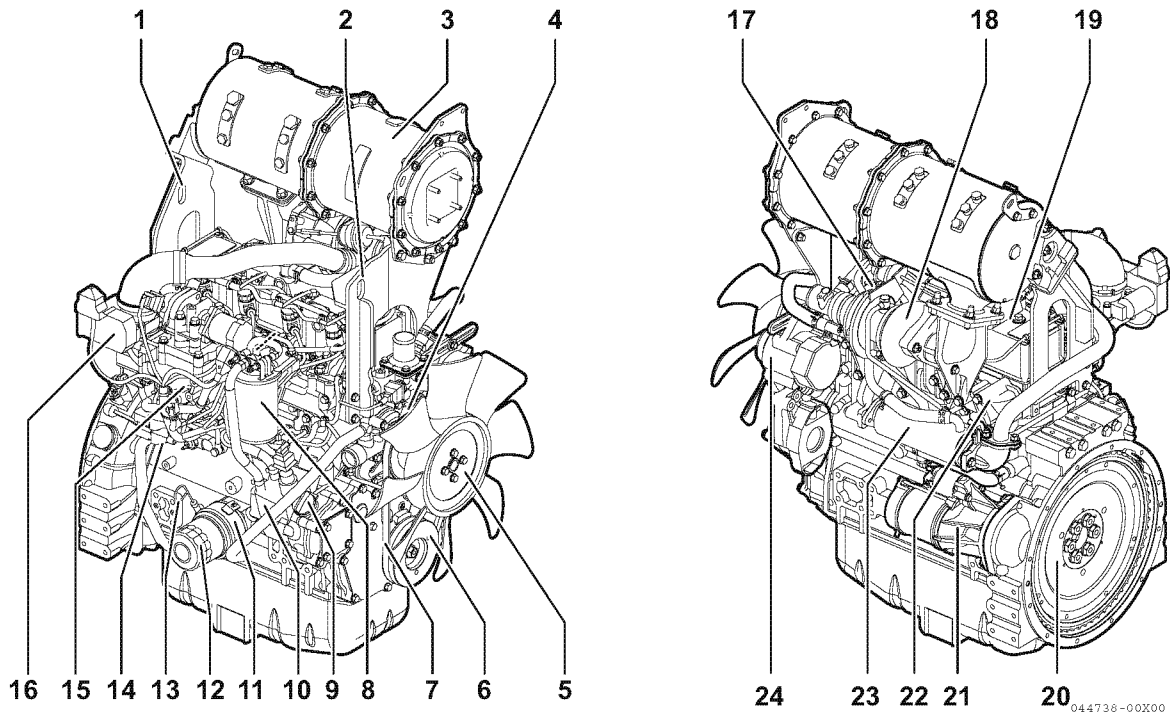

- 1 – Lifting eye (flywheel end)
- 2 – Lifting eye (engine cooling fan end)
- 3 – Diesel Particulate Filter
- 4 – Engine coolant pump
- 5 – Engine cooling fan
- 6 – Crankshaft V-pulley
- 7 – V-belt
- 8 – Fuel filter
- 9 – Side filler port (engine oil)
- 10 – Supply pump
- 11 – Engine oil cooler
- 12 – Engine oil filter

- 13 – Dipstick (engine oil)
- 14 – Drain plug (cooling water)
- 15 – Dipstick (engine oil)
- 16 – Intake throttle valve
- 17 – Top filler port (engine oil)
- 18 – Turbocharger*¹
- 19 – Rocker arm cover
- 20 – Flywheel
- 21 – Starter motor
- 22 – Exhaust manifold
- 23 – EGR cooler
- 24 – Alternator

Figure 4-2

*¹ Only applies to 4TNV98CT.

*² Engine oil drain plug location may vary based on oil pan options.

LOCATION OF LABELS

Figure 4-3 shows the location of regulatory and safety labels on YANMAR TNV series engines.

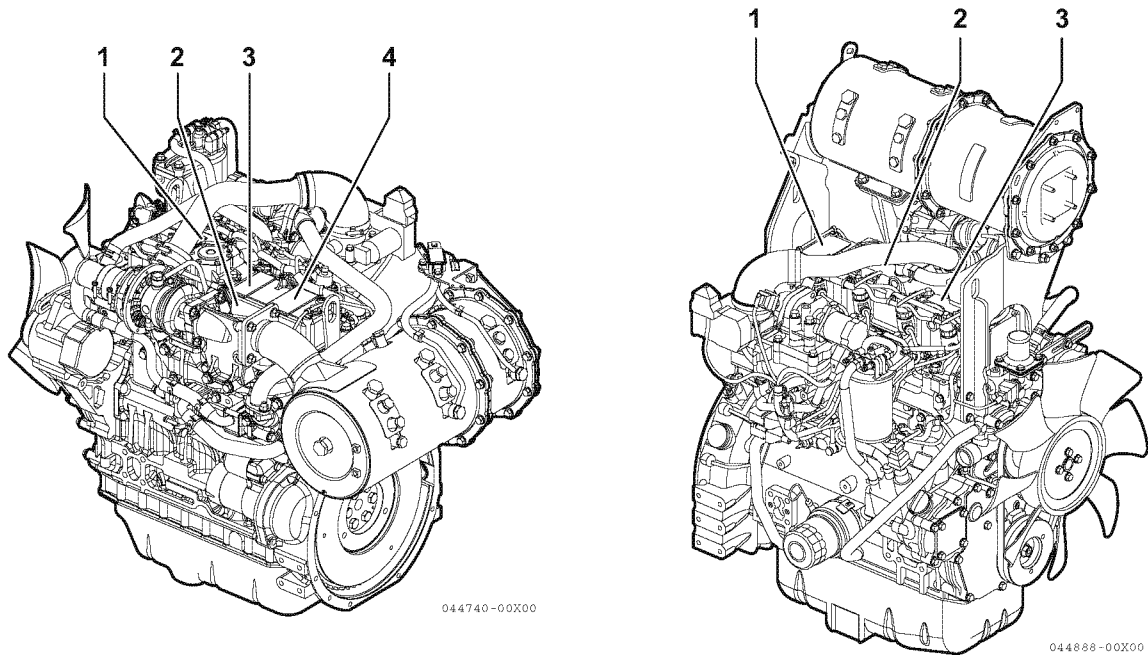
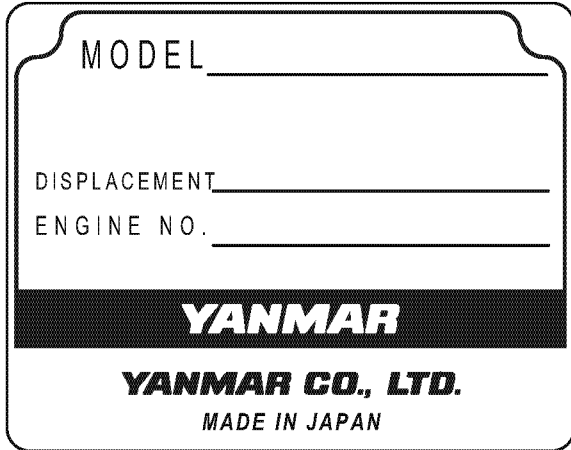

Figure 4-3

■ Location of labels/nameplates on common rail system engine

Model	Engine nameplate	EPA/ARB certification label	97/68/EC emission control label
3TNV88C, 3TNV86CT	On the top of the locker arm cover (cooling fan end) Figure 4-3 left, (1)	On the top of the locker arm cover (flywheel end) Figure 4-3 left, (4)	On the exhaust side of the locker arm cover (near the flywheel) Figure 4-3 left, (2)
4TNV88C, 4TNV86CT	On the top of the locker arm cover (cooling fan end) Figure 4-3 left, (1)	On the top of the locker arm cover (flywheel end) Figure 4-3 left, (4)	On the top of the locker arm cover (center) Figure 4-3 left, (3)
4TNV98C, 4TNV98CT	On the top of the locker arm cover (flywheel end) Figure 4-3 right, (1)	On the top of the locker arm cover (center) Figure 4-3 right, (2)	On the top of the locker arm cover (fan end) Figure 4-3 right, (3)

Engine Nameplate (Typical)



EMISSION CONTROL REGULATIONS

EPA/ARB Regulations - USA Only

YANMAR TNV engines meet Environmental Protection Agency (EPA) (U. S. Federal) emission control standards as well as the California Air Resources Board (ARB, California) regulations. Only engines that conform to ARB regulations can be sold in the State of California.

Refer to the specific EPA/ARB installation (page 5-4) and maintenance (page 5-4) in the *Periodic Maintenance Schedule* section of this manual. Also refer to the *Emission System Warranty* on page 2-6.

EMISSION CONTROL LABELS

Since emission control regulations are being issued on a global basis, it is necessary to identify which regulations a particular engine complies with. We have listed several different types of labels you might find on your engine.

EPA/CARB labels (Typical)

■ EPA

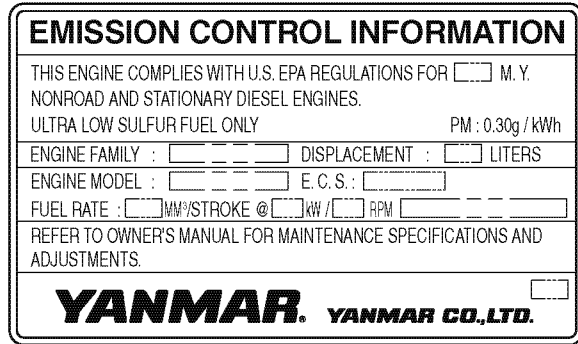

■ EPA and CARB

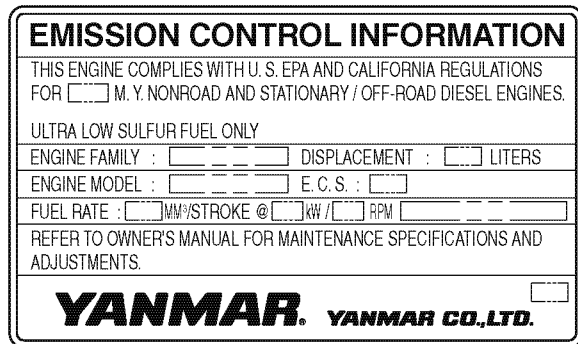

THE 97/68/EC DIRECTIVE CERTIFIED ENGINES

The engines described in this manual have been certified by the 97/68/EC Directive.

To identify the engines that meet this certification, the 97/68/EC emission control label is affixed on the engines.

IMPORTANT ENGINE INFORMATION	
THIS ENGINE CONFORMS TO 97/68/EC DIRECTIVE	
ENGINE FAMILY :	<input type="text"/>
ENGINE MODEL :	<input type="text"/>
APPROVAL NUMBER :	<input type="text"/>
YANMAR CO.,LTD.	

(97/68/EC)

ENGINE FAMILY

The EPA/ARB labels and the 97/68/EC label all have an Engine Family field. The following is an explanation of the Engine Family designation:

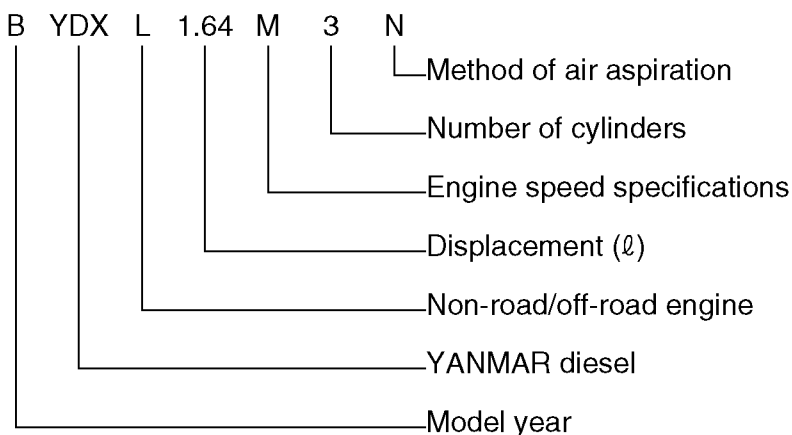

B: 2011

C: 2012

D: 2013

E: 2014

F: 2015

FUNCTION OF MAJOR ENGINE COMPONENTS

Components	Functions
Air cleaner	The air cleaner prevents airborne contaminants from entering the engine. Since the air cleaner is application specific, it must be carefully selected by an application engineer. It is not part of the basic engine package as shipped from the YANMAR factory. Periodic replacement of the air cleaner filter element is necessary. <i>See the Periodic Maintenance Schedule on page 5-5 for the replacement frequency.</i>
Alternator	The alternator is driven by a V-belt which is powered by the crankshaft V-pulley. The alternator supplies electricity to the engine systems and charges the battery while the engine is running.
Dipstick (engine oil)	The engine oil dipstick is used to determine the amount of engine oil in the crankcase.
Electric fuel pump	The electric fuel pump makes sure there is a constant supply of diesel fuel to the fuel injection pump. The electric fuel pump is electro-magnetic and runs on 12 V DC. It must be installed on every application. This is standard equipment with every engine.
Engine oil filter	The engine oil filter removes contaminants and sediments from the engine oil. Periodic replacement of the engine oil filter is necessary. <i>See the Periodic Maintenance Schedule on page 5-5 for the replacement frequency.</i>
Engine oil cooler	The engine oil cooler helps to keep the engine oil cool. Engine coolant from the cooling system is circulated through an adapter at the base of the engine oil filter assembly and then returned to the coolant pump inlet.
Fuel filter	The fuel filter removes contaminants and sediments from the diesel fuel. Periodic replacement of the fuel filter is necessary. <i>See the Periodic Maintenance Schedule on page 5-5 for the replacement frequency.</i> Please note that the word “diesel” is implied throughout this manual when the word “fuel” is used.
Fuel filter/water separator	The fuel filter/water separator removes contaminants, sediments and water from the diesel fuel going to the fuel filter. This is a required component of the fuel system. This is standard equipment with every engine. The separator is installed between the fuel tank and the electric fuel pump. Periodically drain the water from the fuel filter/water separator.
Fuel tank	The fuel tank is a reservoir that holds diesel fuel. When the fuel leaves the fuel tank it goes to the fuel filter/water separator. Next the fuel is pumped to the fuel filter by the electric fuel pump. Then the fuel goes to the fuel injection pump. Since the fuel is used to keep the fuel injection pump cool and lubricated, more fuel than necessary enters the injection pump. When the injection pump pressure reaches a preset value, a relief valve allows the excess fuel to be returned back to the fuel tank. The fuel tank is a required engine component.
Fuel cooler	The fuel cooler prevents the fuel temperature from rising. The fuel cooler is equipped between the fuel filter and the supply pump.
Side and top filler port (engine oil)	You can fill the crankcase with engine oil from either the side or the top filler port depending upon which one is most convenient.
Starter motor	The starter motor is powered by the battery. When you turn the key switch in the operator’s console to the START position, the starter motor engages with the ring gear installed on the flywheel and starts the flywheel in motion.
Turbocharger (only applies to 3TNV86CT, 4TNV86CT, 4TNV98CT)	The turbocharger pressurizes the air coming into the engine. It is driven by a turbine that is energized by exhaust gases.

MAIN ELECTRONIC CONTROL COMPONENTS AND FEATURES

Component/feature	Description
Controller	By controlling the fuel injection timing, injection volume, injection pressure, and number of injection in accordance with the target speed indication entered from the accelerator sensor, the controller adjusts the engine speed and power. Depending on the above-mentioned speed and power, the controller controls the EGR opening. Also, the controller acts as the key station of the application function.
Fuel pump (supply pump)	The fuel pump supplies fuel to the common rail.
Common rail	The common rail stores the compressed high-pressure fuel from the supply pump and distributes fuel to the injector in each cylinder.
Fuel Injector	The Fuel Injectors the high-pressure fuel from the rail to the engine combustion room after receiving a signal from the ECU in the most appropriate injection timing, injection volume, injection ratio, number of injection and spray condition.
EGR valve	Controls the exhaust gas recirculation flow rate depending on the engine speed/load signals from the E-ECU. It is installed on the top of the exhaust manifold.
Accelerator sensor	Unlike mechanical governors, the Eco-governor has no governor lever. The accelerator sensor serves as the governor lever to provide the speed command signal (voltage signal) to the E-ECU for engine speed control. It is installed in the operator cabin of the driven machine. Constant speed engines for e.g. generator use do not require accelerator sensors because the engine speed can be shifted via a switch on the operator's console.
Optional	CAN communication capability is available as an option.
Fault indicator	Is installed on the operator's console. If a fault occurs in the E-ECU or Eco-governor, the fault indicator flashes alerting the operator to a fault. The number of flashes and/or the flashing pattern vary depending on the type or source of the fault, enabling quick-fix.
Optional	
Engine diagnosis tool	Allows the operator to troubleshoot the cause of a problem based on detailed information regarding the problem occurring in the E-ECU or Eco-governor. This tool can also be used for data maintenance tasks including programming and mapping. <i>See Failure Diagnosis on page 15-1.</i>
Option for service	
Engine coolant temperature sensor	Allows the CSD and ERG to be controlled in engine cold-start conditions.

Component/feature		Description
Glow plugs	Optional	When the key switch is turned to the ON position, the glow plugs/air heater are/is energized for up to 15 seconds (glow plugs) or up to 23 seconds (air heater). The duration of energization depends on the engine coolant temperature. The HEAT indicator is on during energization. When the indicator goes out, turn the key switch to the START position to start the engine.
Droop control	Standard with VM series	Reduces the engine speed by a certain percentage from no load to full (rated) load in steady state operation. The same percentage droop is maintained even when the load increases at any no-load speed.
Isochronous control	Standard with CL series Optional with VM series	Offers a constant engine speed from no load to full load. The engine speed does not decrease even when the load increases at any no-load speed.
Low-idling speed up		Increases the low-idling speed to up to 1000 min ⁻¹ (rpm) depending on the engine coolant temperature. When the coolant temperature reaches a predetermined value, this feature returns the engine speed to the normal low idle setting, thus reducing the warm-up time.
High-idling speed down	Optional	Decreases the high-idling speed depending on the engine coolant temperature. When the coolant temperature falls to a predetermined value, this feature returns the engine speed to the normal high idle setting, thus minimizing the emission of white smoke at low temperatures.
Auto deceleration	Optional	Brings the running engine in low idle mode automatically when the accelerator pedal is not operated for a predetermined period of time. When the pedal is operated, i.e., the accelerator sensor is activated, the low idle mode is cancelled.

FUNCTION OF COOLING SYSTEM COMPONENTS

Components	Functions
Cooling system	<p>The TNV engine is liquid-cooled by means of a cooling system. The cooling system consists of a radiator, radiator cap, engine cooling fan, engine coolant pump, thermostat, and reserve tank.</p> <p>Note that all cooling system components are required for proper engine operation. Since some of the components are application specific, they must be carefully selected by an application engineer. The application specific items are not part of the basic engine package as shipped from the YANMAR factory.</p>
• Engine cooling fan	The engine cooling fan is driven by a V-belt which is powered by the crankshaft V-pulley. The purpose of the engine cooling fan is to circulate air through the radiator.
• Engine coolant pump	The engine coolant pump circulates the engine coolant through the cylinder block and the cylinder head and returns the engine coolant to the radiator.
• Radiator	The radiator acts as a heat exchanger. As the engine coolant circulates through the cylinder block it absorbs heat. The heat in the engine coolant is dissipated in the radiator. As the engine cooling fan circulates air through the radiator, the heat is transferred to the air.
• Radiator cap	The radiator cap controls the cooling system pressure. The cooling system is pressurized to raise the boiling point of the engine coolant. As the engine coolant temperature rises, the system pressure and the coolant volume increases. When the pressure reaches a preset value, the release valve in the radiator cap opens and the excess engine coolant flows into the reserve tank. As the engine coolant temperature is reduced, the system pressure and volume is reduced and the vacuum valve in the radiator cap opens allowing the engine coolant to flow from the reserve tank back into the radiator.
• Reserve tank	The reserve tank contains the overflow of engine coolant from the radiator. If you need to add engine coolant to the system, add it to the reserve tank; not the radiator.
• Thermostat	A thermostat is placed in the cooling system to prevent the engine coolant from circulating into the radiator until the engine coolant temperature reaches a preset temperature. When the engine is cold, no engine coolant flows through the radiator. Once the engine reaches its operating temperature, the thermostat opens and allows the engine coolant to flow through the radiator. By letting the engine warm up as quickly as possible, the thermostat reduces engine wear, deposits and emissions.

INSTALLATION POSITION OF SENSORS

Do not unnecessarily touch the sensor coupler portion with your bare hands.
The sensor may be damaged due to static electricity.

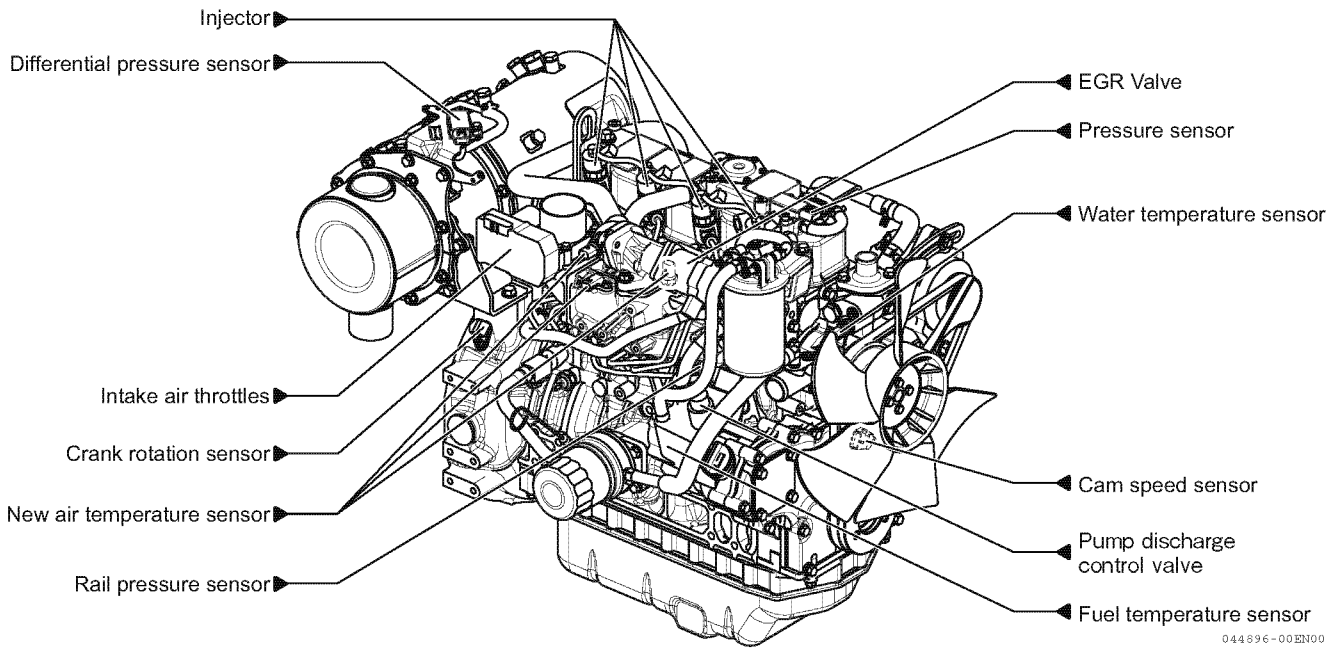

Figure 4-4

Supply Pump

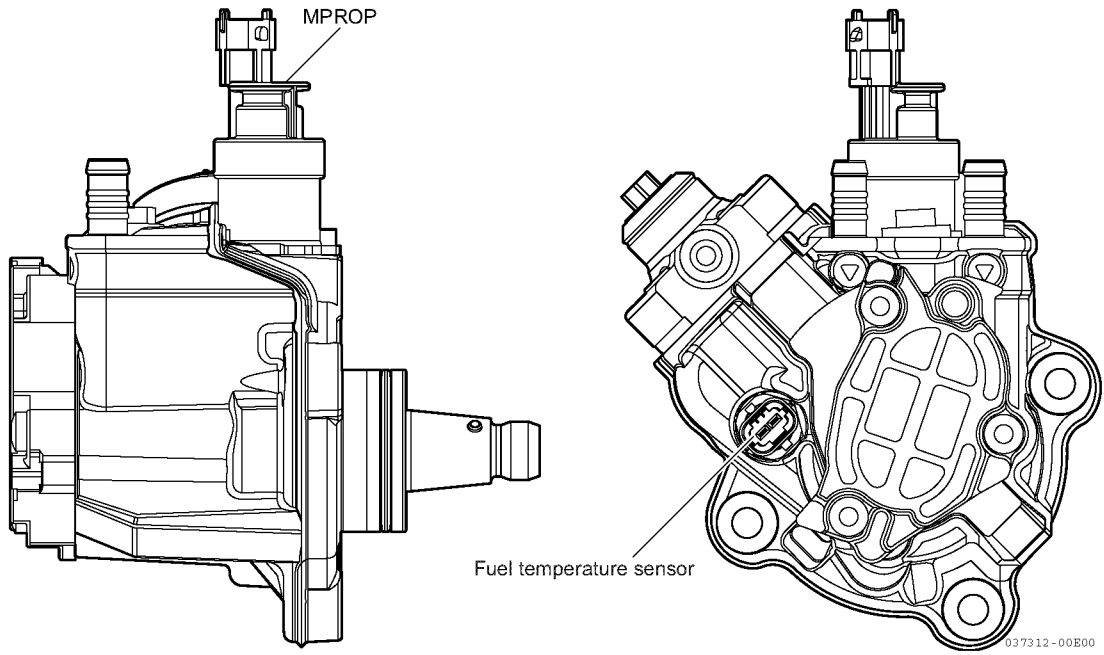

Figure 4-5

Rail Pressure Sensor

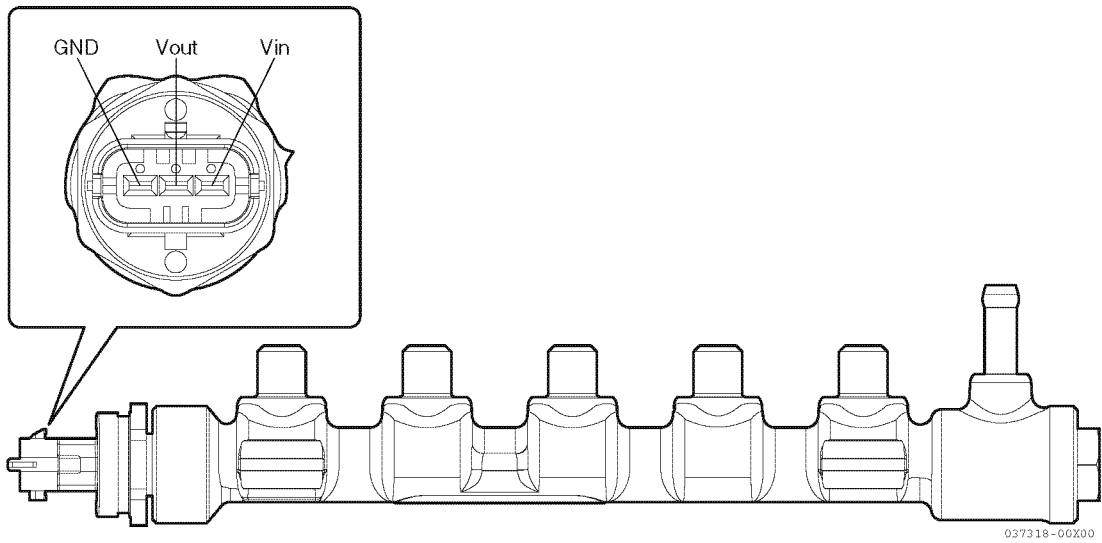

Figure 4-6

	3TNV88C, 3TNV86T	4TNV88C, 4TNV86CT, 4TNV98C, 4TNV98CT
Part No.	129A00-57000	129C00-57000

Crank Rotation Sensor

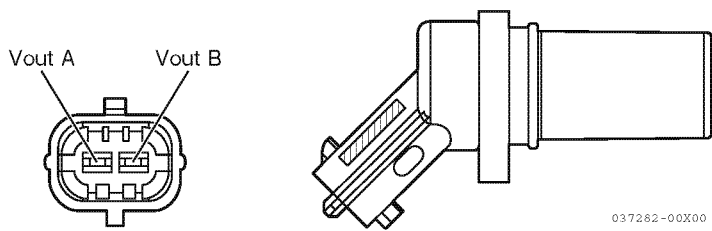

Figure 4-7

Part No.	129A00-21710
Sensor installation tightening torque	8 ± 2 N·m

Cam Speed Sensor

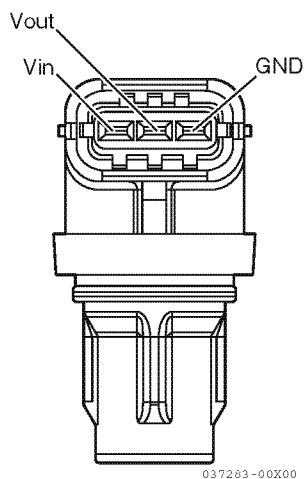

Figure 4-8

Part No.	129A00-14710
Sensor installation tightening torque	8 ± 0.5 N·m

Water Temperature Sensor

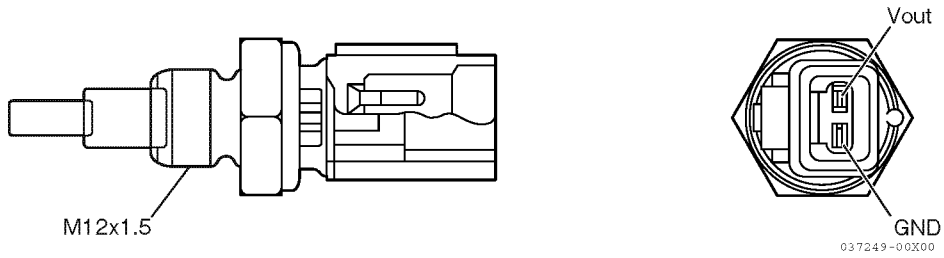

Figure 4-9

Part No.	129927-44900
Sensor installation tightening torque	22 ± 2 N·m

New Air Temperature Sensor

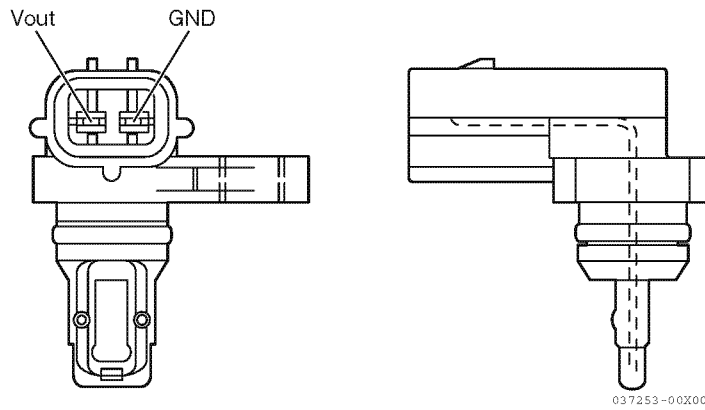
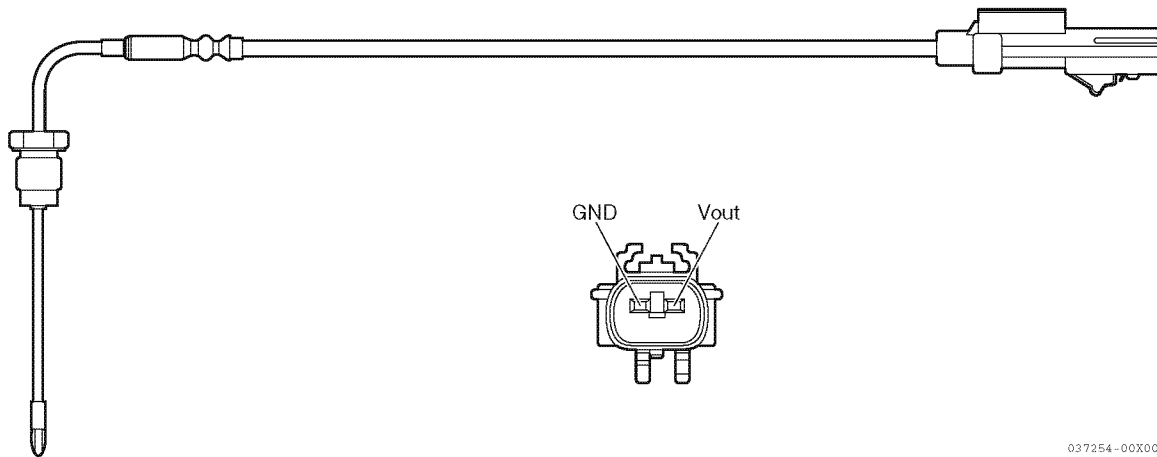

Figure 4-10

Part No.	129A00-12710
Sensor installation tightening torque	7 ± 1.4 N·m

Diesel Particulate Filter (DPF) Intermediate/Inlet, Exhaust Air Temperature Sensor



037254-00X00

Figure 4-11

	Exhaust air temperature sensor	DPF intermediate temperature sensor	DPF inlet temperature sensor
Part No.	129A00-13760 (Main)	129A00-13980	129A00-13990
Sensor installation tightening torque	25 - 40 N·m	25 - 40 N·m	25 - 40 N·m
Safety precaution	Do not lift the DPF by holding the sensor part.		

Diesel Particulate Filter (DPF) Differential Pressure Sensor

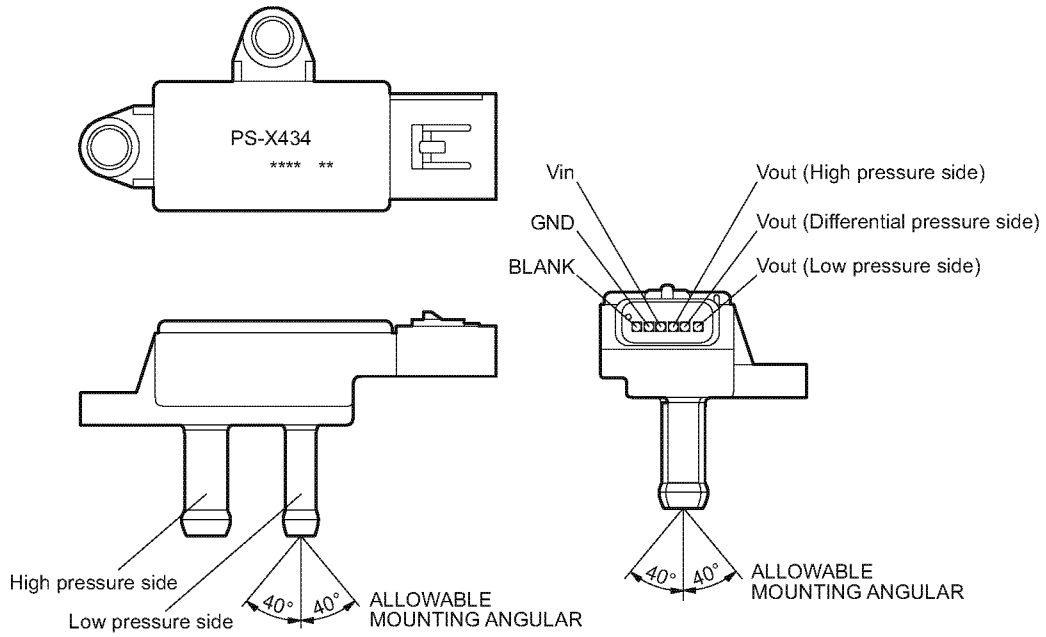

037255-00B00

Figure 4-12

Part No.	129A00-17700
Sensor installation tightening torque	7 ± 1.4 N·m
Safety precaution	<p>If you install a pipe to the DPF differential pressure sensor, do not install it as shown in the below figure. If water collects, the pressure cannot be detected.</p> <p>Differential pressure sensor pipe installation (example)</p>

037256-00B00

Intake/Exhaust Pressure Sensor

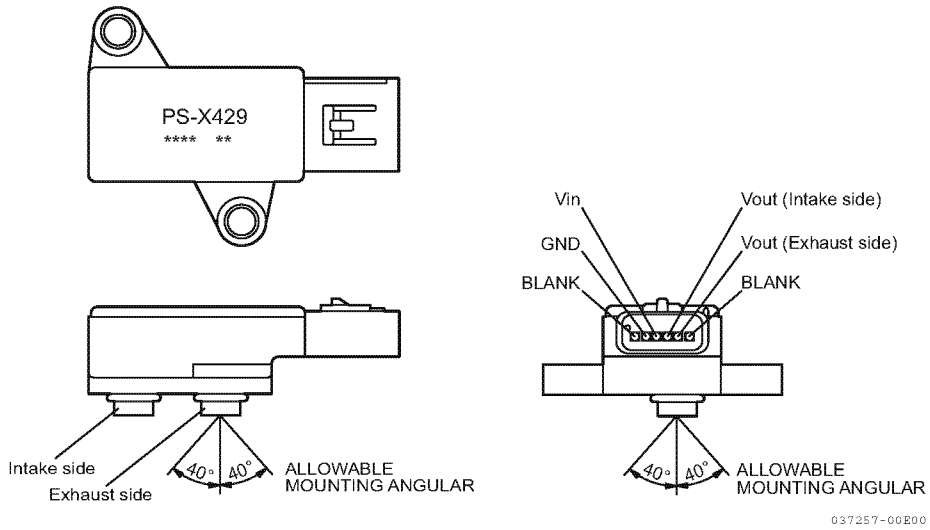

Figure 4-13

Part No.	129A00-12700
Sensor installation tightening torque	7 ± 1.4 N·m

Intake Air Temperature Sensor

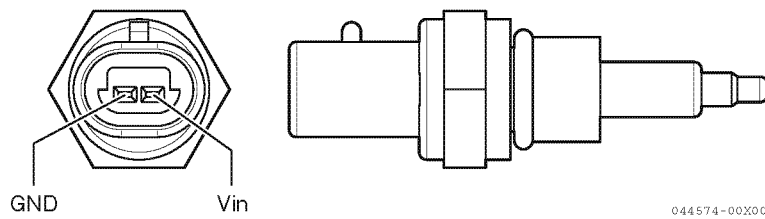

Figure 4-14

Part No.	129A00-12720
Sensor installation tightening torque	14 ± 3 N·m

EGR Gas Temperature Sensor

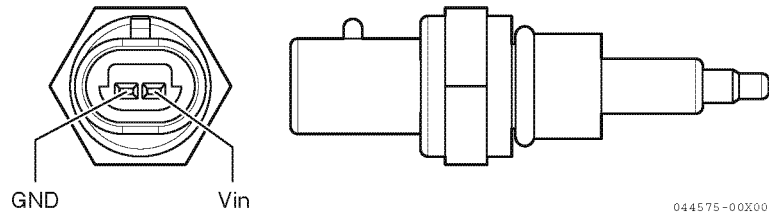

Figure 4-15

Part No.	129A00-13750
Sensor installation tightening torque	14 ± 3 N·m

EGR Valve

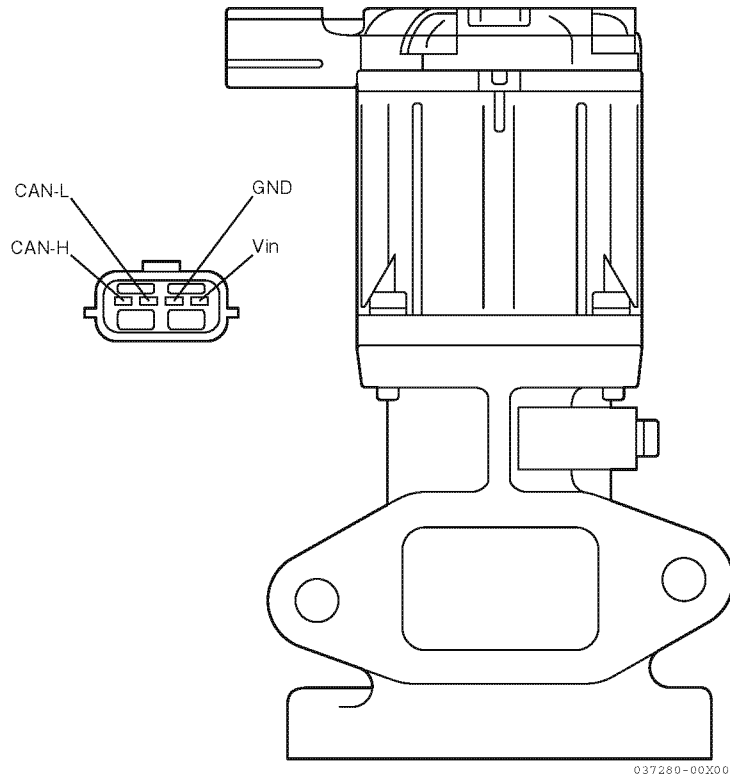

Figure 4-16

	3TNV88C, 3TNV86T	4TNV88C, 4TNV86CT	4TNV98C, 4TNV98CT
Part No.	129A00-13900	129C00-13900	129E00-13900

Intake Air Throttles

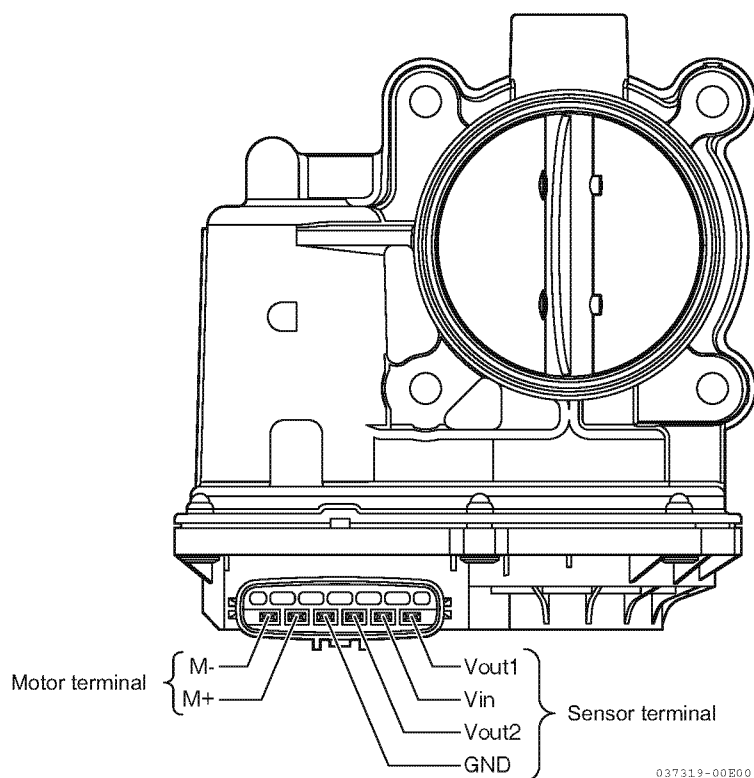

Figure 4-17

Part No.	129A00-12900
Sensor installation tightening torque	9.0 ± 1.8 N·m
Safety precaution	Be sure to read the precautions before handling the intake throttle.

Acceleration Sensor (YANMAR Standard)

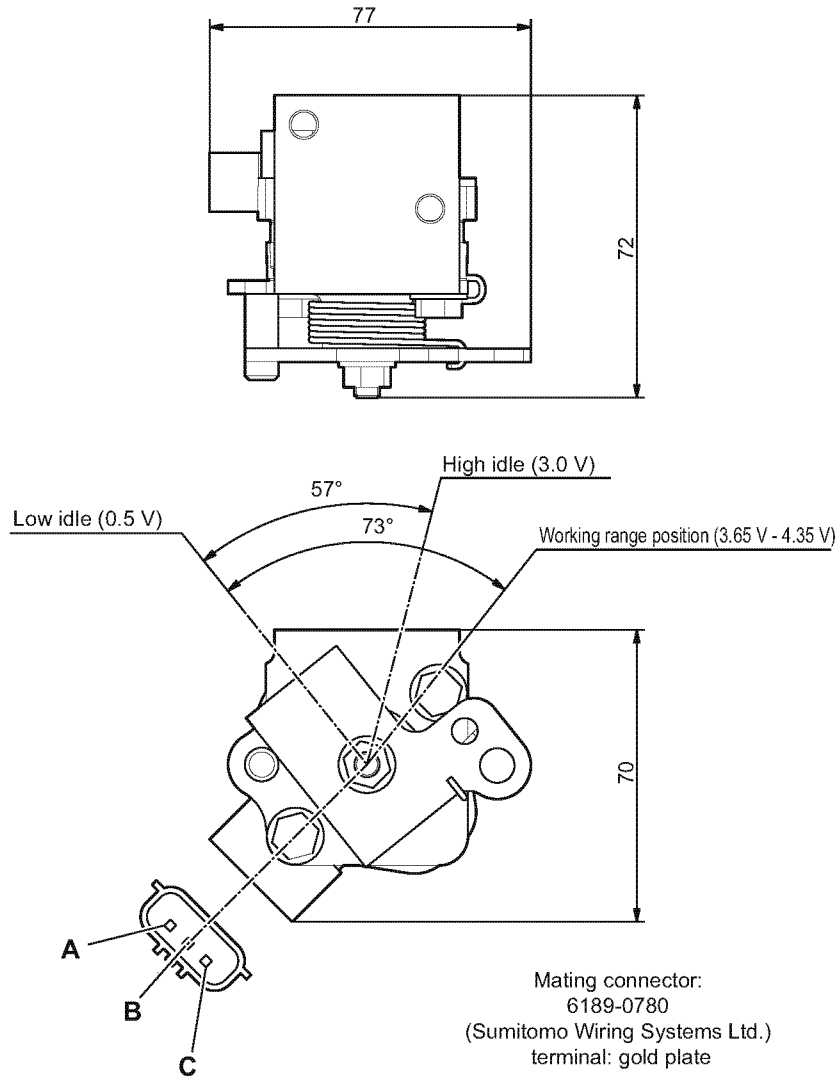

Figure 4-18

Terminal	Wire
A	GND GND-A
B	OUTPUT APS
C	INPUT AVCC

Rated voltage	DC 5 V ± 0.01 V
Part No.	129938-77800
Total resistance (sensor unit)	5 ± 1.5 kΩ

DIESEL FUEL

Diesel Fuel Specifications

Diesel fuel should comply with the following specifications. The table lists several worldwide specifications for diesel fuels.

Diesel fuel specification	Location
ASTM D975 No. 1D S15 No. 2D S15	USA
EN590:96	European Union
ISO 8217 DMX	International
BS 2869-A1 or A2	United Kingdom
JIS K2204 Grade No. 2	Japan
KSM-2610	Korea
GB252	China

■ Additional technical fuel requirements

- The fuel cetane number should be equal to 45 or higher.
- The sulfur content must be less than 15 ppm.
In general, using a high sulfur fuel may possible result in corrosion inside the cylinder. Especially in U.S.A. and Canada, Ultra Low Sulfur fuel must be used.
- Bio-diesel fuels. *See Bio-diesel fuels on page 4-22.*
- Never mix kerosene, used engine oil, or residual fuels with the diesel fuel.
- The water and sediment in the fuel should not exceed 0.05 % by volume.
- Keep the fuel tank and fuel-handling equipment clean at all times.
- Poor quality fuel can reduce engine performance and/or cause engine damage.
- Fuel additives are not recommended. Some fuel additives may cause poor engine performance. Consult your YANMAR representative for more information.
- The ash content must not exceed 0.01 % by volume.

- The carbon residue content must not exceed 0.35 % by volume. Less than 0.1 % is preferred.
- The total aromatics content should not exceed 35 % by volume. Less than 30 % is preferred.
- The PAH (Polycyclic Aromatic Hydrocarbons) content should be below 10 % by volume.
- The metal content of Na, Mg, Si, and Al should be equal to or lower than 1 mass ppm. (Test analysis method JPI-5S-44-95)
- Lubricity: The wear mark of WS1.4 should be Max. 0.018 in. (460 µm) at HFRR test.

■ Bio-diesel fuels

In Europe and in the United States, as well as some other countries, non-mineral oil based fuel resources such as RME (Rapeseed Methyl Ester) and SOME (Soybean Methyl Ester), collectively known as FAME (Fatty Acid Methyl Esters), are being used as extenders for mineral oil derived diesel fuels.

YANMAR approves the use of bio-diesel fuels that do not exceed a blend of 7 % (by volume) of FAME with 93 % (by volume) of approved mineral oil derived diesel fuel. Such bio-diesel fuels are known in the marketplace as B5 diesel fuels.

These B7 diesel fuels must meet certain requirements.

1. The bio-fuels must meet the minimum specifications for the country in which they are used.
 - In Europe, bio-diesel fuels must comply with the European Standard for both EN14214 and EN590 (for Oxidation stability).
 - In the United States, bio-diesel fuels must comply with the American Standard for both ASTM D-6751 and ASTM D-7467 (for Oxidation stability).
2. Bio-fuels should be purchased only from recognized and authorized diesel fuel suppliers.

Precautions and concerns regarding the use of bio-fuels:

1. Free methanol in FAME may result in corrosion of aluminum and zinc FIE components.
2. Free water in FAME may result in plugging of fuel filters and increased bacterial growth.
3. High viscosity at low temperatures may result in fuel delivery problems, supply pump seizures, and poor injection nozzle spray atomization.
4. FAME may have adverse effects on some elastomers (seal materials) and may result in fuel leakage and dilution of the engine lubricating oil.
5. Even bio-diesel fuels that comply with a suitable standard as delivered, will require additional care and attention to maintain the quality of the fuel in the equipment or other fuel tanks. It is important to maintain a supply of clean, fresh fuel. Regular flushing of the fuel system, and/or fuel storage containers, may be necessary.
6. Use bio diesel fuel within 2 months after filling it to the fuel tank, or within 3 months after its production at the manufacturer.
The use of bio-diesel fuels that do not comply with the standards as agreed to by the diesel engine manufacturers and the diesel fuel injection equipment manufacturers, or biodiesel fuels that have degraded as per the precautions and concerns above, may affect the warranty coverage of your engine. *YANMAR Limited Warranty on page 2-3.*

Filling The Fuel Tank**⚠ DANGER****Fire and Explosion Hazard!**

- Diesel fuel is flammable and explosive under certain conditions.

- Only fill the fuel tank with diesel fuel. Filling the fuel tank with gasoline may result in a fire and will damage the engine.
- Never refuel with the engine running.
- Wipe up all spills immediately.
- Keep sparks, open flames or any other form of ignition (match, cigarette, static electric source) well away when refueling.
- Never overfill the fuel tank.
- Fill the fuel tank. Store any containers containing fuel in a well-ventilated area, away from any combustibles or sources of ignition.
- Be sure to place the diesel fuel container on the ground when transferring the diesel fuel from the pump to the container. Hold the hose nozzle firmly against the side of the container while filling it. This prevents static electricity buildup which could cause sparks and ignite fuel vapors.
- Never place diesel fuel or other flammable material such as oil, hay or dried grass close to the engine during engine operation or shortly after shutdown.
- Before you operate the engine, check for fuel leaks. Replace rubberized fuel hoses every two years or every 2000 hours of engine operation, whichever comes first, even if the engine has been out of service. Rubberized fuel lines tend to dry out and become brittle after two years or 2000 hours of engine operation, whichever comes first.
- Failure to comply will result in death or serious injury.

NOTICE

- Only use diesel fuels recommended by YANMAR for the best engine performance, to prevent engine damage and to comply with EPA/ARB warranty requirements.
- Only use clean diesel fuel.
- Never remove the primary strainer (if equipped) from the fuel tank filler port. If removed, dirt and debris could get into the fuel system causing it to clog.

Note that a typical fuel tank is shown. The fuel tank on your equipment may be different.

1. Clean the area around the fuel cap (**Figure 4-19, (1)**).
2. Remove the fuel cap from the fuel tank (**Figure 4-19, (2)**).
3. Observe the fuel level sight gauge (**Figure 4-19, (3)**) and stop fueling when the gauge shows the fuel tank is full. Never overfill the fuel tank.
4. Replace the fuel cap (**Figure 4-19, (1)**) and hand tighten. Over-tightening the fuel cap will damage it.

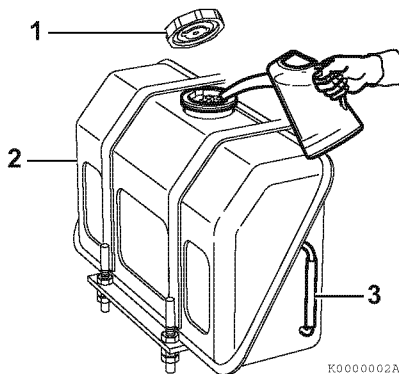

Figure 4-19

Priming the Fuel System

The fuel system needs to be primed under certain conditions:

- Before starting the engine for the first time.
- After running out of fuel and fuel has been added to the fuel tank.
- After fuel system maintenance such as changing the fuel filter and draining the fuel filter/water separator, or replacing a fuel system component.

To prime the fuel system:

1. Turn the key to the ON position for 10 - 15 seconds. This will allow the electric fuel pump to prime the fuel system.
2. Never use the starter motor to crank the engine in order to prime the fuel system. This may cause the starter motor to overheat and damage the coils, pinion and/or ring gear.

NOTICE

Check the fuel level gauge in the fuel tank daily and ensure that the engine does not run out of fuel. Seizure to the supply pump may occur.

ENGINE OIL

NOTICE

- Only use the engine oil specified. Other engine oils may affect warranty coverage, cause internal engine components to seize and/or shorten engine life.
- Prevent dirt and debris from contaminating the engine oil. Carefully clean the oil cap/dipstick and the surrounding area before you remove the cap.
- Never mix different types of engine oil. This may adversely affect the lubricating properties of the engine oil.
- Never overfill. Overfilling may result in white exhaust smoke, engine overspeed or internal damage.

Engine Oil Specifications

Use an engine oil that meets or exceeds the following guidelines and classifications:

■ Service categories

- API service categories CJ-4
- ACEA service categories E6
- JASO service category DH-2

■ Definitions

- API classification (American Petroleum Institute)
- ACEA classification (Association des Constructeurs Européens d'Automobiles)
- JASO (Japanese Automobile Standards Organization)

Note:

- Be sure the engine oil, engine oil storage containers, and engine oil filling equipment are free of sediment and water.
- Change the engine oil after the first 50 hours of operation and then every 250 hours thereafter.
- Select the oil viscosity based on the ambient temperature where the engine is being operated. See the SAE service grade viscosity chart (Figure 4-20).
- YANMAR does not recommend the use of engine oil "additives."
- Never use synthetic oil.

■ Additional technical engine oil requirements:

The engine oil must be changed when the Total Base Number (TBN) has been reduced to 1.0 mgKOH/g test method; JIS K-201-5.2-2 (HCl), ASTM D4739 (HCl).

Engine Oil Viscosity

Select the appropriate engine oil viscosity based on the ambient temperature and use the SAE service grade viscosity chart in Figure 4-20.

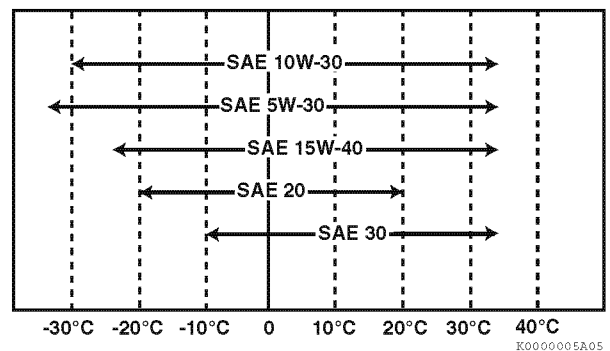

Figure 4-20

Checking Engine Oil

1. Make sure the engine is level.
2. Remove the dipstick (**Figure 4-21, (1)**) and wipe it with clean cloth.
3. Fully reinsert the dipstick.
4. Remove the dipstick. The oil level should be between the upper (**Figure 4-21, (2)**) and lower (**Figure 4-21, (3)**) lines on the dipstick.
5. Fully reinsert the dipstick.

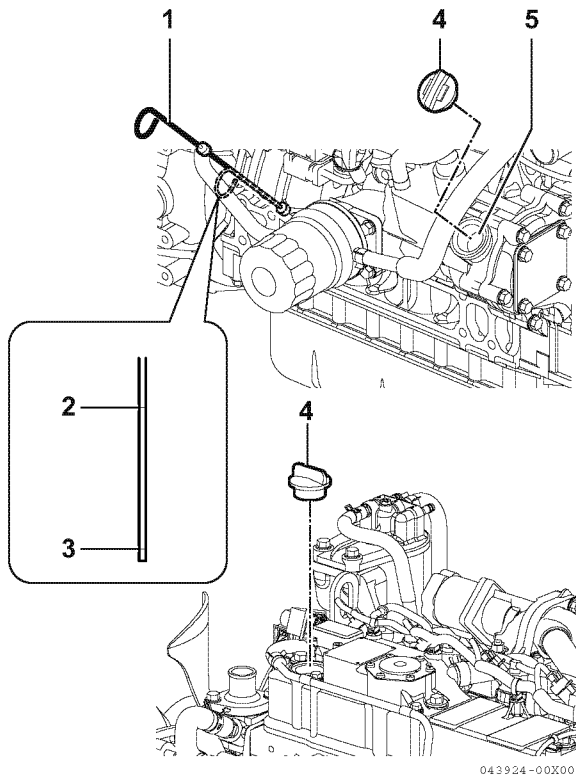

Figure 4-21

Adding Engine Oil

1. Make sure the engine is level.
2. Remove the oil cap (**Figure 4-21, (4)**).
3. Add the indicated amount of engine oil at the top or the side engine oil filler port (**Figure 4-21, (5)**).
4. Wait three minutes and check the oil level.
5. Add more oil if necessary.
6. Reinstall the oil cap (**Figure 4-21, (4)**) and hand-tighten. Over-tightening may damage the cap.

Engine Oil Capacity (Typical)

Note: These are the engine oil capacities associated with a "deep standard" oil pan. The oil capacity will vary dependant upon which optional oil pan is used. Refer to the operation manual provided by the driven machine manufacturer for the actual engine oil capacity of your machine.

The following are the engine oil capacities for various YANMAR TNV engines.

Engine model	Dipstick upper limit/lower limit
3TNV88C, 3TNV86CT	7.1/4.1 qt (6.7/3.9 ℓ)
4TNV88C, 4TNV86CT	7.8/4.2 qt (7.4/4.0 ℓ)
4TNV98C, 4TNV98CT	11.1/6.3 qt (10.5/6.0 ℓ)

ENGINE COOLANT

⚠ DANGER**Scald Hazard!**

- Never remove the radiator cap if the engine is hot. Steam and hot engine coolant will spurt out and seriously burn you. Allow the engine to cool down before you attempt to remove the radiator cap.
- Tighten the radiator cap securely after you check the radiator. Steam can spurt out during engine operation if the cap is loose.
- Always check the level of the engine coolant by observing the reserve tank.
- Failure to comply will result in death or serious injury.

⚠ WARNING**Burn Hazard!**

- Wait until the engine cools before you drain the engine coolant. Hot engine coolant may splash and burn you.
- Failure to comply could result in death or serious injury.

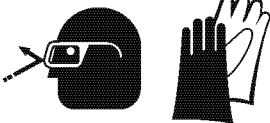
⚠ CAUTION**Coolant Hazard!**

- Wear eye protection and rubber gloves when you handle long life or extended life engine coolant. If contact with the eyes or skin should occur, flush eyes and wash immediately with clean water.
- Failure to comply may result in minor or moderate injury.

NOTICE

- Only use the engine coolant specified. Other engine coolants may affect warranty coverage, cause an internal buildup of rust and scale and/or shorten engine life.
- Prevent dirt and debris from contaminating the engine coolant. Carefully clean the radiator cap and the surrounding area before you remove the cap.
- Never mix different types of engine coolants. This may adversely affect the properties of the engine coolant.

Engine Coolant Specifications

Use a Long Life Coolant (LLC) or an Extended Life Coolant (ELC) that meets or exceeds the following guidelines and specifications:

■ Additional technical coolant specifications:

- ASTM D6210, D4985 (US)
- JIS K-2234 (Japan)
- SAE J814C, J1941, J1034 or J2036 (International)

■ Alternative engine coolant

If an Extended or Long Life Coolant is not available, alternatively, you may use an ethylene glycol or propylene glycol based conventional coolant (green).

Note:

- Always use a mix of coolant and water. Never use water only.
- Mix the coolant and water per the mixing instructions on the coolant container.
- Water quality is important to coolant performance. YANMAR recommends that soft, distilled, or demineralized water be used to mix with coolants.
- Never mix extended or long life coolants and conventional (green) coolants.
- Never mix different types and/or colors of extended life coolants.
- Replace the coolant every 1000 engine hours or once a year.

Filling Radiator with Engine Coolant

Fill the radiator and reserve tank as follows. This procedure is for filling the radiator for the first time or refilling it after it is flushed. Note that a typical radiator is illustrated (**Figure 4-22**).

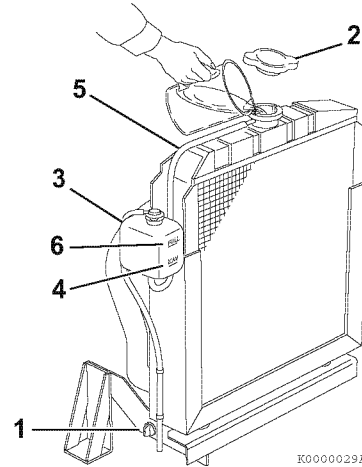

Figure 4-22

1. Check to be sure the radiator drain plug is installed and tightened or the drain cock (**Figure 4-22, (1)**) is closed. Also make sure the coolant drain plug (**Figure 4-23, (1)**) installed on the hose joint is closed.

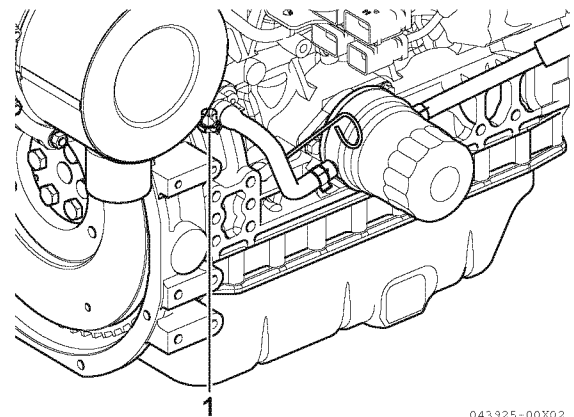

Figure 4-23

2. Remove the radiator cap (**Figure 4-22, (2)**) by turning it counter-clockwise about 1/3 of a turn.

3. Pour the engine coolant slowly into the radiator until it is even with the lip of the engine coolant filler port. Make sure that air bubbles do not develop as you fill the radiator.
4. Reinstall the radiator cap (**Figure 4-22, (2)**). Align the tabs on the back side of the radiator cap with the notches on the engine coolant filler port. Press down and turn the cap clockwise about 1/3 of a turn.
5. Remove the cap on the reserve tank (**Figure 4-22, (3)**), and fill it to the LOW (COLD) mark (**Figure 4-22, (4)**) with engine coolant. Reinstall the cap.
6. Check the hose (**Figure 4-22, (5)**) that connects the reserve tank (**Figure 4-22, (3)**) to the radiator. Be sure it is securely connected and there are no cracks or damage. If the hose is damaged, the engine coolant will leak out instead of going into the reserve tank.
7. Run the engine until it is at operating temperature. Check the level of engine coolant in the reserve tank. When the engine is running and the engine coolant is at normal temperature, the coolant level in the tank should be at the FULL (HOT) mark (**Figure 4-22, (6)**). If the engine coolant is not at the FULL (HOT) mark (**Figure 4-22, (6)**), add additional engine coolant to the reserve tank to bring the level to the FULL (HOT) mark.

Engine Coolant Capacity (Typical)

Note: The capacities listed are for the engine only without a radiator. Refer to the operation manual provided by the driven machine manufacturer for the actual engine coolant capacity on your machine.

The following are the engine coolant capacities for various YANMAR TNV engines.

Engine model	Engine coolant capacity
3TNV88C, 3TNV86CT	2.1 qt (2.0 ℓ)
4TNV88C, 4TNV86CT	2.9 qt (2.7 ℓ)
4TNV98C, 4TNV98CT	4.4 qt (4.2 ℓ)

SPECIFICATIONS

Description of Model Number

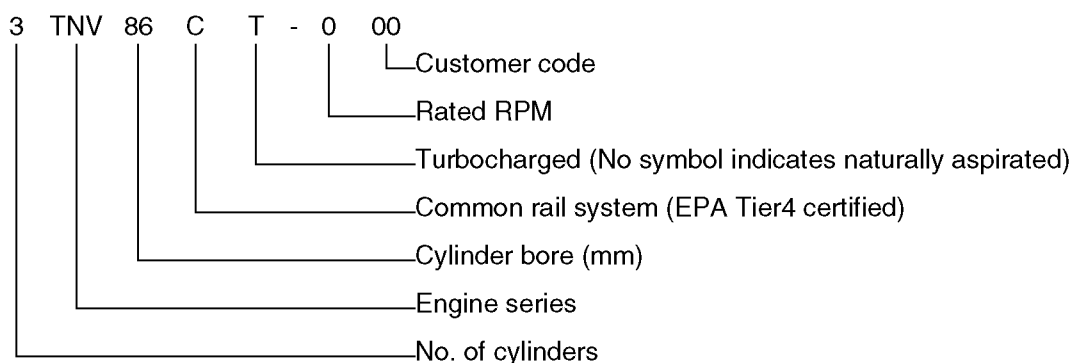

Engine General Specifications

Type	Vertical in-line, water cooled, 4-cycle diesel engine
Fuel injection system	Common rail system
Starting system	Electric starting
Cooling system	Radiator
Lubricating system	Forced lubrication with trochoid pump
PTO position	Flywheel end
Direction of rotation	Counterclockwise viewed from flywheel end

Note:

- The information described in *Principal Engine Specifications* is for a “standard” engine. To obtain the information for the engine installed in your driven machine, please refer to the manual provided by the driven machine manufacturer.
- Engine rating conditions are as follows (SAE J1349, ISO 3046/1):
 - Atmospheric condition: Room temperature 77 °F (25 °C), atmospheric pressure 29.53 in. Hg (100 kPa, 750 mm Hg), relative humidity 30 %
 - Fuel temperature at fuel injector pump inlet: 104 °F (40 °C)
 - Fuel feeding pressure: 20 ± 10 kPa (net) after engine break-in has been performed with the cooling fan, air cleaner and muffler installed to the engine.
 - With cooling fan, air cleaner, muffler: YANMAR standard
 - After the engine break-in period. Output allowable deviation: ± 3 %
 - 1 PS = 0.7355 kW
 - 1 hp SAE (Society of Automotive Engineers) = 0.7457 kW

PRINCIPAL ENGINE SPECIFICATIONS

3TNV88C

Engine model	3TNV88C
Version	VM
Type	Vertical in-line diesel engine (Common rail system)
Combustion system	Direct injection
Aspiration	Naturally aspiration
No. of cylinders	3
Bore x stroke	88 x 90 mm
Displacement	1.642 ℓ
Max. rated output (Gross)	3000 min ⁻¹
	27.5 kW
	37.4 PS
High idling	3150 ± 25 min ⁻¹
Engine weight (Dry)	188 kg
PTO position	Flywheel end
Direction of rotation	Counterclockwise viewed from flywheel end
Cooling system	Liquid-cooled with radiator
Lubricating system	Forced lubrication with trochoid pump
Normal oil pressure at rated engine speed	0.34 - 0.54 MPa
Normal oil pressure at low idle speed	0.06 MPa
Starting system	Electric starting (Starter motor: DC 12 V - 1.7 kW)
	Alternator (12 V - 55 A)
	Recommended battery capacity: 12 V 413CCA
Dimensions (L x W x H)	Depend on DPF layout
Engine oil pan capacity	6.7/3.9 ℓ Dipstick upper limit/lower limit)
Engine coolant capacity	2.0 ℓ (Engine only)
Standard cooling fan	ø335 pusher
Crank V-pulley dia./ fan V-pulley dia.	ø110/ø110 mm
Top clearance	0.73 ± 0.06 mm

3TNV86CT

Engine model	3TNV86CT
Version	VM
Type	Vertical in-line diesel engine (Common rail system)
Combustion system	Direct injection
Aspiration	Turbocharged
No. of cylinders	3
Bore x stroke	86 x 90 mm
Displacement	1.568 ℓ
Max. rated output (Gross)	3000 min ⁻¹
	32.4 kW
	44.1 PS
High idling	3150 ± 25 min ⁻¹
Engine weight (Dry)	200 kg
PTO position	Flywheel end
Direction of rotation	Counterclockwise viewed from flywheel end
Cooling system	Liquid-cooled with radiator
Lubricating system	Forced lubrication with trochoid pump
Normal oil pressure at rated engine speed	0.34 - 0.54 MPa
Normal oil pressure at low idle speed	0.06 MPa
Starting system	Electric starting (Starter motor: DC 12 V - 1.7 kW)
	Alternator (12 V - 55 A)
	Recommended battery capacity: 12 V 413CCA
Dimensions (L x W x H)	Depend on DPF layout
Engine oil pan capacity	6.7/3.9 ℓ Dipstick upper limit/lower limit)
Engine coolant capacity	2.0 ℓ (Engine only)
Standard cooling fan	ø350 pusher
Crank V-pulley dia./ fan V-pulley dia.	ø110/ø110 mm
Top clearance	0.73 ± 0.06 mm

4TNV88C

Engine model	4TNV88C
Version	VM
Type	Vertical in-line diesel engine (Common rail system)
Combustion system	Direct injection
Aspiration	Naturally aspiration
No. of cylinders	4
Bore x stroke	88 x 90 mm
Displacement	2.189 ℓ
Max. rated output (Gross)	3000 min ⁻¹
	35.5 kW
	48.3 PS
High idling	3150 ± 25 min ⁻¹
Engine weight (Dry)	220 kg
PTO position	Flywheel end
Direction of rotation	Counterclockwise viewed from flywheel end
Cooling system	Liquid-cooled with radiator
Lubricating system	Forced lubrication with trochoid pump
Normal oil pressure at rated engine speed	0.32 - 0.47 MPa
Normal oil pressure at low idle speed	0.06 MPa
Starting system	Electric starting (Starter motor: DC 12 V - 1.7 kW)
	Alternator (12 V - 55 A)
	Recommended battery capacity: 12 V 622CCA
Dimensions (L x W x H)	Depend on DPF layout
Engine oil pan capacity	7.4/4.0 ℓ Dipstick upper limit/lower limit)
Engine coolant capacity	2.7 ℓ (Engine only)
Standard cooling fan	ø370 pusher
Crank V-pulley dia./ fan V-pulley dia.	ø110/ø110 mm
Top clearance	0.73 ± 0.06 mm

4TNV86CT

Engine model	4TNV86CT
Version	VM
Type	Vertical in-line diesel engine (Common rail system)
Combustion system	Direct injection
Aspiration	Turbocharged
No. of cylinders	4
Bore x stroke	86 x 90 mm
Displacement	2.090 ℓ
Max. rated output (Gross)	3000 min ⁻¹
	44.0 kW
	59.8 PS
High idling	3150 ± 25 min ⁻¹
Engine weight (Dry)	225 kg
PTO position	Flywheel end
Direction of rotation	Counterclockwise viewed from flywheel end
Cooling system	Liquid-cooled with radiator
Lubricating system	Forced lubrication with trochoid pump
Normal oil pressure at rated engine speed	0.36 - 0.51 MPa
Normal oil pressure at low idle speed	0.06 MPa
Starting system	Electric starting (Starter motor: DC 12 V - 1.7 kW)
	Alternator (12 V - 55 A)
	Recommended battery capacity: 12 V 622CCA
Dimensions (L x W x H)	Depend on DPF layout
Engine oil pan capacity	7.4/4.0 ℓ Dipstick upper limit/lower limit)
Engine coolant capacity	2.7 ℓ (Engine only)
Standard cooling fan	ø370 pusher
Crank V-pulley dia./ fan V-pulley dia.	ø110/ø110 mm
Top clearance	0.73 ± 0.06 mm

4TNV98C

Engine model	4TNV98C
Version	VM
Type	Vertical in-line diesel engine (Common rail system)
Combustion system	Direct injection
Aspiration	Naturally aspiration
No. of cylinders	4
Bore x stroke	98 x 110 mm
Displacement	3.319 ℓ
Max. rated output (Gross)	2500 min ⁻¹
	51.7 kW
	70.3 PS
High idling	2650 ± 25 min ⁻¹
Engine weight (Dry)	280 kg
PTO position	Flywheel end
Direction of rotation	Counterclockwise viewed from flywheel end
Cooling system	Liquid-cooled with radiator
Lubricating system	Forced lubrication with trochoid pump
Normal oil pressure at rated engine speed	0.29 - 0.39 MPa
Normal oil pressure at low idle speed	0.06 MPa
Starting system	Electric starting (Starter motor: DC 12 V - 3.0 kW)
	Alternator (DC12 V - 55 A)
	Recommended battery capacity: 12 V 799CCA
Dimensions (L x W x H)	Depend on DPF layout
Engine oil pan capacity	10.5/6.0 ℓ Dipstick upper limit/lower limit)
Engine coolant capacity	4.2 ℓ (Engine only)
Standard cooling fan	ø430 pusher
Crank V-pulley dia./ fan V-pulley dia.	ø130/ø130 mm
Top clearance	0.793 ± 0.063 mm

4TNV98CT

Engine model	4TNV98CT
Version	VM
Type	Vertical in-line diesel engine (Common rail system)
Combustion system	Direct injection
Aspiration	Turbocharged
No. of cylinders	4
Bore x stroke	94 x 110 mm
Displacement	3.053 ℓ
Max. rated output (Gross)	2500 min ⁻¹
	53.7 kW
	73.0 PS
High idling	2650 ± 25 min ⁻¹
Engine weight (Dry)	291 kg
PTO position	Flywheel end
Direction of rotation	Counterclockwise viewed from flywheel end
Cooling system	Liquid-cooled with radiator
Lubricating system	Forced lubrication with trochoid pump
Normal oil pressure at rated engine speed	0.29 - 0.39 MPa
Normal oil pressure at low idle speed	0.06 MPa
Starting system	Electric starting (Starter motor: DC 12 V - 3.0 kW)
	Alternator (DC12 V - 55 A)
	Recommended battery capacity: 12 V 799CCA
Dimensions (L x W x H)	Depend on DPF layout
Engine oil pan capacity	10.5/6.0 ℓ Dipstick upper limit/lower limit)
Engine coolant capacity	4.2 ℓ (Engine only)
Standard cooling fan	ø430 pusher
Crank V-pulley dia./ fan V-pulley dia.	ø130/ø130 mm
Top clearance	0.793 ± 0.071 mm

Set Output Listed by Rotation

Model	Displacement	Gross output (kW)									
		2000	2100	2200	2300	2400	2500	2600	2700	2800	3000
3TNV88C	1.642	–	–	–	–	21.8	22.8	23.7	24.6	25.5	27.5
3TNV86CT	1.568	–	–	–	–	–	27.4	28.5	–	31.0	32.4
4TNV88C	2.189	24.2	25.4	26.7	27.9	29.1	30.5	31.7	33.0	34.3	35.5
4TNV86CT	2.091	–	–	–	–	35.5	36.6	37.9	39.5	41.1	44.0
4TNV98C	3.318	42.4	44.3	46.2	48.1	49.9	51.7	–	–	–	–
4TNV98CT	3.318	51.6	53.7	53.7	53.7	53.7	53.7	–	–	–	–

ENGINE SERVICE STANDARDS

Inspection item		Standard	Limit	Reference page
Intake/exhaust valve clearance	All models	0.006 - 0.010 in. (0.15 - 0.25 mm)	–	See <i>Measuring and Adjusting Valve Clearance</i> on page 6-40
Compression pressure at 250 min ⁻¹ (rpm)	3TNV88C, 4TNV88C	455 - 485 PSI (3.14 - 3.34 MPa; 32 - 34 kgf/cm ²)	355 - 385 PSI (2.45 - 2.65 MPa; 25 - 27 kgf/cm ²)	–
	3TNV86CT, 4TNV86CT	411 - 441 PSI (2.84 - 3.04 MPa; 29 - 31 kgf/cm ²)	340 - 370 PSI (2.35 - 2.55 MPa; 24 - 26 kgf/cm ²)	
	4TNV98C, 4TNV98CT	483 - 513 PSI (3.33 - 3.53 MPa; 34 - 36 kgf/cm ²)	384 - 414 PSI (2.65 - 2.85 MPa; 27 - 29 kgf/cm ²)	
Deviation between cylinders	All models	29 - 43 PSI (0.2 - 0.3 MPa; 2 - 3 kgf/cm ²)	–	–
Oil pressure switch operating pressure		5.8 - 8.8 PSI (0.04 - 0.06 MPa; 0.4 - 0.6 kgf/cm ²)	–	–
Thermostat		Valve opening temperature	Full opening lift temperature	See <i>Thermostat</i> on page 8-9
	All models	157 °F - 163 °F (70 °C - 73 °C)	0.32 in. (8 mm) or above 185 °F (85 °C)	
	All models option	176 °F - 183 °F (80 °C - 84 °C)	0.39 in. (10 mm) or above 203 °F (95 °C)	
Coolant temperature switch		225 °F - 235 °F (107 °C - 113 °C)	–	See <i>Temperature switch</i> on page 8-8

TIGHTENING TORQUES FOR STANDARD BOLTS AND NUTS

Use the correct amount of torque when you tighten the fasteners on the machine. Applying excessive torque may damage the fastener or component and not enough torque may cause a leak or component failure.

NOTICE

The tightening torque in the *Standard Torque Chart* (see *General Service Information* section) should be applied only to the bolts with a “7” head. (JIS strength classification: 7T)

- Apply 60 % torque to bolts that are not listed.
- Apply 80 % torque when tightened to aluminum alloy.



Item	Nominal thread diameter × pitch	Tightening torque	Remarks
Hexagon bolt (7T) and nut	M6 × 1.0 mm	7 - 9 ft-lb (87 -104 in.-lb, 9.8 -11.8 N·m, 1.0 -1.2 kgf·m)	Use 80 % of the value at left when the tightening part is aluminum. Use 60 % of the value at left for 4T bolts and lock nuts.
	M8 × 1.25 mm	17 - 21 ft-lb (200 - 251 in.-lb, 22.6 - 28.4 N·m, 2.3 - 2.9 kgf·m)	
	M10 × 1.5 mm	33 - 40 ft-lb (44.1 - 53.9 N·m, 4.5 - 5.5 kgf·m)	
	M12 × 1.75 mm	58 - 72 ft-lb (78.4 - 98.0 N·m, 8.0 - 10 kgf·m)	
	M14 × 1.5 mm	94 - 108 ft-lb (127.5 - 147.1 N·m, 13 - 15 kgf·m)	
	M16 × 1.5 mm	159 - 174 ft-lb (215.7- 235.4 N·m, 22 - 24 kgf·m)	
PT plug	1/8	7 ft-lb (87 in.-lb, 9.8 N·m, 1.0 kgf·m)	-
	1/4	14 ft-lb (173 in.-lb, 19.6 N·m, 2.0 kgf·m)	
	3/8	22 ft-lb (29.4 N·m, 3.0 kgf·m)	
	1/2	43 ft-lb (58.8 N·m, 6.0 kgf·m)	

GENERAL SERVICE INFORMATION Tightening Torques for Standard Bolts and Nuts

Item	Nominal thread diameter × pitch	Tightening torque	Remarks
Pipe joint bolt	M8	9 - 12 ft-lb (112 - 148 in.-lb, 12.7 - 16.7 N·m, 1.3 - 1.7 kgf·m)	-
	M10	14 - 19 ft-lb (173 - 225 in.-lb, 19.6 - 18.734 N·m, 2.0 - 3.5 kgf·m)	
	M12	18 - 25 ft-lb (24.5 - 34.3 N·m, 2.5 - 3.5 kgf·m)	
	M14	29 - 36 ft-lb (39.2 - 49.0 N·m, 4.0 - 5.0 kgf·m)	
	M16	36 - 43 ft-lb (49.0 - 58.8 N·m, 5.0 - 6.0 kgf·m)	

Note: Torque values shown in this manual are for clean, non-lubricated fasteners unless otherwise specified.

ABBREVIATIONS AND SYMBOLS

■ Abbreviations

A	ampere
AC	alternating current
ACEA	Association des Constructeurs Européens d'Automobilies
Ah	ampere-hour
API	American Petroleum Institute
ARB	Air Resources Board
ATDC	after top dead center
BDC	bottom dead center
BTDC	before top dead center
°C	degree Celsius
CARB	California Air Resources Board
CCA	cold cranking amp
cfm	cubic feet per minute
cm	centimeter
cm³	cubic centimeter
cm³/min	cubic centimeter per minute
cu in.	cubic inch
D	diameter
DC	direct current
DI	direct injection
DVA	direct volt adapter
EPA	Environmental Protection Agency
ESG	electronic speed governor
°F	degree Fahrenheit
fl oz	fluid ounce (U.S.)
fl oz/min	fluid ounce (U.S.) per minute
ft	foot
ft-lb	foot pound
ft-lbf/min	foot pound force per minute
g	gram
gal	gallon (U.S.)
gal/hr	gallon (U.S.) per hour
gal/min	gallon (U.S.) per minute
GL	gear lubricant
hp	horsepower (U.S.)
hr	hour
I.D.	inside diameter
ID	identification
IDI	indirect injection
in.	inch
in.Aq	inches Aqueous (water)
in.Hg	inches Mercury
in.-lb	inch pound
j	joule
JASO	Japanese Automobile Standards Organization

k	kelvin
kg	kilogram
kgf/cm²	kilogram force per square centimeter
kgf/m	kilogram force per meter
km	kilometers
kPa	kilopascal
kW	kilowatt
L	liter
L/hr	liter per hour
lb	pound
lbf	pound force
m	meter
mL	milliliter
mm	millimeter
mmAq	millimeter Aqueous (water)
MPa	megapascal
mV	millivolt
N	newton
N·m	newton meter
No.	number
O.D.	outside diameter
oz	ounce
Pa	pascal
PS	horsepower (metric)
PSI	pound per square inch
qt	quart (U.S.)
R	radius
rpm	revolutions per minute
SAE	Society of Automotive Engineers
sec.	second
t	short ton 2000 lb
TBN	total base number
TDC	top dead center
V	volt
VAC	volt alternating current
VDC	volt direct current
W	watt

■ Symbols

°	degree
+	plus
-	minus
±	plus or minus
Ω	ohm
μ	micro
%	percent

UNIT CONVERSIONS

■ Unit prefixes

Prefix	Symbol	Power
mega	M	× 1,000,000
kilo	k	× 1,000
centi	c	× 0.01
milli	m	× 0.001
micro	μ	× 0.000001

■ Units of length

mile	×	1.6090	= km
ft	×	0.3050	= m
in.	×	2.5400	= cm
in.	×	25.4000	= mm
km	×	0.6210	= mile
m	×	3.2810	= ft
cm	×	0.3940	= in.
mm	×	0.0394	= in.

■ Units of volume

gal (U.S.)	×	3.78540	= ℓ
qt (U.S.)	×	0.94635	= ℓ
cu in.	×	0.01639	= ℓ
cu in.	×	16.38700	= ml
fl oz (U.S.)	×	0.02957	= ℓ
fl oz (U.S.)	×	29.57000	= ml
cm ³	×	1.00000	= ml
cm ³	×	0.03382	= fl oz (U.S.)

■ Units of mass

lb	×	0.45360	= kg
oz	×	28.35000	= g
kg	×	2.20500	= lb
g	×	0.03527	= oz

■ Units of force

lbf	×	4.4480	= N
lbf	×	0.4536	= kgf
N	×	0.2248	= lbf
N	×	0.1020	= kgf
kgf	×	2.2050	= lbf
kgf	×	9.8070	= N

■ Units of torque

ft-lb	×	1.3558	= N·m
ft-lb	×	0.1383	= kgf/m
in.-lb	×	0.1130	= N·m
in.-lb	×	0.0115	= kgf/m
kgf/m	×	7.2330	= ft-lb
kgf/m	×	86.8000	= in.-lb
kgf/m	×	9.8070	= N·m
N·m	×	0.7376	= ft-lb
N·m	×	8.8510	= in.-lb
N·m	×	0.1020	= kgf/m

■ Units of pressure

PSI	×	0.0689	= bar
PSI	×	6.8950	= kPa
PSI	×	0.0703	= kg/cm ²
bar	×	14.5030	= PSI
bar	×	100.0000	= kPa
bar	×	29.5300	= inHg (60 °F)
kPa	×	0.1450	= PSI
kPa	×	0.0100	= bar
kPa	×	0.0102	= kg/cm ²
kg/cm ²	×	98.0700	= PSI
kg/cm ²	×	0.9807	= bar
kg/cm ²	×	14.2200	= kPa
in.Hg (60°)	×	0.0333	= bar
in.Hg (60°)	×	3.3770	= kPa
in.Hg (60°)	×	0.0344	= kg/cm ²
mmAq	×	0.0394	= in.Aq

■ Units of power

hp (metric or PS)	×	0.9863201	= hp SAE
hp (metric or PS)	×	0.7354988	= kW
hp SAE	×	1.0138697	= hp (metric or PS)
hp SAE	×	0.7456999	= kW
kW	×	1.3596216	= hp (metric or PS)
kW	×	1.3410221	= hp SAE

■ Units of temperature

°F = (1.8 × °C) + 32
 °C = 0.556 × (°F - 32)

Section 5

PERIODIC MAINTENANCE

	Page
Before You Begin Servicing	5-3
Introduction.....	5-4
The Importance of Periodic Maintenance.....	5-4
Performing Periodic Maintenance	5-4
YANMAR Replacement Parts.....	5-4
Required EPA/ARB Maintenance - USA Only.....	5-4
EPA/ARB Installation Requirements - USA Only	5-4
Periodic Maintenance Schedule.....	5-5
Periodic Maintenance Procedures	5-7
After Initial 50 Hours of Operation	5-7
Every 50 Hours of Operation	5-10
Every 250 Hours of Operation.....	5-13
Every 500 Hours of Operation.....	5-16
Every 1000 Hours of Operation.....	5-19
Every 1500 Hours of Operation.....	5-21
Every 2000 Hours of Operation.....	5-22
Every 3000 Hours of Operation.....	5-23

This Page Intentionally Left Blank

BEFORE YOU BEGIN SERVICING

Before performing any service procedures within this section, read the following safety information and review the *Safety section on page 3-1*.

INTRODUCTION

This section of the Service Manual describes the procedures for proper care and maintenance of the engine.

The Importance of Periodic Maintenance

Engine deterioration and wear occurs in proportion to length of time the engine has been in service and the conditions the engine is subject to during operation. Periodic maintenance prevents unexpected downtime, reduces the number of accidents due to poor machine performance and helps extend the life of the engine.

Performing Periodic Maintenance

WARNING

Exhaust hazard!



- **Never operate the engine in an enclosed area such as a garage, tunnel, underground room, manhole or ship's hold without proper ventilation.**
- **Never block windows, vents, or other means of ventilation if the engine is operating in an enclosed area. All internal combustion engines create carbon monoxide gas during operation. Accumulation of this gas within an enclosure could cause illness or even death.**
- **Make sure that all connections are tightened to specifications after repair is made to the exhaust system.**
- **Failure to comply could result in death or serious injury.**

Perform periodic maintenance procedures in an open, level area free from traffic. If possible, perform the procedures indoors to prevent environmental conditions, such as rain, wind, or snow, from damaging the machine.

YANMAR Replacement Parts

YANMAR recommends that you use genuine YANMAR parts when replacement parts are needed. Genuine replacement parts help ensure long engine life.

Required EPA/ARB Maintenance - USA Only

To maintain optimum engine performance and compliance with the Environmental Protection Agency (EPA) Regulations Non-road Engines and the California Air Resources Board (ARB, California), it is essential that you follow the *Periodic Maintenance Schedule on page 5-5* and *Periodic Maintenance Procedures on page 5-7*.

EPA/ARB Installation Requirements - USA Only

The following are the installation requirements for the EPA/ARB. Unless these requirements are met, the exhaust gas emissions will not be within the limits specified by the EPA and ARB.

Maximum Exhaust Gas Restriction shall be:

Maximum air intake restriction shall be 0.90 PSI (6.23 kPa; 635 mmAq) or less. Clean or replace the air cleaner element if the air intake restriction exceeds the above mentioned value.

PERIODIC MAINTENANCE SCHEDULE

Daily and periodic maintenance is important to keep the engine in good operating condition. The following is a summary of maintenance items by periodic maintenance intervals. Periodic maintenance intervals vary depending on engine application, loads, diesel fuel and engine oil used and are hard to establish definitively. The following should be treated only as a general guideline.

NOTICE

Establish a periodic maintenance plan according to the engine application and make sure you perform the required periodic maintenance at the intervals indicated. Failure to follow these guidelines will impair the engine's safety and performance characteristics, shorten the engine's life and may affect the warranty coverage on your engine.

The TNV series engines may inject fuel after general combustion for the purpose of self-regeneration of the DPF. This fuel may enter the oil pan through the cylinder and dilute the engine oil. Check the oil level daily. If it is above the upper limit of the dipstick, change the oil regardless of the replacement intervals.

See *YANMAR Limited Warranty in Warranty Section*.

Consult your authorized YANMAR dealer or distributor for assistance when checking items marked with a ●.

○: Check ◇: Replace ●: Contact your authorized YANMAR industrial engine dealer or distributor

System	Check item	Daily	Periodic maintenance interval						
			Every 50 hours	Every 250 hours	Every 500 hours	Every 1000 hours	Every 1500 hours	Every 2000 hours	Every 3000 hours
Cooling system	Check and refill engine coolant	○							
	Check and clean radiator fins			○					
	Check and adjust cooling fan V-belt		○ 1st time	○ 2nd and after					
	Drain, flush and refill cooling system with new coolant					◇ or every 1 year which-ever comes first*1			
Cylinder head	Adjust intake/exhaust valve clearance					●			
	Lap intake/exhaust valve seats (if required)						●		
Electrical equipment	Check indicators	○							
	Check battery		○						

○: Check ◇: Replace ●: Contact your authorized YANMAR industrial engine dealer or distributor

System	Check item	Daily	Periodic maintenance interval						
			Every 50 hours	Every 250 hours	Every 500 hours	Every 1000 hours	Every 1500 hours	Every 2000 hours	Every 3000 hours
Engine oil	Check engine oil level	○							
	Drain and fill engine oil		◇ 1st time	◇ 2nd and after					
	Replace engine oil filter			◇					
Emission control warranty	Inspect turbocharger (blower wash as necessary)								●
	Inspect, clean and test EGR valve								●
	Clean EGR lead valve								●
	Clean EGR cooler (clean to blow water/air passages)						●		
	Inspect crankcase breather system						●		
	Check and clean of soot filter								●
	Inspect and test intake throttle valve								●
Fuel	Check and refill fuel tank level	○							
	Drain fuel tank			○					
	Drain fuel filter/water separator	○*2							
	Check fuel filter/water separator	○							
	Clean fuel filter/water separator				○				
	Replace fuel filter				◇				
	Check and clean injector								○
Hoses	Replace fuel system and cooling system hoses							◇ or every 2 years	
Intake and exhaust	Clean or replace air cleaner element			○	◇				
Complete engine	Overall visual check daily	○							

*1 Whichever occurs first.

*2 Be sure to inspect and drain the fuel filter and water separator everyday.
Failure to periodically perform this maintenance may shorten the life of the engine.

Note: These procedures are considered normal maintenance and are performed at the owner's expense.

PERIODIC MAINTENANCE PROCEDURES

After Initial 50 Hours of Operation

Perform the following maintenance after the initial 50 hours of operation.

- Replace engine oil and engine oil filter
- Check and adjust cooling fan V-belt

■ Replace engine oil and engine oil filter

WARNING

Burn Hazard!



- If you must drain the engine oil while it is still hot, stay clear of the hot engine oil to avoid being burned.

- Always wear eye protection.
- Failure to comply could result in death or serious injury.

WARNING

Sudden Movement Hazard!

- Engaging the transmission or PTO at an elevated engine speed could result in unexpected movement of the equipment.
- Failure to comply could result in death or serious injury.

NOTICE

- Only use the engine oil specified. Other engine oils may affect warranty coverage, cause internal engine components to seize and/or shorten engine life.
- Prevent dirt and debris from contaminating the engine oil. Carefully clean the oil cap/dipstick and the surrounding area before you remove the cap.
- Never mix different types of engine oil. This may adversely affect the lubricating properties of the engine oil.
- Never overfill. Overfilling may result in white exhaust smoke, engine overspeed or internal damage.

NOTICE

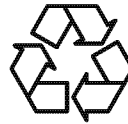

- Always be environmentally responsible.
- Follow the guidelines of the EPA or other governmental agencies for the proper disposal of hazardous materials such as engine oil, diesel fuel and engine coolant. Consult the local authorities or reclamation facility.
- Never dispose of hazardous materials irresponsibly by dumping them into a sewer, on the ground, or into ground water or waterways.
- Failure to follow these procedures may seriously harm the environment.

The engine oil in a new engine becomes contaminated from the initial break-in of internal parts. It is very important that the initial oil and filter change is performed as scheduled.

Note: The oil drain plug may be in another location if an optional oil pan is used.

Drain the engine oil as follows:

1. Make sure the engine is level.
2. Start the engine and bring it up to operating temperature.
3. Stop the engine.
4. Remove one of the oil filler caps (**Figure 5-1, (1)**) to vent the engine crankcase and allow the engine oil to drain more easily.
5. Position a container under the engine to collect waste oil.

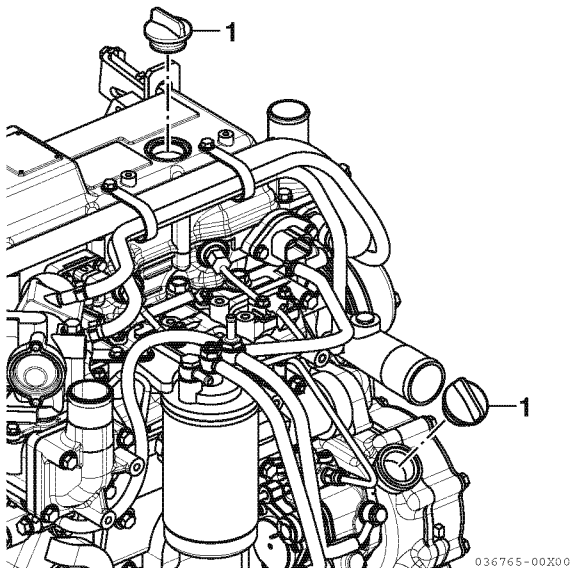
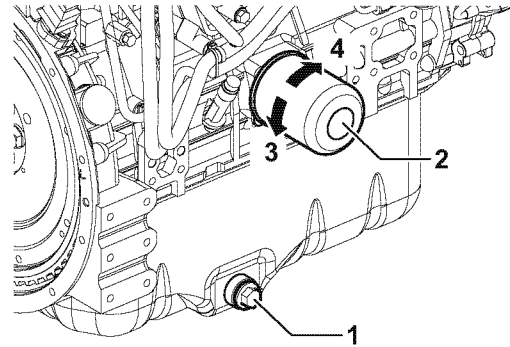

Figure 5-1

6. Remove the oil drain plug (**Figure 5-2, (1)**) from the engine oil pan. Allow oil to drain.
7. After all oil has been drained from the engine, reinstall the oil drain plug (**Figure 5-2, (1)**) and tighten to 39.8 - 47.0 ft-lb (53.9 - 63.7 N·m; 5.5 - 6.5 kgf·m).
8. Dispose of used oil properly.

Remove the engine oil filter as follows:

1. Turn the engine oil filter (**Figure 5-2, (2)**) counterclockwise (**Figure 5-2, (3)**) using a filter wrench.



042218-00X00

Figure 5-2

2. Clean the engine oil filter mounting face.
3. Lightly coat the gasket on the new oil filter with engine oil. Install the new engine oil filter manually by turning it clockwise (**Figure 5-2, (4)**) until it contacts the mounting surface. Tighten to 14 - 17 ft-lb (19.6 - 23.5 N·m; 2.0 - 2.4 kgf·m) or one additional turn using the filter wrench.

Engine oil filter Part No.	
Standard	Dust proof*
119005-35151	119005-35151

* Consult the operation manual for the driven machine for applicability of the dust proof filter.

4. Add new engine oil to the engine as specified in *Adding Engine Oil* on page 4-26.

NOTICE

- Never overfill the engine with engine oil.
- Always keep the oil level between the upper and lower lines on the oil cap/dipstick.

5. Warm up the engine by running it for five minutes and check for any engine oil leaks.
6. After engine is warm, shut it off and let it sit for 10 minutes.
7. Recheck the engine oil level.
8. Add engine oil (**Figure 5-3, (3)**) as needed until the level is between the upper and lower lines shown on the dipstick (**Figure 5-3, (1)**).

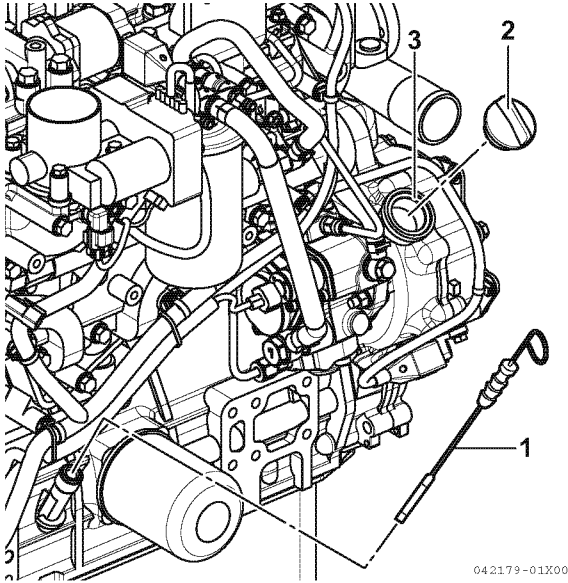

Figure 5-3

9. Reinstall the oil filler cap (**Figure 5-3, (2)**). If any engine oil is spilled, wipe it away with a clean cloth.

Check and adjust cooling fan V-belt

The V-belt will slip if it does not have the proper tension. This will prevent the alternator from generating sufficient power. Also, the engine will overheat due to the engine coolant pump pulley slipping.

Check and adjust the V-belt tension (deflection) as follows:

1. Press the V-belt down with your thumb with a force of approximately 22 ft-lb (98 N·m; 10 kgf) to check the deflection.

There are three positions to check for V-belt tension (**Figure 5-4, (A), (B)** and **(C)**). You can check the tension at whichever position is the most accessible. The proper deflection of a used V-belt at each position is:

Used V-belt tension		
A	B	C
3/8 - 1/2 in. (10 - 14 mm)	1/4 - 3/8 in. (7 - 10 mm)	5/16 - 1/2 in. (9 - 13 mm)

Note: A "Used V-belt" refers to a V-belt which has been used on a running engine for five minutes or more.

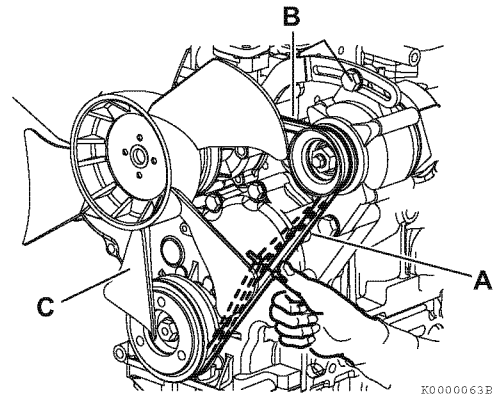

Figure 5-4

2. If necessary, adjust the V-belt tension. Loosen the adjusting bolt (**Figure 5-5, (1)**) and the other related bolts and/or nuts, then move the alternator (**Figure 5-5, (2)**) with a pry bar (**Figure 5-5, (3)**) to tighten the V-belt to the desired tension. Then tighten the adjusting bolts and/or nuts.

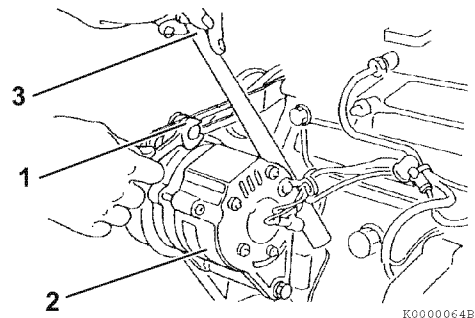

Figure 5-5

- Tighten the V-belt to the proper tension. There must be clearance (**Figure 5-6, (1)**) between the V-belt and the bottom of the pulley groove. If there is no clearance (**Figure 5-6, (2)**) between the V-belt and the bottom of the pulley groove, replace the V-belt.

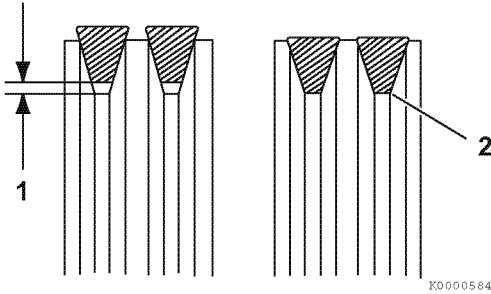

Figure 5-6

- Check the V-belt for cracks, oil or wear. If any of these conditions exist, replace the V-belt.
- Install the new V-belt. Refer to the table for proper tension.

New V-belt tension		
A	B	C
5/16 - 7/16 in. (8 - 12 mm)	3/16 - 5/16 in. (5 - 8 mm)	1/4 - 7/16 in. (7 - 11 mm)

- After adjusting, run the engine for 5 minutes or more. Check the tension again using the specifications for a used V-belt.

Used V-belt tension		
A	B	C
3/8 - 1/2 in. (10 - 14 mm)	1/4 - 3/8 in. (7 - 10 mm)	5/16 - 1/2 in. (9 - 13 mm)

Every 50 Hours of Operation

After you complete the initial 50 hour maintenance procedures, perform the following procedures every 50 hours thereafter.

- Drain fuel filter/water separator
- Check battery
- Drain fuel filter/water separator

⚠ DANGER

Fire and Explosion Hazard!



- Diesel fuel is flammable and explosive under certain conditions.
- When you remove any fuel system component to perform maintenance (such as changing the fuel filter) place an approved container under the opening to catch the fuel.
- Never use a shop rag to catch the fuel. Vapors from the rag are flammable and explosive.
- Wipe up any spills immediately.
- Wear eye protection. The fuel system is under pressure and fuel could spray out when you remove any fuel system component.
- Failure to comply will result in death or serious injury.

NOTICE

If the fuel filter/water separator is positioned higher than the fuel level in the fuel tank, water may not drip out when the fuel filter/water separator drain cock is opened. If this happens, turn the air vent screw on the top of the fuel filter/water separator 2 - 3 turns counterclockwise.

Be sure to tighten the air vent screw after the water has drained out.

NOTICE



- Be sure to perform periodic maintenance in a clean environment free from dust.

- Always be environmentally responsible.
- Follow the guidelines of the EPA or other governmental agencies for the proper disposal of hazardous materials such as engine oil, diesel fuel and engine coolant. Consult the local authorities or reclamation facility.
- Never dispose of hazardous materials irresponsibly by dumping them into a sewer, on the ground, or into ground water or waterways.
- Failure to follow these procedures may seriously harm the environment.
- Be sure to check water in the fuel filter/water separator daily. The fuel system in the common rail system is extremely high-pressured. If water is mixed to the supplied fuel in the supply pump, seizure to the supply pump and the injector may result.

Drain the fuel filter/water separator whenever there are contaminants, such as water, collected in the bottom of the cup. Never wait until the scheduled periodic maintenance if contaminants are discovered.

The cup of the separator is made from semi-transparent material. In the cup is a red colored float ring. The float ring will rise to the surface of the water to show how much needs to be drained. Also, some optional fuel filter/water separators are equipped with a sensor to detect the amount of contaminants. This sensor sends a signal to an indicator to alert the operator.

Drain the fuel filter/water separator as follows:

1. Position an approved container under the fuel filter/water separator (**Figure 5-7, (1)**) to collect the contaminants.

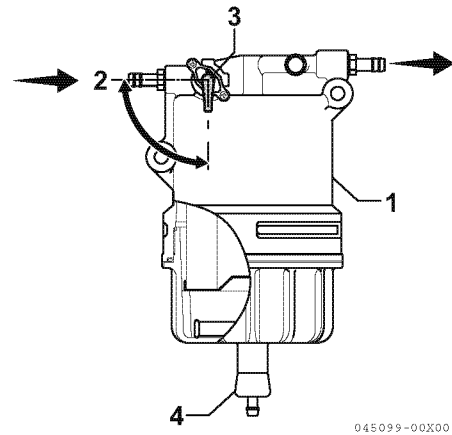

045099-00X00

Figure 5-7

2. Close (**Figure 5-7, (2)**) the fuel cock (**Figure 5-7, (3)**).
3. Loosen the drain cock (**Figure 5-7, (4)**) at the bottom of the fuel filter/water separator. Drain any water collected inside.
4. Hand-tighten the drain cock (tightening torque: $1.5 \pm 0.5 \text{ N}\cdot\text{m}$).

NOTICE

If the fuel filter/water separator is positioned higher than the fuel level in the fuel tank, water may not drip out when the fuel filter/water separator drain cock is opened. If this happens, turn the air vent screw on the top of the fuel filter/water separator 2 - 3 turns counterclockwise.

Be sure to tighten the air vent screw after the water has drained out.

5. Open the fuel cock (**Figure 5-7, (3)**).
6. Be sure to prime the diesel fuel system when you are finished. *See Priming the Fuel System on page 4-24.*
7. Check for leaks.

■ Check battery

⚠ DANGER

Explosion Hazard!



- Never check the remaining battery charge by shorting out the terminals. This will result in a spark and may cause an explosion or fire. Use a hydrometer to check the remaining battery charge.

- If the electrolyte is frozen, slowly warm the battery before you recharge it.
- Failure to comply will result in death or serious injury.

⚠ WARNING

Burn Hazard!



- Batteries contain sulfuric acid. Never allow battery fluid to come in contact with clothing, skin or eyes. Severe burns could result. Always wear safety goggles and protective clothing when servicing the battery. If battery fluid contacts the eyes and/or skin, immediately flush the affected area with a large amount of clean water and obtain prompt medical treatment.

- Failure to comply could result in death or serious injury.

NOTICE

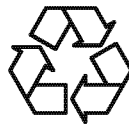

- Always be environmentally responsible.

- Follow the guidelines of the EPA or other governmental agencies for the proper disposal of hazardous materials such as engine oil, diesel fuel and engine coolant. Consult the local authorities or reclamation facility.
- Never dispose of hazardous materials irresponsibly by dumping them into a sewer, on the ground, or into ground water or waterways.
- Failure to follow these procedures may seriously harm the environment.

- When the amount of fluid nears the lower limit (Figure 5-8, (3)), fill with distilled water (Figure 5-8, (2)) so it is at the upper limit (Figure 5-8, (1)). If operation continues with insufficient battery fluid, the battery life is shortened, and the battery may overheat and explode. During the summer, check the fluid level more often than specified.

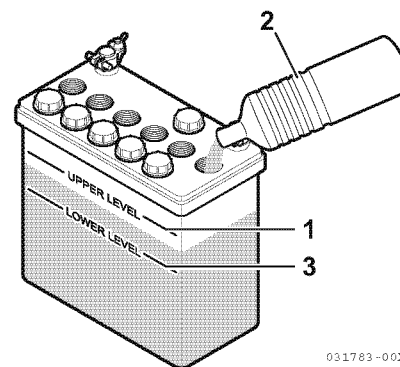

031783-00X

Figure 5-8

- If the engine cranking speed is so slow that the engine does not start, recharge the battery.
- If the engine still will not start after charging, have your authorized YANMAR industrial engine dealer or distributor check the battery and the engine's starting system.
- If operating the machine where the ambient temperature could drop to 5 °F (-15 °C) or less, remove the battery from the machine at the end of the day. Store the battery in a warm place until the next use. This will help start the engine easily at low ambient temperatures.

Every 250 Hours of Operation

Perform the following maintenance every 250 hours of operation.

- Drain fuel tank
- Replace engine oil and engine oil filter
- Check and clean radiator fins
- Check and adjust cooling fan V-belt
- Clean air cleaner element

■ Drain fuel tank

DANGER

Fire and Explosion Hazard!



- Diesel fuel is flammable and explosive under certain conditions.

- When you remove any fuel system component to perform maintenance (such as changing the fuel filter) place an approved container under the opening to catch the fuel.
- Never use a shop rag to catch the fuel. Vapors from the rag are flammable and explosive.
- Wipe up any spills immediately.
- Wear eye protection. The fuel system is under pressure and fuel could spray out when you remove any fuel system component.
- Failure to comply will result in death or serious injury.

NOTICE

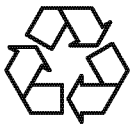

- Always be environmentally responsible.

- Follow the guidelines of the EPA or other governmental agencies for the proper disposal of hazardous materials such as engine oil, diesel fuel and engine coolant. Consult the local authorities or reclamation facility.
- Never dispose of hazardous materials irresponsibly by dumping them into a sewer, on the ground, or into ground water or waterways.
- Failure to follow these procedures may seriously harm the environment.

Note that a typical fuel tank is illustrated.

1. Position an approved container under the diesel fuel tank (**Figure 5-9, (1)**) to collect the contaminants.
2. Remove the fuel cap (**Figure 5-9, (3)**).
3. Remove the drain plug (**Figure 5-9, (2)**) of the fuel tank to drain the contaminants (water, dirt, etc.) from the bottom of the tank.

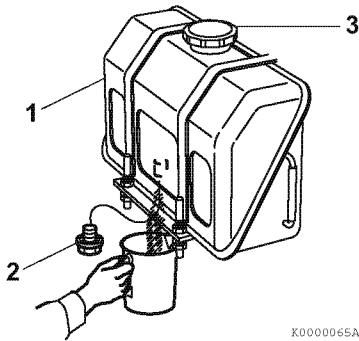

Figure 5-9

4. Drain the tank until clean diesel fuel with no water and dirt flows out. Reinstall and tighten the drain plug firmly.
5. Reinstall the fuel cap.
6. Check for leaks.

■ Replace engine oil and engine oil filter

NOTICE

- Only use the engine oil specified. Other engine oils may affect warranty coverage, cause internal engine components to seize and/or shorten engine life.
- Prevent dirt and debris from contaminating the engine oil. Carefully clean the oil cap/dipstick and the surrounding area before you remove the cap.
- Never mix different types of engine oil. This may adversely affect the lubricating properties of the engine oil.
- Never overfill. Overfilling may result in white exhaust smoke, engine overspeed or internal damage.

NOTICE

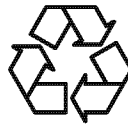

- Always be environmentally responsible.

- Follow the guidelines of the EPA or other governmental agencies for the proper disposal of hazardous materials such as engine oil, diesel fuel and engine coolant. Consult the local authorities or reclamation facility.
- Never dispose of hazardous materials irresponsibly by dumping them into a sewer, on the ground, or into ground water or waterways.
- Failure to follow these procedures may seriously harm the environment.

Change the engine oil every 250 hours of operation after the initial change at 50 hours. Replace the engine oil filter at the same time. See *Replace engine oil and engine oil filter* on page 5-7.

■ Check and clean radiator fins

CAUTION

Flying Object Hazard!

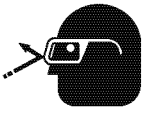

- Always wear eye protection when servicing the engine and when using compressed air or high-pressure water. Dust, flying debris, compressed air, pressurized water or steam may injure your eyes.

- Failure to comply may result in minor or moderate injury.

Dirt and dust adhering to the radiator fins reduce the cooling performance, causing overheating. Make it a rule to check the radiator fins daily and clean as needed.

Note that a typical radiator is shown in **Figure 5-10** for illustrative purposes only.

- Blow off dirt and dust from fins and radiator with 28 PSI (0.19 MPa; 2 kgf/cm²) or less of compressed air (**Figure 5-10, (1)**). Be careful not to damage the fins with the compressed air.
- If there is a large amount of contamination on the fins, apply detergent, thoroughly clean and rinse with tap water.

NOTICE

Never use high-pressure water or compressed air at greater than 28 PSI (193 kPa; 19 686 mmAq) or a wire brush to clean the radiator fins. Radiator fins damage easily.

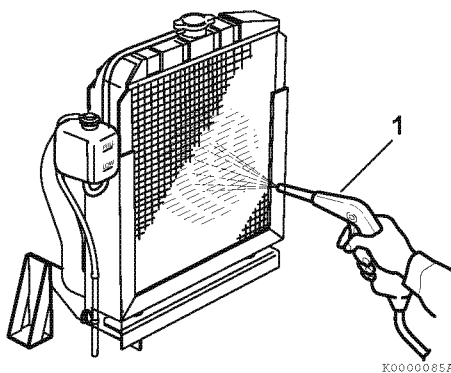

Figure 5-10

■ Check and adjust cooling fan V-belt

Check and adjust the cooling fan V-belt every 250 hours of operation after the initial 50 hour V-belt maintenance. See *Check and adjust cooling fan V-belt on page 5-9*.

■ Clean air cleaner element

CAUTION

Flying Object Hazard!

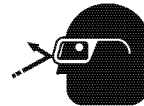

- Always wear eye protection when servicing the engine and when using compressed air or high-pressure water. Dust, flying debris, compressed air, pressurized water or steam may injure your eyes.

- Failure to comply may result in minor or moderate injury.

Note that a typical air cleaner is shown in **Figure 5-11** and **Figure 5-12** for illustrative purposes only.

The engine performance is adversely affected when the air cleaner element is clogged with dust. Be sure to clean the air filter element periodically.

1. Unlatch and remove the air cleaner cover (**Figure 5-11, (1)**).

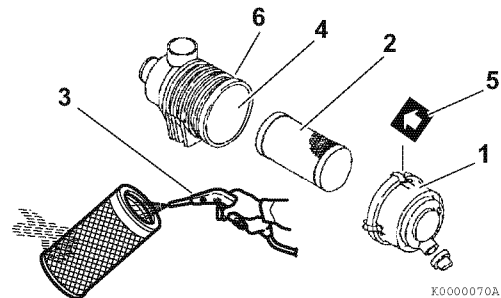

Figure 5-11

2. Remove the element (**Figure 5-11, (2)**) (outer element if equipped with two elements).
3. Blow air (**Figure 5-11, (3)**) through the element from the inside out using 42 - 71 PSI (0.29 - 0.49 MPa; 3.0 - 5.0 kgf/cm²) compressed air to remove the particulates. Use the lowest possible air pressure to remove the dust without damaging the element.

4. If the air cleaner is equipped with a double element, only remove and replace the inner element (**Figure 5-12, (1)**) if the engine lacks power or the dust indicator actuates (if equipped).

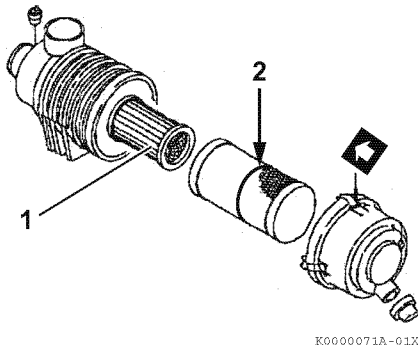

Figure 5-12

5. The inner element should not be removed when cleaning or replacing the outer element. The inner element is used to prevent dust from entering the engine while servicing the outer element.
6. Replace the element with a new one if the element is damaged, excessively dirty or oily.
7. Clean inside of the air cleaner cover.
8. Install the element into the air cleaner case (**Figure 5-11, (4)**).
*Note: If there is a red line (**Figure 5-12, (2)**) in the outer element, reinsert the element until the overlap position of red line and end face of the air cleaner case.*
9. Reinstall the air cleaner cover making sure you match the arrow (**Figure 5-11, (5)**) on the cover with the arrow on the case (**Figure 5-11, (6)**).
10. Latch the air cleaner cover to the case.

NOTICE

- When the engine is operated in dusty conditions, clean the air cleaner element more frequently.
- Never operate the engine with the air cleaner element(s) removed. This may allow foreign material to enter the engine and damage it.

Every 500 Hours of Operation

Perform the following maintenance every 500 hours of operation.

- Replace air cleaner element
 - Replace fuel filter
 - Replace element of fuel filter/water separator
- Replace air cleaner element

NOTICE

The maximum air intake restriction, in terms of differential pressure measurement, must not exceed 0.90 PSI (6.23 kPa; 635 mmAq). Clean or replace the air cleaner element if the air intake restriction exceeds the above mentioned value.

Replace the air cleaner element (**Figure 5-11, (2)**) every 500 hours even if it is not damaged or dirty.

When replacing the element, clean the inside of the air cleaner case (**Figure 5-11, (4)**).

If the air cleaner is equipped with a double element, *only remove and replace the inner element (**Figure 5-12, (1)**) if the engine lacks power or the dust indicator actuates (if equipped)*. This is in addition to replacing the outer element.

■ Replace fuel filter

▲ DANGER

Fire and Explosion Hazard!



- Diesel fuel is flammable and explosive under certain conditions.

- When you remove any fuel system component to perform maintenance (such as changing the fuel filter) place an approved container under the opening to catch the fuel.
- Never use a shop rag to catch the fuel. Vapors from the rag are flammable and explosive.
- Wipe up any spills immediately.
- Wear eye protection. The fuel system is under pressure and fuel could spray out when you remove any fuel system component.
- Failure to comply will result in death or serious injury.

NOTICE

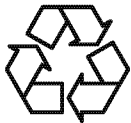

- Always be environmentally responsible.

- Follow the guidelines of the EPA or other governmental agencies for the proper disposal of hazardous materials such as engine oil, diesel fuel and engine coolant. Consult the local authorities or reclamation facility.
- Never dispose of hazardous materials irresponsibly by dumping them into a sewer, on the ground, or into ground water or waterways.
- Failure to follow these procedures may seriously harm the environment.

NOTICE

For maximum engine life, YANMAR recommends that when shutting the engine down, you allow the engine to idle, without load, for five minutes. This will allow the engine components that operate at high temperatures, such as the turbocharger (if equipped) and exhaust system, to cool slightly before the engine itself is shut down.

Replace the fuel filter at specified intervals to prevent contaminants from adversely affecting the diesel fuel flow.

1. Stop the engine and allow it to cool.
2. Close the fuel cock of the fuel filter/water separator.
3. Remove the fuel filter with a filter wrench, turning it to the left (**Figure 5-13, (1)**). When removing the fuel filter, carefully hold it to prevent the fuel from spilling. Wipe up all spilled fuel.

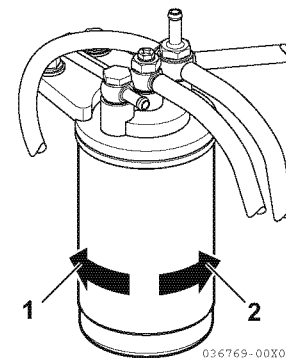

Figure 5-13

4. Clean the filter mounting surface and apply a small amount of diesel fuel to the gasket of the new fuel filter.
5. Install the new fuel filter. Turn to the right (**Figure 5-13, (2)**) and hand-tighten it only until it comes in contact with the mounting surface. Tighten to 20 - 24 N·m (2.0 - 2.4 kgf·m) or one additional turn using the filter wrench.

Applicable fuel filter Part No.	129A00-55610
---------------------------------	--------------

* Consult the operation manual for the driven machine for applicability of the dust proof filter.

6. Open the fuel cock of the fuel filter/water separator.
7. Prime the fuel system. See *Priming the Fuel System on page 4-24*.
8. Check for leaks.

■ **Replace element of fuel filter/water separator**

⚠ DANGER

Fire and Explosion Hazard!



- Diesel fuel is flammable and explosive under certain conditions.

- Never use diesel fuel as a cleaning agent.
- When you remove any fuel system component to perform maintenance (such as changing the fuel filter) place an approved container under the opening to catch the fuel.
- Never use a shop rag to catch the fuel. Vapors from the rag are flammable and explosive.
- Wipe up any spills immediately.
- Wear eye protection. The fuel system is under pressure and fuel could spray out when you remove any fuel system component.
- Failure to comply will result in death or serious injury.

NOTICE

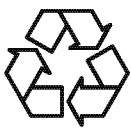

- Always be environmentally responsible.

- Follow the guidelines of the EPA or other governmental agencies for the proper disposal of hazardous materials such as engine oil, diesel fuel and engine coolant. Consult the local authorities or reclamation facility.
- Never dispose of hazardous materials irresponsibly by dumping them into a sewer, on the ground, or into ground water or waterways.
- Failure to follow these procedures may seriously harm the environment.

Periodically replace the fuel filter/water separator element and inside cup.

1. Position an approved container under the cup (**Figure 5-14, (1)**) of the fuel filter/water separator to collect the contaminants.

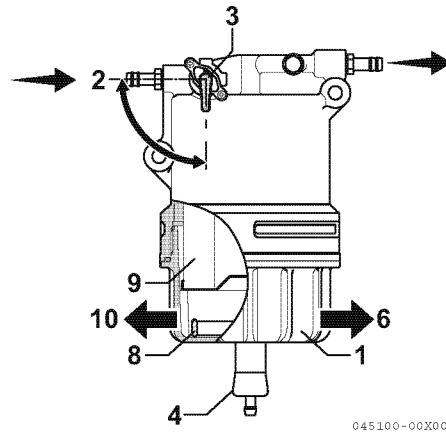

Figure 5-14

2. Close (**Figure 5-14, (2)**) the fuel cock (**Figure 5-14, (3)**).
 3. Loosen the drain cock (**Figure 5-14, (4)**) and drain the contaminants. See *Drain fuel filter/water separator on page 5-10*.
 4. Turn the retaining ring to the left (**Figure 5-14, (10)**) and remove the cup. If equipped, disconnect the sensor wire from the cup before removing the cup.
 5. Carefully hold the cup to prevent fuel from spilling. If you spill any fuel, clean up the spill completely.
 6. Remove the float ring (**Figure 5-14, (8)**) from the cup. Pour the contaminants into the container and dispose of it properly.
 7. Replace the element into the top of filter.
- | | |
|-----------------------------|--------------|
| Applicable element Part No. | 129242-55730 |
|-----------------------------|--------------|
8. Install the element and O-ring in the cup.
 9. Position the float ring in the cup.
 10. Check the condition of the cup O-ring. Replace if necessary.
 11. Install the cup to the bracket by tightening the retaining ring to the right (**Figure 5-14, (6)**) to a torque of 27 - 33 N·m (2.8 - 3.4 kgf·m).
 12. Close the drain cock. Reconnect the sensor wire if equipped.

13. Open the fuel cock (Figure 5-14, (3)).
14. Prime the fuel system. See *Priming the Fuel System* on page 4-24.

NOTICE

Be sure to perform priming. If air is mixed to the fuel, seizure to the supply pump and the injector may result.

15. Check for leaks.

Every 1000 Hours of Operation

Perform the following maintenance every 1000 hours of operation.

- Drain, flush and refill cooling system with new coolant
- Adjust intake/exhaust valve clearance
- Drain, flush and refill cooling system with new coolant

⚠ DANGER

Scald Hazard!



- Never remove the radiator cap if the engine is hot. Steam and hot engine coolant will spurt out and seriously burn you. Allow the engine to cool down before you attempt to remove the radiator cap.
- Tighten the radiator cap securely after you check the radiator. Steam can spurt out during engine operation if the cap is loose.
- Always check the level of the engine coolant by observing the reserve tank.
- Failure to comply will result in death or serious injury.

⚠ WARNING

Burn Hazard!



- Wait until the engine cools before you drain the engine coolant. Hot engine coolant may splash and burn you.
- Failure to comply could result in death or serious injury.

CAUTION

Coolant Hazard!

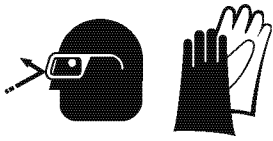

- Wear eye protection and rubber gloves when you handle long life or extended life engine coolant. If contact with the eyes or skin should occur, flush eyes and wash immediately with clean water.

- Failure to comply may result in minor or moderate injury.

NOTICE



- Always be environmentally responsible.

- Follow the guidelines of the EPA or other governmental agencies for the proper disposal of hazardous materials such as engine oil, diesel fuel and engine coolant. Consult the local authorities or reclamation facility.
- Never dispose of hazardous materials irresponsibly by dumping them into a sewer, on the ground, or into ground water or waterways.
- Failure to follow these procedures may seriously harm the environment.

Engine coolant contaminated with rust or scale reduces the cooling effect. Even when extended life engine coolant is properly mixed, the engine coolant gets contaminated as its ingredients deteriorate. Drain, flush and refill the cooling system with new coolant every 1000 hours or once a year, whichever comes first.

1. Allow engine and coolant to cool.
2. Remove the radiator cap (**Figure 5-15, (1)**).
3. Remove the drain plug or open the drain cock (**Figure 5-15, (2)**) at the lower portion of the radiator and drain the engine coolant.

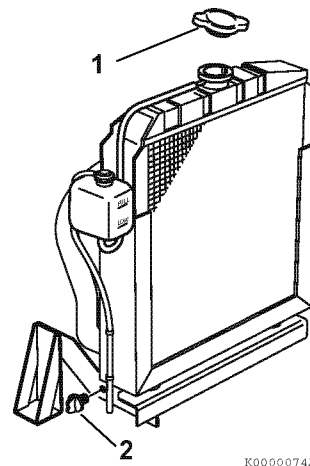

Figure 5-15

4. Drain the coolant from the engine block.

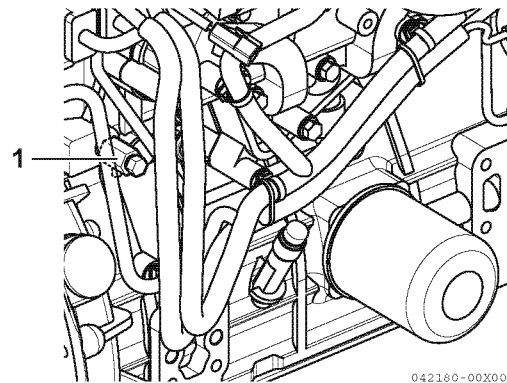

Figure 5-16

5. After draining the engine coolant, flush the radiator and engine block to remove any rust, scale and contaminants. Then reinstall and tighten the drain plug or close the drain cock in the radiator. Reinstall and tighten the cylinder block drain plug or reconnect the coolant hose at the oil cooler.
6. Fill radiator and engine with engine coolant. *See Filling Radiator with Engine Coolant on page 4-28.*

Adjust intake/exhaust valve clearance

Proper adjustment is necessary to maintain the correct timing for opening and closing the valves. Improper adjustment will cause the engine to run noisily, resulting in poor engine performance and engine damage. *See Intake/Exhaust Valve and Guide on page 6-5.*

Every 1500 Hours of Operation

Perform the following maintenance every 1500 hours of operation.

- Clean EGR cooler
- Inspect crankcase breather system

■ Clean EGR cooler

The EGR cooler is apt to be contaminated with rust and scale that deteriorate the cooling performance. Carbon accumulation in the exhaust gas passage of the cooler hinders circulation of exhaust gas, resulting in deterioration in exhaust gas cleanup performance.

To prevent such a problem, clean the cooler at least every 1500 hours.

Consult your local YANMAR dealer for this service.

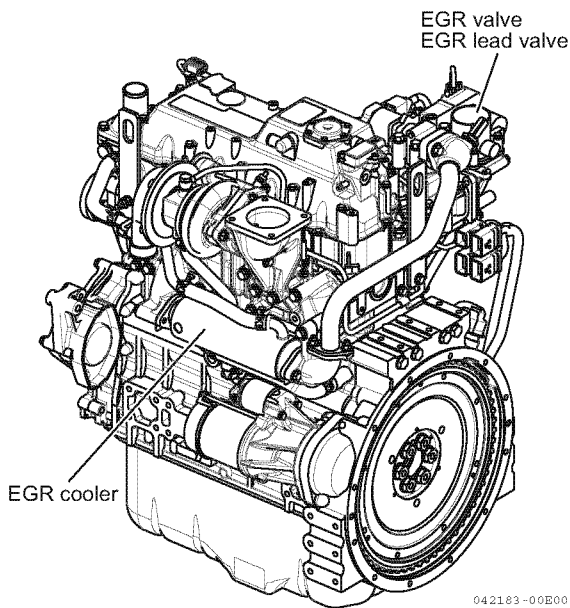

Figure 5-17

■ Inspect crankcase breather system

Proper operation of the crankcase breather system is required to maintain the emission requirements of the engine. The EPA/ARB requires that the crankcase breather system is inspected every 1500 hours.

There are three different crankcase breather systems used on the TNV engines. Only the non-turbo TNV engines crankcase breather system requires periodic maintenance.

The non-turbo TNV engines use a crankcase breather system that has a spring-backed diaphragm (**Figure 5-18, (1)**) in the valve cover (**Figure 5-18, (2)**). When the crankcase pressure reaches a predetermined value, the diaphragm opens a passage that allows crankcase fumes to be routed to the intake manifold.

To inspect the diaphragm and spring (**Figure 5-18, (3)**):

1. Remove the bolts retaining the diaphragm cover (**Figure 5-18, (4)**).

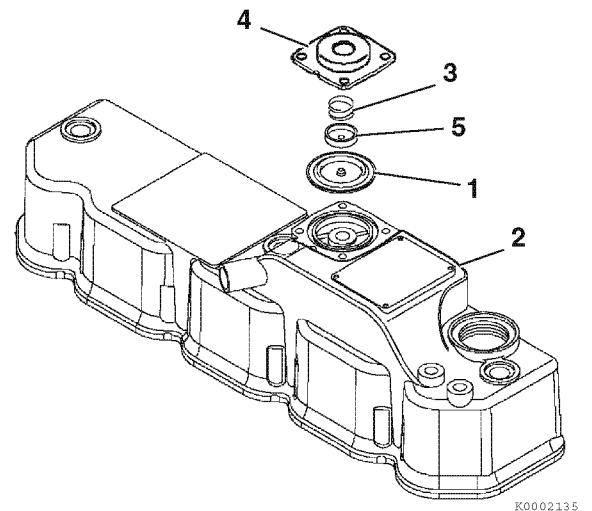

Figure 5-18

2. Remove the diaphragm cover, spring, diaphragm plate (**Figure 5-18, (5)**) and diaphragm.
3. Inspect the diaphragm for tears. Inspect the spring for distortion. Replace components if necessary.

4. Reinstall the diaphragm, diaphragm plate, spring and diaphragm cover. Tighten the diaphragm bolts to specified torque.

Failure of the diaphragm and/or spring will cause the loss of pressure control and allow an excessive amount of crankcase fumes to be routed to the intake manifold. This could result in excessive deposits in the intake system, high engine exhaust smoke levels, excessive engine oil consumption, and/or engine run-on due to the burning of the engine oil.

Every 2000 Hours of Operation

Perform the following maintenance every 2000 hours of operation.

- **Check and replace fuel hoses and engine coolant hoses**
- **Lap the intake and exhaust valves. If necessary**
- **Check and replace fuel hoses and engine coolant hoses**

NOTICE

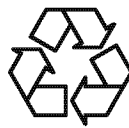

- Always be environmentally responsible.

- Follow the guidelines of the EPA or other governmental agencies for the proper disposal of hazardous materials such as engine oil, diesel fuel and engine coolant. Consult the local authorities or reclamation facility.
- Never dispose of hazardous materials irresponsibly by dumping them into a sewer, on the ground, or into ground water or waterways.
- Failure to follow these procedures may seriously harm the environment.

Regularly check the fuel system and engine coolant system hoses. If they are cracked or degraded, replace them. Replace the hoses at least every two years.

■ **Lap the intake and exhaust valves**

Adjustment is necessary to maintain proper contact of the valves and seats. *See Inspection of intake and exhaust valves on page 6-33.*

Every 3000 Hours of Operation

Perform the following maintenance every 3000 hours of operation.

- **Inspect turbocharger (Blower wash as necessary)**
- **Inspect, clean and test EGR valve**
- **Inspect and clean EGR lead valve**
- **Inspect and test Intake throttle valve**
- **Check and clean DPF (Soot filter)**
- **Check and clean injector**

■ Inspect turbocharger (Blower wash as necessary)

Turbocharger service is required by the EPA/ARB every 3000 hours. Inspect, clean and blower wash the unit if necessary (see *Periodic Inspection on page 10-11*). If you notice that the engine seems sluggish or the exhaust color is abnormal never wait until the next service interval.

■ Inspect, clean and test EGR valve

The EGR valve is a key component for cleaning exhaust gas.

To prevent the valve from deteriorating in exhaust gas recirculation performance due to carbon accumulation, inspect, clean and test the valve at least every 3000 hours.

Consult your local YANMAR dealer for this service.

■ Inspect and clean EGR lead valve

The EGR lead valve is located in the passage of recirculated gas.

To prevent carbon accumulation in or clogging of the lead valve, inspect and clean the lead valve at regular intervals.

Consult your local YANMAR dealer for this service.

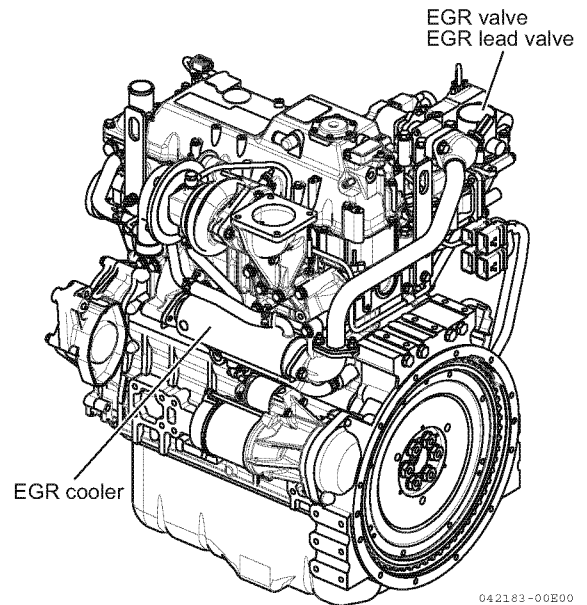

Figure 5-19

■ Inspect and test Intake throttle valve

The intake throttle valve is located at inlet of intake manifold.

The intake throttle valve is one of key component for regeneration of DPF.

It is recommended to check and test for every 3000 hours.

■ Check and clean DPF (Soot filter)

The DPF is an important part in terms of compliance with the emission control regulations. Periodic cleaning of the filter (soot filter) is required to restrain the loss of pressure caused by the accumulated metal composition including ash in the filter and to maintain the engine performance. YANMAR recommends cleaning per every 3,000 hours of operation.

For details, contact your nearest YANMAR service dealer.

■ Check and clean injector

Check the injector tip. Clean the injector tip with a soft brush or replace it if necessary.

This Page Intentionally Left Blank

Section 6

ENGINE

	Page
Before You Begin Servicing	6-3
Introduction.....	6-4
Cylinder Head Specifications	6-4
Adjustment Specifications	6-4
Cylinder Head.....	6-4
Intake/Exhaust Valve and Guide	6-5
Push Rod.....	6-6
Rocker Arm and Shaft	6-6
Valve Spring	6-6
Camshaft and Timing Gear Train Specifications.....	6-7
Camshaft.....	6-7
Idle Gear Shaft and Bushing	6-8
Timing Gear Backlash	6-8
Crankshaft and Piston Specifications.....	6-9
Crankshaft.....	6-9
Thrust Bearing.....	6-10
Piston.....	6-10
Piston Ring	6-11
Connecting Rod.....	6-14
Tappet	6-14
Cylinder Block Specifications	6-15
Cylinder Block.....	6-15
Special Torque Chart	6-16
Torque for Bolts and Nuts.....	6-16
Special Service Tools.....	6-19
Measuring Instruments.....	6-23
Cylinder Head.....	6-25
Cylinder Head Components	6-25

ENGINE

Components of a Cylinder Head	6-26
Disassembly of Cylinder Head	6-27
Cleaning of Cylinder Head Components	6-31
Inspection of Cylinder Head Components.....	6-31
Reassembly of Cylinder Head.....	6-36
Measuring and Adjusting Valve Clearance	6-40
Crankshaft and Camshaft Components	6-42
Disassembly of Engine.....	6-43
Disassembly of Camshaft and Timing Components	6-44
Disassembly of Crankshaft and Piston Components	6-48
Inspection of Crankshaft and Camshaft Components.....	6-51
Honing and Boring.....	6-57
Reassembly of Crankshaft and Piston Components.....	6-58
Reassembly of Camshaft and Timing Components	6-64
Final Reassembly of Engine.....	6-67
EGR System	6-68
EGR System (Typical Model)	6-68
Typical Model for Turbocharger Model.....	6-69
EGR System.....	6-70

BEFORE YOU BEGIN SERVICING

Before performing any service procedures within this section, read the following safety information and review the *Safety* section on page 3-1.

INTRODUCTION

This section of the Service Manual describes servicing of the engine.

CYLINDER HEAD SPECIFICATIONS

Adjustment Specifications

Model	Valve clearance
All models	0.006 - 0.010 in. (0.15 - 0.25 mm)

Cylinder Head

Inspection item		Standard	Limit	Reference page
Combustion surface distortion (flatness)		0.0020 in. (0.05 mm) or less	0.0059 in. (0.15 mm)	
Valve recession	3TNV88C, 3TNV86CT, 4TNV88C, 4TNV86CT	Intake	0.0118 - 0.0197 in. (0.30 - 0.50 mm)	See Valve recession on page 6-34.
		Exhaust	0.0118 - 0.0197 in. (0.30 - 0.50 mm)	
	4TNV98C, 4TNV98CT	Intake	0.0142 - 0.0220 in. (0.36 - 0.56 mm)	
		Exhaust	0.0138 - 0.0217 in. (0.35 - 0.55 mm)	
Valve seat	Seat angle	Intake	120°	See Valve face and valve seat on page 6-34.
		Exhaust	90°	
	Seat correction angle	40°, 150°	—	

Intake/Exhaust Valve and Guide

Inspection item			Standard	Limit	Reference page
3TNV88C, 3TNV86CT, 4TNV88, 4TNV86CT	Intake	Guide inside diameter	0.3154 - 0.3159 in. (8.010 - 8.025 mm)	0.3189 in. (8.10 mm)	<i>See Inspection of valve guides on page 6-33.</i>
		Valve stem outside diameter	0.3132 - 0.3140 in. (7.955 - 7.975 mm)	0.3110 in. (7.90 mm)	
		Valve stem bend	0.0014 - 0.0028 in. (0.035 - 0.070 mm)	0.0071 in. (0.18 mm)	
	Exhaust	Guide inside diameter	0.3156 - 0.3161 in. (8.015 - 8.030 mm)	0.3189 in. (8.10 mm)	
		Valve stem outside diameter	0.3132 - 0.3134 in. (7.955 - 7.960 mm)	0.3110 in. (7.90 mm)	
		Valve stem bend	0.0018 - 0.0030 in. (0.045 - 0.075 mm)	0.0071 in. (0.18 mm)	
4TNV98C, 4TNV98CT	Intake	Guide inside diameter	0.2756 - 0.2762 in. (7.000 - 7.015 mm)	0.2787 in. (7.08 mm)	<i>See Inspection of valve guides on page 6-33.</i>
		Valve stem outside diameter	0.2734 - 0.2740 in. (6.945 - 6.960 mm)	0.2717 in. (6.90 mm)	
		Oil clearance	0.0016 - 0.0028 in. (0.040 - 0.070 mm)	0.0067 in. (0.17 mm)	
	Exhaust	Guide inside diameter	0.2756 - 0.2762 in. (7.000 - 7.015 mm)	0.2787 in. (7.08 mm)	
		Valve stem outside diameter	0.2732 - 0.2738 in. (6.940 - 6.955 mm)	0.2717 in. (6.90 mm)	
		Valve stem bend	0.0018 - 0.0030 in. (0.045 - 0.075 mm)	0.0067 in. (0.17 mm)	
Valve guide projection from cylinder head		3TNV88C, 3TNV86CT, 4TNV88C, 4TNV86CT, 4TNV98C, 4TNV98CT	0.5791 - 0.5905 in. (14.71 - 15.00 mm)	—	<i>See Reassembly of valve guides on page 6-36.</i>
Valve guide installation method			Cold-fitted	—	
Valve stem seal projection from cylinder head		3TNV88C, 3TNV86CT, 4TNV88C, 4TNV86CT, 4TNV98C, 4TNV98CT	0.736 - 0.748 in. (18.7 - 19.0 mm)	—	<i>See Reassembly of intake and exhaust valves on page 6-36</i>

Push Rod

Inspection item	Standard	Limit	Reference page
Push rod bend - all models	Less than 0.0012 in. (0.03 mm)	0.0012 in. (0.03 mm)	See Push rod bend on page 6-32.

Rocker Arm and Shaft

Model	Inspection item	Standard	Limit	Reference page
3TNV88C, 3TNV86CT, 4TNV88C, 4TNV86CT	Arm shaft hole diameter	0.6299 - 0.6307 in. (16.000 - 16.020 mm)	0.6327 in. (16.07 mm)	See Inspection of rocker arm assembly on page 6-32.
	Shaft outside diameter	0.6286 - 0.6293 in. (15.966 - 15.984 mm)	0.6276 in. (15.94 mm)	
	Oil clearance	0.0006 - 0.0021 in. (0.016 - 0.054 mm)	0.0051 in. (0.13 mm)	
4TNV98, 4TNV98CT	Arm shaft hole diameter	0.7283 - 0.7291 in. (18.500 - 18.520 mm)	0.7311 in. (18.57 mm)	
	Shaft outside diameter	0.7272 - 0.7280 in. (18.470 - 18.490 mm)	0.7260 in. (18.44 mm)	
	Oil clearance	0.0004 - 0.0020 in. (0.010 - 0.050 mm)	0.0051 in. (0.13 mm)	

Valve Spring

Inspection item	Model	Standard	Limit	Reference page
Free length	3TNV88C, 3TNV86CT, 4TNV88C, 4TNV86CT	1.6535 in. (42.0 mm)	1.6339 in. (41.5 mm)	See Inspection of valve springs on page 6-35.
	4TNV98C, 4TNV98CT	1.8701 in. (47.5 mm)	1.8504 in. (47.0 mm)	
Squareness	3TNV88C, 3TNV86CT, 4TNV88C, 4TNV86CT	—	0.0551 in. (1.4 mm)	
	4TNV98C, 4TNV98CT	—	0.0472 in. (1.2 mm)	

CAMSHAFT AND TIMING GEAR TRAIN SPECIFICATIONS

Camshaft

Inspection item		Standard	Limit	Reference page	
End play		0.0020 - 0.0079 in. (0.05 - 0.20 mm)	0.0118 in. (0.030 mm)	See Removal of camshaft on page 6-46.	
Bend (1/2 the dial gauge reading)		0 - 0.0008 in. (0 - 0.02 mm)	0.0020 in. (0.05 mm)	See Inspection of camshaft on page 6-56.	
Cam lobe height	3TNV88C, 3TNV86CT, 4TNV88C, 4TNV86CT	1.5197 - 1.5276 in. (38.600 - 38.800 mm)	1.5098 in. (38.350 mm)		
	4TNV98C, 4TNV98CT	1.6707 - 1.6758 in. (42.435 - 42.565 mm)	1.6608 in. (42.185 mm)		
Shaft outside diameter/bearing inside diameter					
3TNV88C, 3TNV86CT, 4TNV88C, 4TNV86CT	Gear end	Bushing inside diameter	1.7713 - 1.7738 in. (44.990 - 45.055 mm)	1.7768 in. (45.130 mm)	See Inspection of camshaft on page 6-56.
		Camshaft outside diameter	1.7687 - 1.7697 in. (44.925 - 44.950 mm)	1.7673 in. (44.890 mm)	
		Oil clearance	0.0016 - 0.0051 in. (0.040 - 0.130 mm)	0.0094 in. (0.240 mm)	
	Intermediate	Bore inside diameter	1.7716 - 1.7726 in. (45.000 - 45.025 mm)	1.7756 in. (45.100 mm)	
		Camshaft outside diameter	1.7681 - 1.7691 in. (44.910 - 44.935 mm)	1.7667 in. (44.875 mm)	
		Oil clearance	0.0026 - 0.0045 in. (0.065 - 0.115 mm)	0.0089 in. (0.225 mm)	
	Flywheel end	Bore inside diameter	1.7716 - 1.7726 in. (45.000 - 45.025 mm)	1.7756 in. (45.100 mm)	
		Camshaft outside diameter	1.7687 - 1.7697 in. (44.925 - 44.950 mm)	1.7673 in. (44.890 mm)	
		Oil clearance	0.0020 - 0.0039 in. (0.050 - 0.100 mm)	0.0083 in. (0.210 mm)	
4TNV98C, 4TNV98CT	Gear end	Bushing inside diameter	1.9681 - 1.9707 in. (49.990 - 50.055 mm)	1.9736 in. (50.130 mm)	See Inspection of camshaft on page 6-56.
		Camshaft outside diameter	1.9655 - 1.9665 in. (49.925 - 49.950 mm)	1.7673 in. (49.890 mm)	
		Oil clearance	0.0016 - 0.0051 in. (0.040 - 0.130 mm)	0.0094 in. (0.240 mm)	
	Intermediate	Bore inside diameter	1.9685 - 1.9695 in. (50.000 - 50.025 mm)	1.9724 in. (50.100 mm)	
		Camshaft outside diameter	1.9650 - 1.9659 in. (49.910 - 49.935 mm)	1.9636 in. (49.875 mm)	
		Oil clearance	0.0026 - 0.0045 in. (0.065 - 0.115 mm)	0.0089 in. (0.225 mm)	
	Flywheel end	Bore inside diameter	1.9685 - 1.9695 in. (50.000 - 50.025 mm)	1.9724 in. (50.100 mm)	
		Camshaft outside diameter	1.9655 - 1.9665 in. (49.925 - 49.950 mm)	1.7673 in. (49.890 mm)	
		Oil clearance	0.0020 - 0.0039 in. (0.050 - 0.100 mm)	0.0083 in. (0.210 mm)	

Idler Gear Shaft and Bushing

Model	Inspection item		Standard	Limit	Reference page
3TNV88C, 3TNV86CT, 4TNV88C, 4TNV86CT	Idler gear A	Shaft outside diameter	1.8091 - 1.8100 in. (45.950 - 45.975 mm)	1.8071 in. (45.900 mm)	
		Bushing inside diameter	1.8110 - 1.8120 in. (46.000 - 46.025 mm)	1.8140 in. (46.075 mm)	
		Oil clearance	0.0010 - 0.0030 in. (0.025 - 0.075 mm)	0.0068 in. (0.175 mm)	
	Idler gear B	Shaft outside diameter	1.6909 - 1.6919 in. (42.950 - 42.975 mm)	1.6890 in. (42.900 mm)	
		Bushing inside diameter	1.6929 - 1.6939 in. (43.000 - 43.025 mm)	1.6959 in. (43.075 mm)	
		Oil clearance	0.0010 - 0.0030 in. (0.025 - 0.075 mm)	0.0068 in. (0.175 mm)	
4TNV98C, 4TNV98CT	Idler gear A	Shaft outside diameter	1.8091 - 1.8100 in. (45.950 - 45.975 mm)	1.8071 in. (45.900 mm)	
		Bushing inside diameter	1.8110 - 1.8120 in. (46.000 - 46.025 mm)	1.8140 in. (46.075 mm)	
		Oil clearance	0.0010 - 0.0030 in. (0.025 - 0.075 mm)	0.0068 in. (0.175 mm)	
	Idler gear B	Shaft outside diameter	1.8091 - 1.8100 in. (45.950 - 45.975 mm)	1.8071 in. (45.900 mm)	
		Bushing inside diameter	1.8110 - 1.8120 in. (46.000 - 46.025 mm)	1.8140 in. (46.075 mm)	
		Oil clearance	0.0010 - 0.0030 in. (0.025 - 0.075 mm)	0.0068 in. (0.175 mm)	

Timing Gear Backlash

Model	Inspection item	Standard	Limit	Reference page
All models	Crank gear, cam gear, idler gear, fuel injection pump gear and PTO gear	0.0031 - 0.0055 in. (0.08 - 0.14 mm)	0.0063 in. (0.16 mm)	<i>See Checking timing gear backlash on page 6-44.</i>

CRANKSHAFT AND PISTON SPECIFICATIONS

Crankshaft

Note: Check appropriate parts catalog for various sizes of replacement main bearing inserts.

Inspection item		Standard	Limit	Reference page	
Bend (1/2 the dial gauge reading)		–	0.0008 in. (0.02 mm)		
Connecting rod journals	3TNV88C, 3TNV86CT, 4TNV88C, 4TNV86CT	Journal outside diameter	1.8879 - 1.8883 in. (47.952 - 47.962 mm)	1.8859 in. (47.902 mm)	<i>See Inspection of crankshaft on page 6-55.</i>
		Bearing inside diameter	1.8898 - 1.8909 in. (48.000 - 48.026 mm)	–	
		Bearing insert thickness	0.0587 - 0.0591 in. (1.492 - 1.500 mm)	–	
		Oil clearance	0.0015 - 0.0029 in. (0.038 - 0.074 mm)	0.0059 in. (0.150 mm)	
	4TNV98C, 4TNV98CT	Journal outside diameter	2.2816 - 2.2820 in. (57.952 - 57.962 mm)	2.2796 in. (57.902 mm)	
		Bearing inside diameter	2.2835 - 2.2845 in. (58.000 - 58.026 mm)	–	
		Bearing insert thickness	0.0587 - 0.0591 in. (1.492 - 1.500 mm)	–	
		Oil clearance	0.0015 - 0.0029 in. (0.038 - 0.074 mm)	0.0059 in. (0.150 mm)	
Main bearing journal	3TNV88C, 3TNV86CT, 4TNV88C, 4TNV86CT	Journal outside diameter	1.9666 - 1.9670 in. (49.952 - 49.962 mm)	1.9646 in. (49.902 mm)	<i>See Inspection of crankshaft on page 6-55.</i>
		Bearing inside diameter	1.9685 - 1.9693 in. (50.000 - 50.020 mm)	–	
		Bearing insert thickness	0.0785 - 0.0791 in. (1.995 - 2.010 mm)	–	
		Oil clearance	0.0015 - 0.0027 in. (0.038 - 0.068 mm)	0.0059 in. (0.150 mm)	
	4TNV98C, 4TNV98CT	Journal outside diameter	2.5572 - 2.5576 in. (64.952 - 64.962 mm)	2.5552 in. (64.902 mm)	
		Bearing inside diameter	2.5590 - 2.5598 in. (65.000 - 65.020 mm)	–	
		Bearing insert thickness	0.0785 - 0.0791 in. (1.995 - 2.010 mm)	–	
		Oil clearance	0.0015 - 0.0027 in. (0.038 - 0.068 mm)	0.0059 in. (0.150 mm)	

Thrust Bearing

Inspection item	Standard	Limit	Reference page
Crankshaft end play - all models	0.0051 - 0.0091 in. (0.13 - 0.23 mm)	0.0110 in. (0.28 mm)	See Removal of crankshaft on page 6-50.

Piston

Inspection item		Standard	Limit	Reference page	
Piston outside diameter (Measure at 90° to the piston pin)	3TNV88C, 4TNV88C	3.4622 - 3.4634 in. (87.940 - 87.970 mm)	3.4604 in. (87.895 mm)	See Inspection of pistons, piston rings and wrist pin on page 6-52.	
	3TNV86CT, 4TNV86CT	3.3835 - 3.3846 in. (85.940 - 85.970 mm)	3.3817 in. (85.895 mm)		
	4TNV98C, 4TNV98CT	3.8559 - 3.8563 in. (97.940 - 97.950 mm)	3.8545 in. (97.905 mm)		
Piston diameter measure location (Upward from the bottom of the piston)	3TNV88C, 3TNV86CT, 4TNV88C, 4TNV86CT	0.9449 in. (24 mm)	—	See Inspection of pistons, piston rings and wrist pin on page 6-52.	
	4TNV98C, 4TNV98CT	0.8661 in. (22 mm)	—		
Piston pin	3TNV88C, 3TNV86CT, 4TNV88C, 4TNV86CT	Hole inside diameter	1.0236 - 1.0240 in. (26.000 - 26.009 mm)	1.0252 in. (26.039 mm)	See Inspection of pistons, piston rings and wrist pin on page 6-52.
		Pin outside diameter	1.0234 - 1.0236 in. (25.995 - 26.000 mm)	1.0222 in. (25.965 mm)	
		Oil clearance	0.0000 - 0.0006 in. (0.000 - 0.014 mm)	0.0029 in. (0.074 mm)	
	4TNV98C, 4TNV98CT	Hole inside diameter	1.1811 - 1.1815 in. (30.000 - 30.009 mm)	1.1826 in. (30.039 mm)	
		Pin outside diameter	1.1807 - 1.1811 in. (29.989 - 30.000 mm)	1.1795 in. (29.959 mm)	
		Oil clearance	0.0000 - 0.0008 in. (0.000 - 0.020 mm)	0.0031 in. (0.080 mm)	

Piston Ring

Model	Inspection item		Standard	Limit	Reference page
3TNV86CT, 4TNV86CT	Top ring	Ring groove width	0.0813 - 0.0819 in. (2.065 - 2.080 mm)	—	<i>See Inspection of pistons, piston rings and wrist pin on page 6-52.</i>
		Ring width	0.0776 - 0.0783 in. (1.970 - 1.990 mm)	0.0768 in. (1.950 mm)	
		Side clearance	0.0030 - 0.0043 in. (0.075 - 0.110 mm)	—	
		End gap	0.0079 - 0.0157 in. (0.200 - 0.400 mm)	0.0193 in. (0.490 mm)	
	Second ring	Ring groove width	0.0801 - 0.0807 in. (2.035 - 2.050 mm)	0.0846 in. (2.150 mm)	
		Ring width	0.0768 - 0.0776 in. (1.950 - 1.970 mm)	0.0760 in. (1.930 mm)	
		Side gap	0.0018 - 0.0039 in. (0.045 - 0.100 mm)	0.0079 in. (0.200 mm)	
		End gap	0.0118 - 0.0197 in. (0.30 - 0.50 mm)	0.0232 in. (0.590 mm)	
	Oil ring	Ring groove width	0.1581 - 0.1587 in. (4.015 - 4.030 mm)	0.1626 in. (4.130 mm)	
		Ring width	0.1563 - 0.1571 in. (3.970 - 3.990 mm)	0.01555 in. (3.950 mm)	
		Side clearance	0.0010 - 0.0024 in. (0.025 - 0.060 mm)	0.0071 in. (0.180 mm)	
		End gap	0.0079 - 0.0157 in. (0.200 - 0.400 mm)	0.0193 in. (0.490 mm)	

(Piston ring cont.)

Model	Inspection item		Standard	Limit	Reference page
3TNV88C, 4TNV88C	Top ring	Ring groove width	0.0807 - 0.0817 in. (2.050 - 2.075 mm)	—	<i>See Inspection of pistons, piston rings and wrist pin on page 6-52.</i>
		Ring width	0.0776 - 0.0783 in. (1.970 - 1.990 mm)	0.0768 in. (1.950 mm)	
		Side clearance	0.0028 - 0.0041 in. (0.070 - 0.105 mm)	—	
		End gap	0.0079 - 0.157 in. (0.200 - 0.400 mm)	0.0193 in. (0.490 mm)	
	Second ring	Ring groove width	0.0797 - 0.0803 in. (2.025 - 2.040 mm)	0.0843 in. (2.140 mm)	
		Ring width	0.0776 - 0.0783 in. (1.970 - 1.990 mm)	0.0768 in. (1.950 mm)	
		Side clearance	0.0014 - 0.0028 in. (0.035 - 0.070 mm)	0.0075 in. (0.190 mm)	
		End gap	0.0118 - 0.0197 in. (0.30 - 0.50 mm)	0.0193 in. (0.490 mm)	
	Oil ring	Ring groove width	0.1581 - 0.1587 in. (4.015 - 4.030 mm)	0.1626 in. (4.130 mm)	
		Ring width	0.1563 - 0.1571 in. (3.970 - 3.990 mm)	0.1555 in. (3.950 mm)	
		Side clearance	0.0010 - 0.0024 in. (0.025 - 0.060 mm)	0.0071 in. (0.180 mm)	
		End gap	0.0079 - 0.0157 in. (0.200 - 0.400 mm)	0.0193 in. (0.490 mm)	

(Piston ring cont.)

Model	Inspection item		Standard	Limit	Reference page
4TNV98C, 4TNV98CT	Top ring	Ring groove width	0.0803 - 0.0811 in. (2.040 - 2.060 mm)	—	<i>See Inspection of pistons, piston rings and wrist pin on page 6-52.</i>
		Ring width	0.0764 - 0.0772 in. (1.940 - 1.960 mm)	0.0756 in. (1.920 mm)	
		Side clearance	0.0031 - 0.0047 in. (0.080 - 0.120 mm)	—	
		End gap	0.0098 - 0.0177 in. (0.250 - 0.450 mm)	0.0213 in. (0.540 mm)	
	Second ring	Ring groove width	0.0819 - 0.0825 in. (2.080 - 2.095 mm)	0.0864 in. (2.195 mm)	
		Ring width	0.0776 - 0.0783 in. (1.970 - 1.990 mm)	0.0768 in. (1.950 mm)	
		Side clearance	0.0035 - 0.0049 in. (0.090 - 0.125 mm)	0.0096 in. (0.245 mm)	
		End gap	0.0177 - 0.0256 in. (0.450 - 0.650 mm)	0.0287 in. (0.730 mm)	
	Oil ring	Ring groove width	0.1187 - 0.1193 in. (3.015 - 3.030 mm)	0.1232 in. (3.130 mm)	
		Ring width	0.1169 - 0.1177 in. (2.970 - 2.990 mm)	0.1161 in. (2.950 mm)	
		Side clearance	0.0010 - 0.0024 in. (0.025 - 0.060 mm)	0.0071 in. (0.180 mm)	
		End gap	0.0098 - 0.0177 in. (0.250 - 0.450 mm)	0.0217 in. (0.550 mm)	

Connecting Rod

■ Connecting rod small end

Model	Inspection item	Standard	Limit	Reference page
3TNV88C, 3TNV86CT, 4TNV88C, 4TNV86CT	Wrist pin bushing inside diameter	1.0234 - 1.0251 in. (26.025 - 26.038 mm)	1.0263 in. (26.068 mm)	<i>See Inspection of connecting rod on page 6-54.</i>
	Wrist pin outside diameter	1.0234 - 1.0236 in. (25.995 - 26.000 mm)	1.0223 in. (25.967 mm)	
	Oil clearance	0.0010 - 0.0017 in. (0.025 - 0.043 mm)	0.0040 in. (0.101 mm)	
4TNV98C, 4TNC98CT	Wrist pin bushing inside diameter	1.1821 - 1.1826 in. (30.025 - 30.038 mm)	1.1838 in. (30.068 mm)	
	Wrist pin outside diameter	1.1806 - 1.1811 in. (29.987 - 30.000 mm)	1.1795 in. (29.959 mm)	
	Oil clearance	0.0010 - 0.0020 in. (0.025 - 0.51 mm)	0.0043 in. (0.109 mm)	

■ Connecting rod big end

Inspection item	Standard	Limit	Reference page
Side clearance - all models	0.0079 - 0.0157 in. (0.20 - 0.40 mm)	—	<i>See Inspection of connecting rod on page 6-54.</i>

Note: See Special Torque Chart on page 6-16 for other specifications.

Tappet

Model	Inspection item	Standard	Limit	Reference page
3TNV88C, 3TNV86CT, 4TNV88C, 4TNV86CT	Tappet bore (block) inside diameter	0.4724 - 0.4734 in. (12.000 - 12.025 mm)	0.4742 in. (12.045 mm)	<i>See Inspection of tappets on page 6-55.</i>
	Tappet stem outside diameter	0.4715 - 0.4720 in. (11.975 - 11.990 mm)	0.4707 in. (11.955 mm)	
	Oil clearance	0.0004 - 0.0020 in. (0.010 - 0.050 mm)	0.0035 in. (0.090 mm)	
4TNV98C, 4TNV98CT	Tappet bore (block) inside diameter	0.4724 - 0.4731 in. (12.000 - 12.018 mm)	0.4739 in. (12.038 mm)	
	Tappet stem outside diameter	0.4715 - 0.4720 in. (11.975 - 11.990 mm)	0.4707 in. (11.955 mm)	
	Oil clearance	0.0004 - 0.0017 in. (0.010 - 0.043 mm)	0.0033 in. (0.083 mm)	

CYLINDER BLOCK SPECIFICATIONS**Cylinder Block**

Inspection item	Model	Standard	Limit	Reference page
Cylinder inside diameter	3TNV88C - 4TNV88C	3.4646 - 3.4657 in. (88.000 - 88.030 mm)	3.4724 in. (88.200 mm)	<i>See Inspection of cylinder block on page 6-52.</i>
	3TNV86CT, 4TNV86CT	3.3858 - 3.3870 in. (86.000 - 86.030 mm)	3.3937 in. (86.200 mm)	
	4TNV98C, 4TNV98CT	3.8583 - 3.8594 in. (98.000 - 98.030 mm)	3.8634 in. (98.130 mm)	
Cylinder bore	Roundness	0.0004 in. (0.01 mm) or less	0.0012 in. (0.03 mm)	
	Taper			

SPECIAL TORQUE CHART

Torque for Bolts and Nuts

Component	Model	Thread diameter and pitch	Torque	Lubricating oil application (Thread portion and seat surface)
Cylinder head bolt	3TNV88C, 3TNV86CT, 4TNV88C, 4TNV86CT	M10 × 1.25 mm	63 - 67 ft·lb (85.3 - 91.1 N·m; 8.7 - 9.3 kgf·m)	Applied
	4TNV98C, 4TNV98CT	M11 × 1.25 mm	76 - 83 ft·lb (103.1 - 112.9 N·m; 10.5 - 11.5 kgf·m)	
Connecting rod bolt	3TNV88C, 3TNV86CT, 4TNV88C, 4TNV86CT	M9 × 1.0 mm	33 - 36 ft·lb (44.1 - 49.0 N·m; 4.5 - 5.0 kgf·m)	Applied
	4TNV98C, 4TNV98CT	M10 × 1.0 mm	40 - 43 ft·lb (53.9 - 58.8 N·m; 5.5 - 6.0 kgf·m)	
Flywheel bolt	3TNV88C, 3TNV86CT, 4TNV88C, 4TNV86CT	M10 × 1.25 mm	61 - 65 ft·lb (83.3 - 88.2 N·m; 8.5 - 9.0 kgf·m)	Applied
	4TNV98C, 4TNV98CT	M14 × 1.5 mm	137 - 152 ft·lb (186.2 - 205.8 N·m; 19 - 21 kgf·m)	
Main bearing cap bolt	3TNV88C, 3TNV86CT, 4TNV88C, 4TNV86CT	M12 × 1.5 mm	70.8 - 73.8 ft·lb (96.0 - 100 N·m; 9.8 - 10.2 kgf·m)	Applied
	4TNV98C, 4TNV98CT	M11 × 1.25 mm	80 - 87 ft·lb (108.1 - 117.9 N·m; 11.0 - 12.0 kgf·m)	
Crankshaft pulley bolt	3TNV88C, 3TNV86CT, 4TNV88C, 4TNV86CT	M14 × 1.5 mm	Cast metal (FC300) 62 - 69 ft·lb (83.3 - 93.1 N·m; 8.5 - 9.5 kgf·m)	Applied
			Steel metal (S45C) 83 - 91 ft·lb (112.7 - 122.7 N·m; 11.5 - 12.5 kgf·m)	
	4TNV98C, 4TNV98CT	M14 × 1.5 mm	80 - 94 ft·lb (107.9 - 127.5 N·m; 11.0 - 13.0 kgf·m)	

(Torque for bolts and nuts cont.)

Component	Model	Thread diameter and pitch	Torque	Lubricating oil application (Thread portion and seat surface)
Fuel injector bolt	3TNV88C, 3TNV86CT, 4TNV88C, 4TNV86CT	M8 × 1.25 mm	18 - 21 ft·lb (24.4 - 28.4 N·m; 2.5 - 2.9 kgf·m)	Not applied
	4TNV98C, 4TNV98CT	M8 × 1.25 mm	17 - 21 ft·lb (22.6 - 28.4 N·m; 2.3 - 2.9 kgf·m)	
Supply pump drive gear nut	3TNV88C, 3TNV86CT, 4TNV88C, 4TNV86CT	M18 × 1.5 mm	55 - 63 ft·lb (75 - 85 N·m; 7.7 - 8.7 kgf·m)	Not applied
	4TNV98C, 4TNV98CT	M18 × 1.5 mm	55 - 63 ft·lb (75 - 85 N·m; 7.7 - 8.7 kgf·m)	
High pressure fuel line nut	All models	M12 × 1.5 mm Common rail	21.7 - 25.3 ft·lb (29.4 - 34.3 N·m; 3.0 - 3.5 kgf·m)	Not applied
		M12 × 1.5 mm Injector	19.5 - 23.2 in·lb (26.5 - 34.3 N·m; 2.7 - 3.5 kgf·m)	
		M12 × 1.5 mm Supply pump	21.7 - 25.3 ft·lb (29.4 - 34.3 N·m; 3.0 - 3.5 kgf·m)	
Speed sensor, flywheel	All models	M6 × 1.0 mm	4.4 - 7.4 ft·lb (6.0 - 100 N·m; 0.6 - 1.0 kgf·m)	Not applied
Speed sensor, camshaft	All models	M6 × 1.0 mm	5.5 - 6.3 in·lb (7.5 - 8.5 N·m; 0.75 - 0.85 kgf·m)	Not applied
Pipe, EGR valve	3TNV88C, 3TNV86CT, 4TNV88C, 4TNV86CT	M8 × 1.25 mm	14.0 - 18.2 ft·lb (18.9 - 24.7 N·m; 1.9 - 2.5 kgf·m)	Not applied
	4TNV98C, 4TNV98CT	M10 × 1.5 mm	43.3 - 47.0 ft·lb (58.7 - 63.7 N·m; 6.0 - 6.5 kgf·m)	Not applied
Sensor, fresh air temp.	3TNV88C, 3TNV86CT, 4TNV88C, 4TNV86CT	M5 × 0.5 mm	3.0 - 3.7 in·lb (4.0 - 5.0 N·m; 0.41 - 0.51 kgf·m)	Not applied
	4TNV98C, 4TNV98CT	M6 × 1.0 mm	4.1 - 6.2 ft·lb (5.6 - 8.4 N·m; 0.57 - 0.86 kgf·m)	Not applied
Sensor, fresh air temp.	All models	M14 × 1.5 mm	8.1 - 12.5 ft·lb (11.0 - 17.0 N·m; 1.1 - 1.7 kgf·m)	Not applied

(Torque for bolts and nuts cont.)

Component	Model	Thread diameter and pitch	Torque	Lubricating oil application (Thread portion and seat surface)
Sensor, DPF temp.	All models	M12 × 1.25 mm	18.4 - 29.5 in·lb (25.0 - 40.0 N·m; 2.5 - 4.1 kgf·m)	Not applied
Sensor, differential press	All models	M6 × 1.0 mm	4.9 - 6.2 in·lb (6.6 - 8.4 N·m; 7.0 - 7.24 kgf·m)	Not applied
Sensor, differential press DPF	All models	M12 × 1.25 mm	33.2 - 40.5 in·lb (45.0 - 55.0 N·m; 4.6 - 5.6 kgf·m)	Not applied
Nut, valve cover	4TNV98C, 4TNV98CT	M8 × 1.5 mm	8.9 - 11.0 in·lb (12.0 - 15.0 N·m; 1.2 - 1.5 kgf·m)	Not applied
Glow plug	All models	M10 × 1.25 mm	133 - 177 in·lb (15 - 20 N·m; 1.53 - 2.04 kgf·m)	Not applied
Glow connector nut	All models	M4 × 0.7 mm	9 - 13 in·lb (1 - 1.5 N·m)	Not applied
Piston cooling nozzle banjo bolt	3TNV86CT, 4TNV86CT, 4TNV98CT	M8 × 1.25 mm	112.4 in·lb (12.7 - 16.7 N·m)	Not applied

Note: See Tightening Torques for Standard Bolts and Nuts on page 4-39 for standard hardware torque values.

SPECIAL SERVICE TOOLS

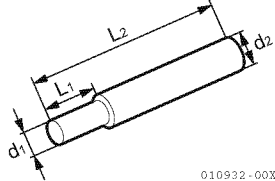
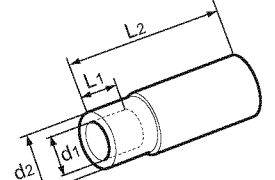
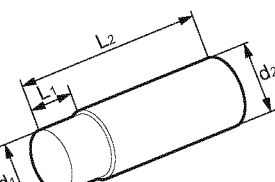
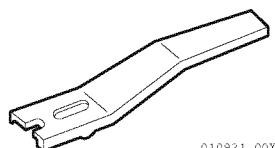
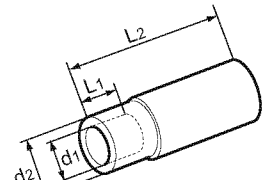
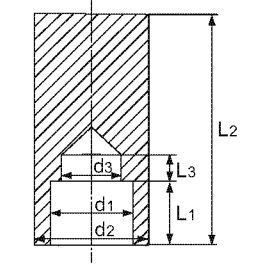

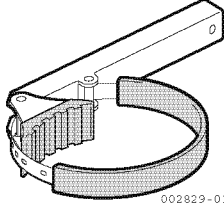
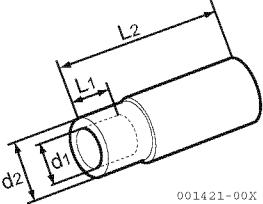
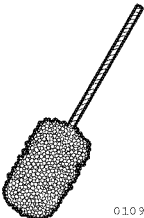
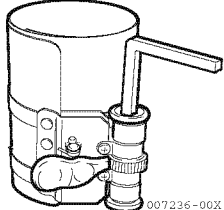
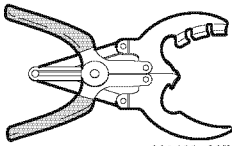
No.	Tool name	Applicable model and tool size					Illustration		
1	Valve guide tool (for removing valve guide)	Model	L1	L2	d1	d2	 <p>010932-00X</p>		
		All models	0.787 in. (20 mm)	2.953 in. (75 mm)	0.295 in. (7.5 mm)	0.433 in. (11 mm)			
		Locally manufactured							
2	Valve guide tool (for installing valve guide)	Model	L1	L2	d1	d2	 <p>001421-00X</p>		
		All models	0.591 in. (15 mm)	2.559 in. (65 mm)	0.551 in. (14 mm)	0.787 in. (20 mm)			
		Locally manufactured							
3	Connecting rod bushing replacer (for removal/ installation of connecting rod bushing)	Model	L1	L2	d1	d2	 <p>010933-00X</p>		
		3TNV88C, 3TNV86CT, 4TNV88C, 4TNV86CT	0.787 in. (20 mm)	3.937 in. (100 mm)	1.024 in. (26 mm)	1.142 in. (29 mm)			
		4TNV98C, 4TNV98CT	0.787 in. (20 mm)	3.937 in. (100 mm)	1.181 in. (30 mm)	1.299 in. (33 mm)			
		Locally manufactured							
4	Valve spring compressor (for removal/ installation of valve spring)	YANMAR Part No. 129100-92630					 <p>010931-00X</p>		
5	Stem seal installer (for installing valve stem seal)	Model	d1	d2	d3	L1	L2	L3	 <p>001421-00X</p>
		All models	0.638 in. (16.2 mm)	0.866 in. (22 mm)	0.531 in. (13.5 mm)	0.740 in. (18.8 mm)	2.559 in. (65 mm)	0.157 in. (4 mm)	
		Locally manufactured					 <p>001422-00X</p>		

No.	Tool name	Applicable model and tool size	Illustration															
6	Filter wrench (for removal/ installation of engine oil filter)	Available locally	 <p>002829-01X</p>															
7	Camshaft bushing tool (for extracting camshaft bushing)	<table border="1" data-bbox="323 477 1099 714"> <thead> <tr> <th>Model</th> <th>L1</th> <th>L2</th> <th>d1</th> <th>d2</th> </tr> </thead> <tbody> <tr> <td>3TNV88C, 3TNV86CT, 4TNV88, 4TNV86CT</td> <td>0.709 in. (18 mm)</td> <td>2.756 in. (70 mm)</td> <td>1.772 in. (45 mm)</td> <td>1.890 in. (48 mm)</td> </tr> <tr> <td>4TNV98C, 4TNV98CT</td> <td>0.709 in. (18 mm)</td> <td>2.756 in. (70 mm)</td> <td>1.968 in. (50 mm)</td> <td>2.087 in. (53 mm)</td> </tr> </tbody> </table> <p>Locally manufactured</p>	Model	L1	L2	d1	d2	3TNV88C, 3TNV86CT, 4TNV88, 4TNV86CT	0.709 in. (18 mm)	2.756 in. (70 mm)	1.772 in. (45 mm)	1.890 in. (48 mm)	4TNV98C, 4TNV98CT	0.709 in. (18 mm)	2.756 in. (70 mm)	1.968 in. (50 mm)	2.087 in. (53 mm)	 <p>001421-00X</p>
Model	L1	L2	d1	d2														
3TNV88C, 3TNV86CT, 4TNV88, 4TNV86CT	0.709 in. (18 mm)	2.756 in. (70 mm)	1.772 in. (45 mm)	1.890 in. (48 mm)														
4TNV98C, 4TNV98CT	0.709 in. (18 mm)	2.756 in. (70 mm)	1.968 in. (50 mm)	2.087 in. (53 mm)														
8	Flex-hone (for preparation of cylinder walls)	<table border="1" data-bbox="323 795 1099 1032"> <thead> <tr> <th>Model</th> <th>YANMAR Part No.</th> <th>Cylinder bore</th> </tr> </thead> <tbody> <tr> <td>3TNV88C, 3TNV86CT, 4TNV88, 4TNV86CT</td> <td>129400-92430</td> <td>3.268 - 3.740 in. (83 - 95 mm)</td> </tr> <tr> <td>4TNV98C, 4TNV98CT</td> <td>129400-92440</td> <td>3.504 - 3.976 in. (89 - 101 mm)</td> </tr> </tbody> </table>	Model	YANMAR Part No.	Cylinder bore	3TNV88C, 3TNV86CT, 4TNV88, 4TNV86CT	129400-92430	3.268 - 3.740 in. (83 - 95 mm)	4TNV98C, 4TNV98CT	129400-92440	3.504 - 3.976 in. (89 - 101 mm)	 <p>010930-00X</p>						
Model	YANMAR Part No.	Cylinder bore																
3TNV88C, 3TNV86CT, 4TNV88, 4TNV86CT	129400-92430	3.268 - 3.740 in. (83 - 95 mm)																
4TNV98C, 4TNV98CT	129400-92440	3.504 - 3.976 in. (89 - 101 mm)																
9	Piston ring compressor (for installing piston)	<p>YANMAR Part No. 95550-002476</p> <p>The piston insertion tool is applicable for 2.362 - 4.921 in. (60 - 125 mm) diameter pistons</p>	 <p>007236-00X</p>															
10	Piston ring expander (for removal/ installation of piston ring)	Available locally	 <p>001411-00X</p>															

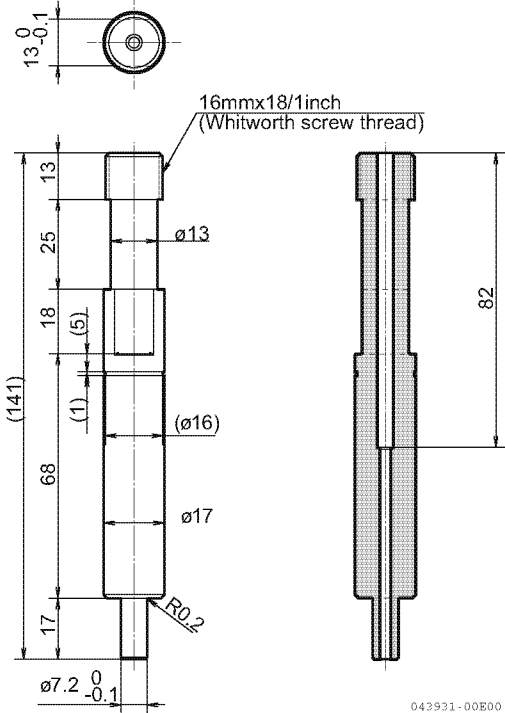
No.	Tool name	Applicable model and tool size	Illustration	Illustration
11	Crankshaft pulley installing tool (for taper pilot)	Locally manufactured (4TNV98C, 4TNV98CT series)		
12	Crankshaft pulley installing tool (for straight pilot)	Locally manufactured (4TNV98C, 4TNV98CT series)		
13	Pulley installing tool	3TNV88C, 3TNV86CT, 4TNV88C, 4TNV86CT		

No.	Tool name	Applicable model and tool size	Illustration
14	Compression gauge adapter (129A00-92950)	 <p>16mmx18/1inch (Whitworth screw thread)</p> <p>13⁰_{-0.1}</p> <p>13</p> <p>25</p> <p>18</p> <p>(5)</p> <p>(1)</p> <p>(141)</p> <p>68</p> <p>17</p> <p>ø13</p> <p>(ø16)</p> <p>ø17</p> <p>R0.2</p> <p>ø7.2⁰_{-0.1}</p> <p>82</p> <p>043931-00500</p>	

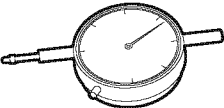
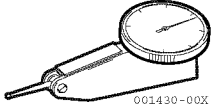
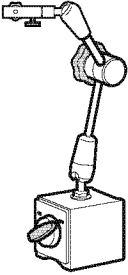
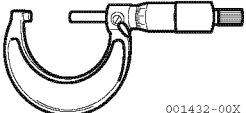
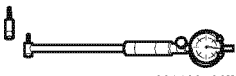
MEASURING INSTRUMENTS

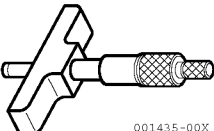
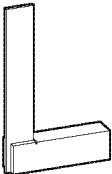
No.	Instrument name		Application	Illustration
1	Dial Indicator	Locally available	Measure shaft bend and end play.	 <p>001429-00X</p>
2	Test indicator	Locally available	Measurements of narrow or deep portions that cannot be measured by dial gauge.	 <p>001430-00X</p>
3	Magnetic stand	Locally available	For holding the dial gauge when measuring.	 <p>001431-00X</p>
4	Micrometer	Locally available	For measuring the outside diameters of crankshaft, pistons, piston pins, etc.	 <p>001432-00X</p>
5	Cylinder bore gauge	Locally available	For measuring the inside diameters of cylinder liners, bearing bores, etc.	 <p>001433-00X</p>
6	Calipers	Locally available	For measuring outside diameters, depth, thickness and width.	 <p>001434-00X</p>
7	Depth micrometer	Locally available	For measuring of valve recession.	 <p>001435-00X</p>
8	Square	Locally available	For measuring valve spring inclination and straightness of parts.	 <p>001436-00X</p>

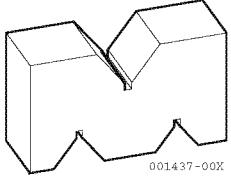
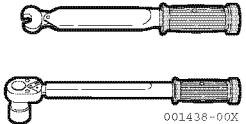
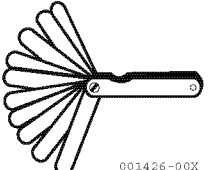
No.	Instrument name		Application	Illustration
9	V-block	Locally available	For measuring shaft bend.	
10	Torque wrench	Locally available	For tightening nuts and bolts to the specified torque.	
11	Feeler gauge	Locally available	For measuring piston ring gaps, piston ring clearance, and valve adjustment clearance.	

CYLINDER HEAD

Cylinder Head Components

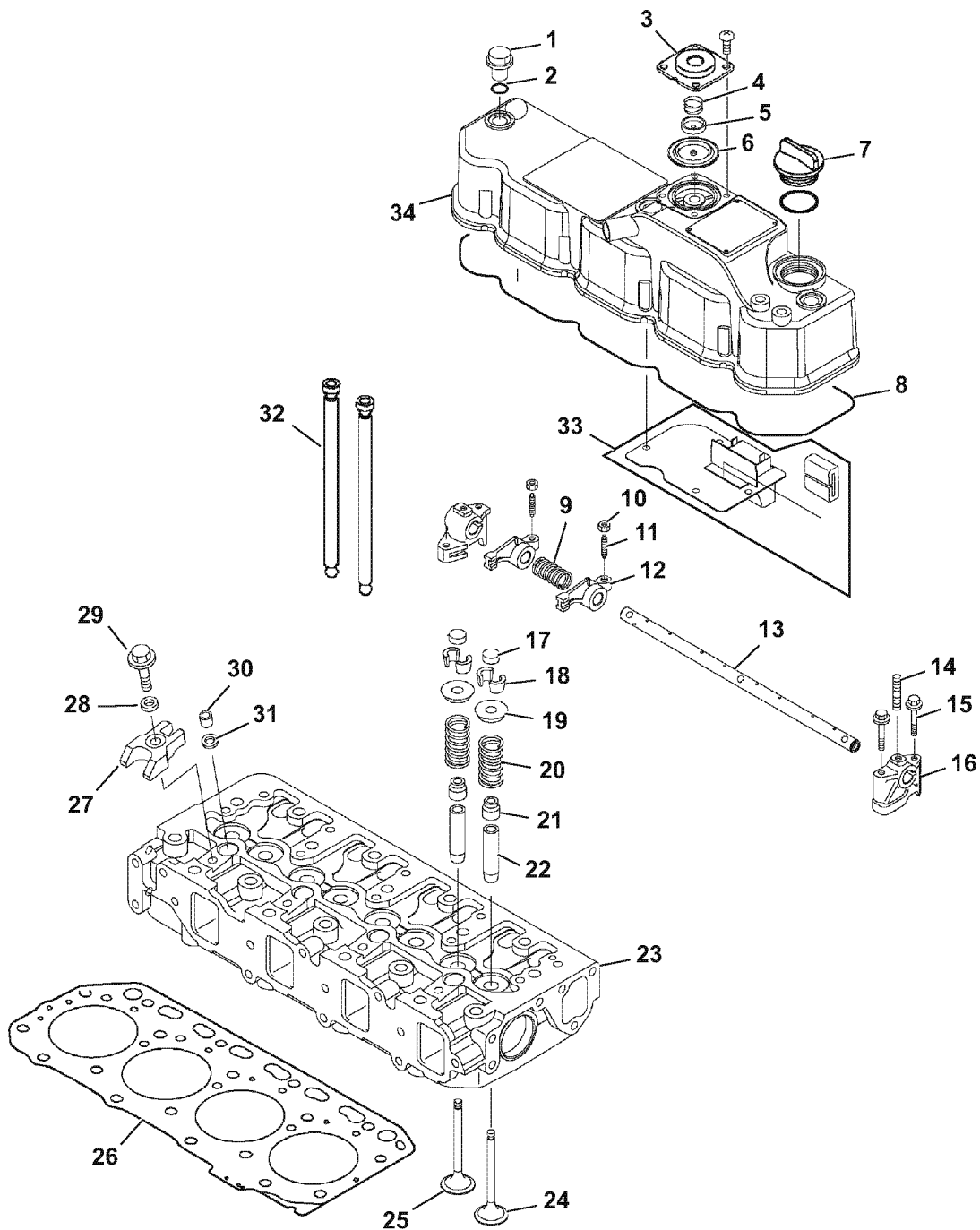

K0001919

Figure 6-1

- 1 – Valve cover nut
- 2 – Valve cover nut O-ring
- 3 – Crankcase breather cover
- 4 – Diaphragm spring
- 5 – Diaphragm plate
- 6 – Crankcase breather diaphragm
(non-turbocharged engines only)
- 7 – Oil fill cap
- 8 – Valve cover gasket
- 9 – Rocker arm shaft spring
- 10 – Valve adjusting screw lock nut
- 11 – Valve adjusting screw
- 12 – Rocker arm
- 13 – Rocker arm shaft
- 14 – Rocker arm shaft aligning stud
- 15 – Support bolt
- 16 – Rocker arm shaft support
- 17 – Valve cap
- 18 – Valve keepers
- 19 – Spring retainer
- 20 – Valve spring
- 21 – Valve stem seal
- 22 – Valve guide
- 23 – Cylinder head
- 24 – Intake valve
- 25 – Exhaust valve
- 26 – Cylinder head gasket
- 27 – Fuel injector retainer
- 28 – Washer
- 29 – Fuel injector retainer bolt
- 30 – Fuel injector nozzle protector
- 31 – Fuel injector nozzle seat
- 32 – Push rod
- 33 – Crankcase breather components
- 34 – Valve cover

Components of a Cylinder Head

Cylinder head with glow plugs applicable to all models.

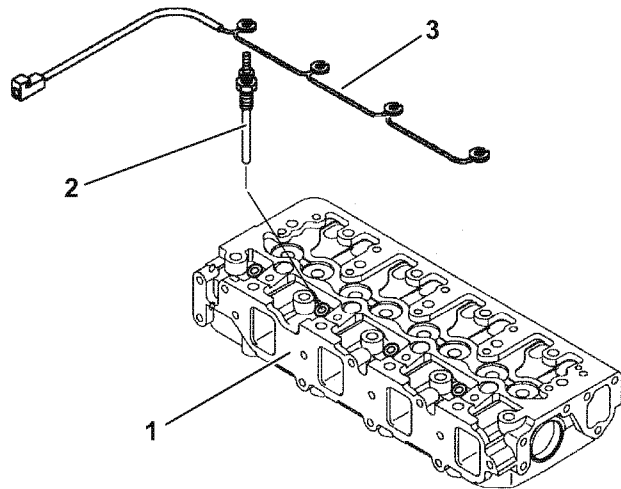

- 1 – Cylinder head
- 2 – Glow plug
- 3 – Harness, glow plug

Figure 6-2

Disassembly of Cylinder Head

Prepare a clean, flat working surface on a workbench large enough to accommodate the cylinder head assembly. Discard all gaskets, O-rings and seals. Use new gaskets, O-rings and seals on reassembly of the cylinder head.

1. Drain the coolant from the engine into a suitable container. *See Drain, flush and refill cooling system with new coolant on page 5-19.*

NOTICE

Identify all parts and their location using an appropriate method. It is important that all parts are returned to the same position during the reassembly process.

2. Disconnect the electrical wire from the glow plug, injector, intake throttle, EGR valve and sensors (**Figure 6-3, (1)**).

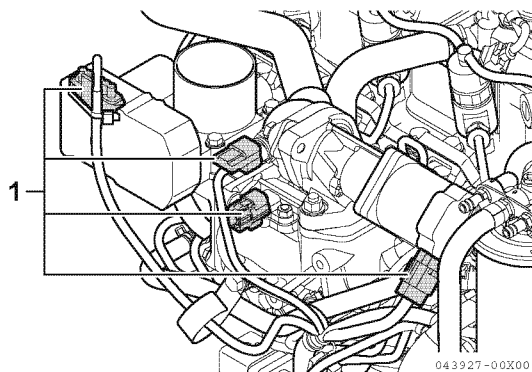

Figure 6-3

3. Disconnect the fuel pipes from the fuel filter, if the fuel filter is mounted on the intake manifold.
4. Remove the intake throttle, EGR valve and fuel filter on the intake manifold if required (discard the all gasket).
5. Remove the intake manifold bolts (**Figure 6-4, (1)**). Remove the intake manifold (**Figure 6-4, (2)**). Discard the intake manifold gasket (**Figure 6-4, (3)**).

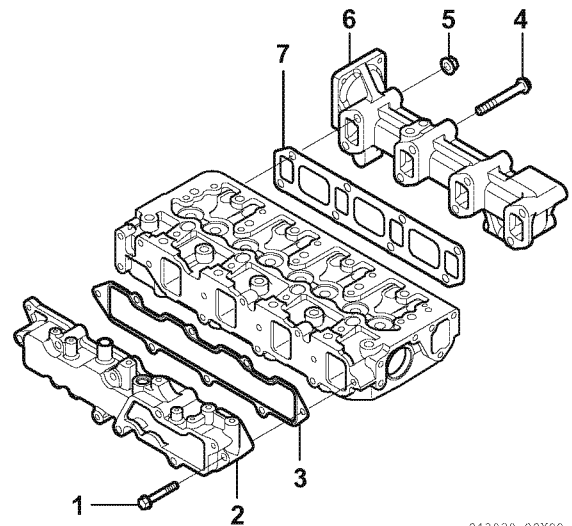

Figure 6-4

6. Disconnect the electrical wire from the diesel particulate filter if mounted.
7. Remove the diesel particulate filter from the engine (discard the all gasket).
8. Remove the exhaust manifold bolts (**Figure 6-4, (4)**) and nuts (**Figure 6-4, (5)**). Remove the exhaust manifold (**Figure 6-4, (6)**) and the exhaust manifold gasket (**Figure 6-4, (7)**).
9. Remove the coolant pump. *See Disassembly of Engine Coolant Pump on page 8-8.*
10. Remove the high-pressure lines and fuel injectors from the cylinder head. *See Removal of Injector on page 7-10.*

■ Removing the glow plugs

1. Remove the glow plug harness (Figure 6-5, (2)) from each glow plug (Figure 6-5, (1)).
2. Remove the glow plug from the cylinder head.

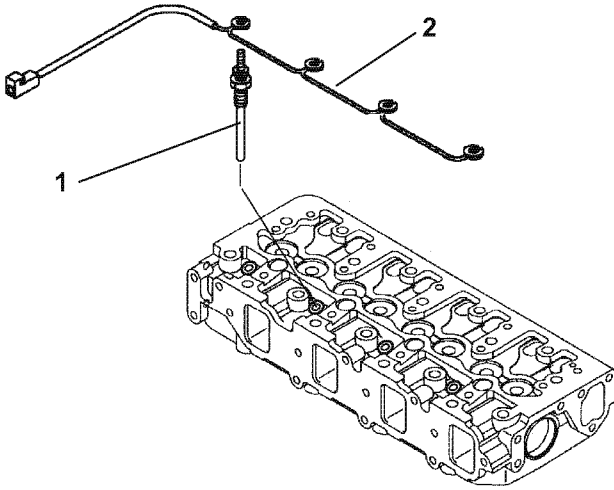

Figure 6-5

Note: Removing the cylinder head from the engine requires that the glow plugs be removed in advance.

Failure to remove the glow plugs in advance could result in damages to the glow plugs because their tips are protruding from the cylinder head combustion chamber surface.

■ Removal of valve cover

1. Disconnect the electrical wire from sensors on the valve cover.
2. Remove the valve cover nuts (Figure 6-6, (1)).
3. Remove the O-ring (Figure 6-6, (2)) on each valve cover nut.

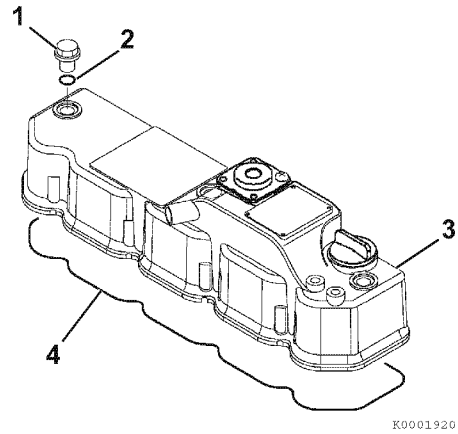

Figure 6-6

4. Remove the valve cover (Figure 6-6, (3)) and the valve cover gasket (Figure 6-6, (4)).

■ Removal of rocker arm assembly

1. Remove the bolts (Figure 6-7, (1)) that retain the rocker arm shaft supports.
2. Remove the rocker arm shaft assembly from the cylinder head.

Note: Identify the push rods so they can be reinstalled in their original locations.

3. Remove the push rods and identify for installation.

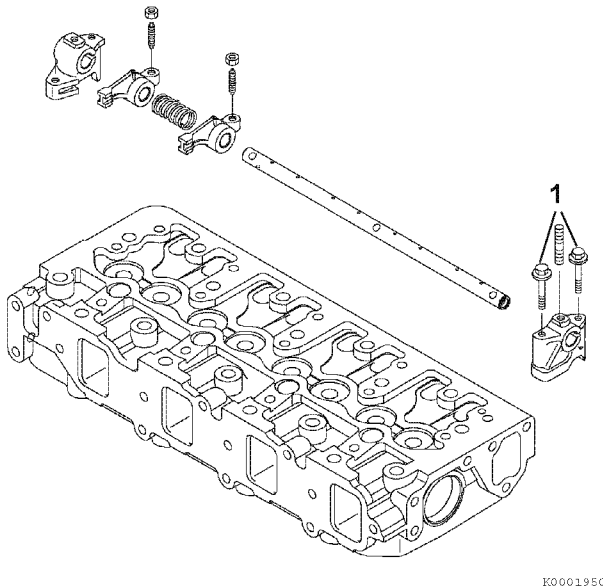

Figure 6-7

■ Disassembly of rocker arm assembly

1. Remove the rocker arm shaft alignment stud (Figure 6-8, (4)) from support (Figure 6-8, (5)).

Note: The rocker arm shaft fits tightly in the rocker arm supports. Clamp the support in a padded vise. Twist and pull out on the rocker arm shaft to remove. Reverse this process when you reinstall the rocker arm shaft into the supports.

2. Slide the rocker arm shaft (Figure 6-8, (3)) out of the rocker arm supports (Figure 6-8, (5)), springs (Figure 6-8, (1)), and rocker arms (Figure 6-8, (2)).

Note: Mark the rocker arms so they can be reinstalled with the original matching valve and pushrod.

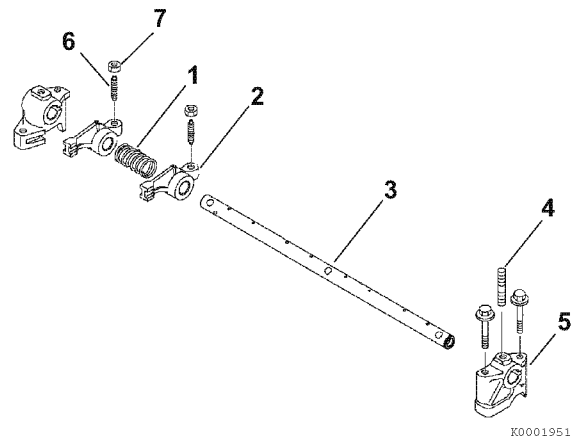
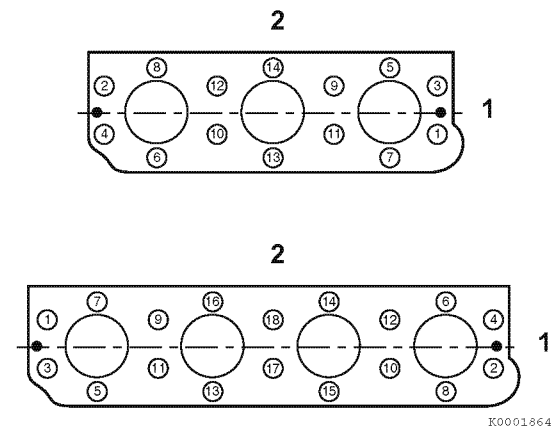

Figure 6-8

3. Remove the valve adjusting screw (Figure 6-8, (6)) and the lock nut (Figure 6-8, (7)) from the rocker arms.

■ Removal of cylinder head

1. Loosen the cylinder head bolts following the sequence shown in (Figure 6-9).



1 – Cooling fan end
2 – Camshaft side

Figure 6-9

2. Remove the cylinder head bolts (Figure 6-10, (1)).
3. Lift the cylinder head away from the cylinder block. Discard the cylinder head gasket (Figure 6-10, (2)). Position the cylinder head on the work bench to prevent damage to the combustion surface.

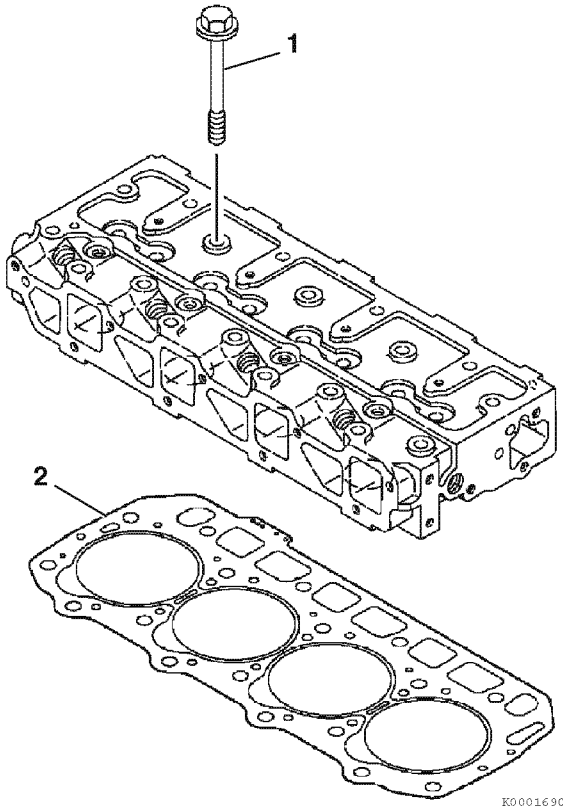

Figure 6-10

■ Removal of intake/exhaust valves

1. Place the cylinder head on the work bench with the combustion side down.
2. Remove the valve cap (Figure 6-12, (1)) and keep with the valve it was installed on.
3. Using the valve spring compressor tool, compress one of the valve springs (Figure 6-11).

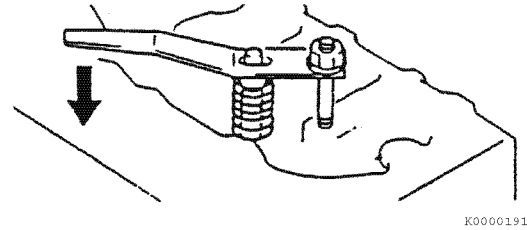

Figure 6-11

4. Remove the valve keepers (Figure 6-12, (2)).
5. Slowly release the tension on the valve spring.
6. Remove the spring retainer (Figure 6-12, (3)) and valve spring (Figure 6-12, (4)).

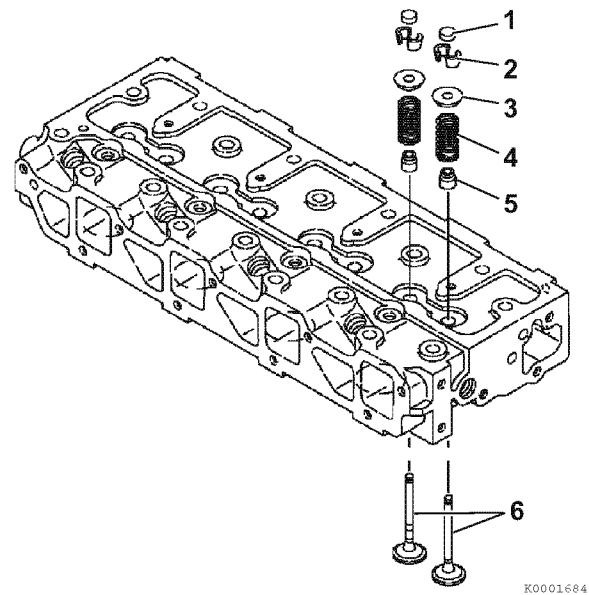

Figure 6-12

7. Repeat the procedure with all remaining valves.

Note: If the valves are to be reused, identify them so they can be installed in their original location.

8. Turn the cylinder head so the exhaust port side faces down. Remove the intake and exhaust valves (**Figure 6-12, (6)**) from the cylinder head.
9. Remove the valve stem seals (**Figure 6-12, (5)**).

■ Removal of valve guides

Note: Removal of the valve guides should be postponed until inspection and measurement procedures have been performed. See Inspection of valve guides on page 6-33.

1. If the valve guides were not within specifications, use a drift pin and hammer to drive the valve guides (**Figure 6-13, (1)**) out of the cylinder head.

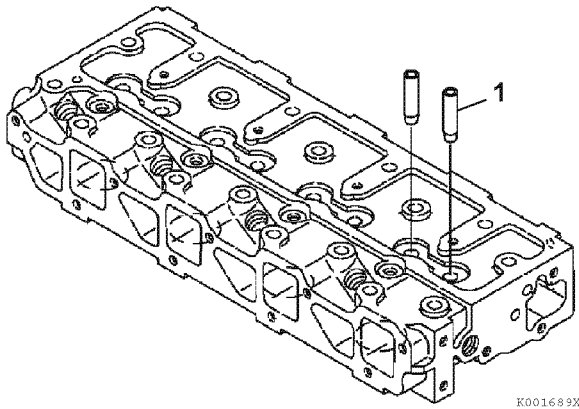
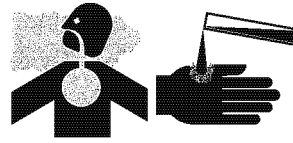

Figure 6-13

Cleaning of Cylinder Head Components

⚠ WARNING

Fume/Burn Hazard!



- Always read and follow safety related precautions found on containers of hazardous substances like parts cleaners, primers, sealants and sealant removers.

- Failure to comply could result in death or serious injury.

Thoroughly clean all components using a non-metallic brush and an appropriate solvent. Each part must be free of carbon, metal filings and other debris.

Inspection of Cylinder Head Components

Visually inspect the parts. Replace any parts that are obviously discolored, heavily pitted or otherwise damaged. Discard any parts that do not meet its specified limit.

NOTICE

Any part which is found defective as a result of inspection or any part whose measured value does not satisfy the standard or limit must be replaced.

NOTICE

Any part determined to not meet the service standard or limit before the next service, as determined from the state of current rate of wear, should be replaced even though the part currently meets the service standard limit.

■ Inspection of push rods

Push rod bend

Determine if the bend of the push rods are within the specified limit.

1. Place the push rods on a flat inspection block or layout bed.
2. Roll the push rods until a gap can be observed between a portion of the push rod and the surface of the block or layout bed.
3. Use a feeler gauge to measure the gap (**Figure 6-14**). See *Push Rod* on page 6-6 for the service limit.

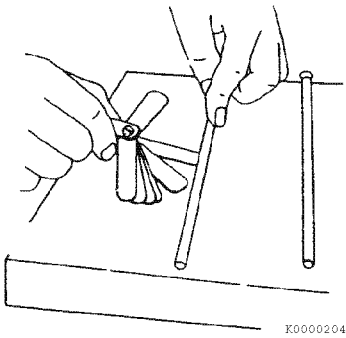

Figure 6-14

■ Inspection of rocker arm assembly

Rocker arm shaft hole diameter

Use a test indicator and micrometer to determine if the inside diameter of all the rocker arm support brackets and the rocker arms (**Figure 6-15**) are within the specified limits. See *Rocker Arm and Shaft* on page 6-6 for the service limit.

Inspect the contact areas (**Figure 6-15, (1)**) for excessive wear or damage.

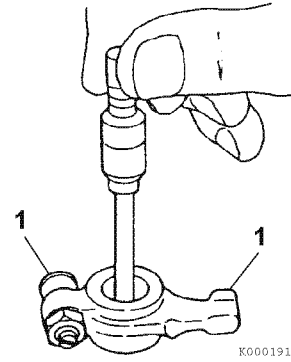

Figure 6-15

Rocker arm shaft outside diameter

Use a micrometer to measure the rocker arm shaft diameter. Measure at each rocker arm location in two directions 90° apart (**Figure 6-16**). See *Rocker Arm and Shaft* on page 6-6 for the service limit.

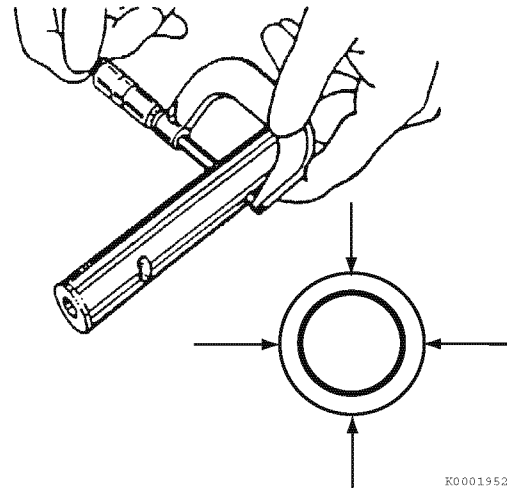

Figure 6-16

■ Inspection of valve guides

Visually inspect the valve guides for distortions, scoring or other damage.

Note: Measure the valve guides while they are installed in the cylinder head.

Use a telescoping gauge and micrometer to measure the inside diameter at each end of the valve guide. Measure in three places and 90° apart (**Figure 6-17**). See *Intake/Exhaust Valve and Guide* on page 6-5 for the service limit. Replace valve guides if not within specification.

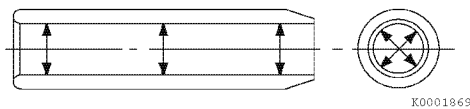

Figure 6-17

■ Inspection of cylinder head

Cylinder head distortion

Place the cylinder head flat and inverted (combustion side up) on the bench. Use a straight edge and a feeler gauge to measure cylinder head distortion (**Figure 6-18**). Measure diagonally and along each side. See *Cylinder Head* on page 6-4 for the service limit.

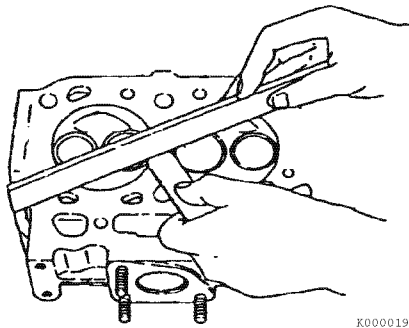

Figure 6-18

If distortion exceeds the service limit, resurface or replace the cylinder head. Remove only enough material to make the cylinder head flat, but do not remove more than 0.008 in. (0.20 mm).

■ Inspection of intake and exhaust valves

Visually inspect the intake and exhaust valves. Replace any valves that are obviously discolored, heavily pitted or otherwise damaged.

Valve stem diameter

Use a micrometer to measure the valve stem diameter. Measure the valve stem near the combustion end and near the opposite end (**Figure 6-19, (1)**). See *Intake/Exhaust Valve and Guide* on page 6-5 for the service limit.

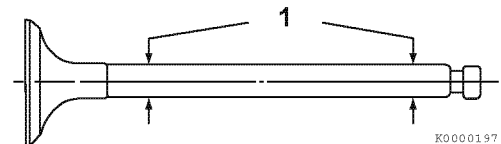

Figure 6-19

Valve stem bend

Place the valve stem on a flat inspection block or layout bed. Roll the valve until a gap can be observed between a portion of the valve stem and the surface of the block or bed. Use a feeler gauge to measure the gap (**Figure 6-20**). See *Intake/Exhaust Valve and Guide* on page 6-5 for the service limit.

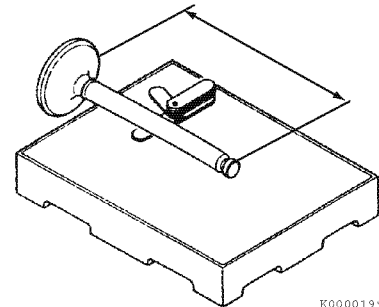

Figure 6-20

Valve recession

Note: The valve guides must be installed to perform this check.

Insert the valves into their original locations and press them down until they are fully seated. Use a depth micrometer (**Figure 6-21**) to measure the difference between the cylinder head gasket surface and the combustion surface of each exhaust and intake valve (**Figure 6-22**). See *Cylinder Head on page 6-4 for the service limit*.

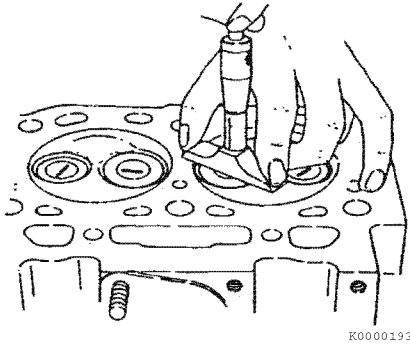

Figure 6-21

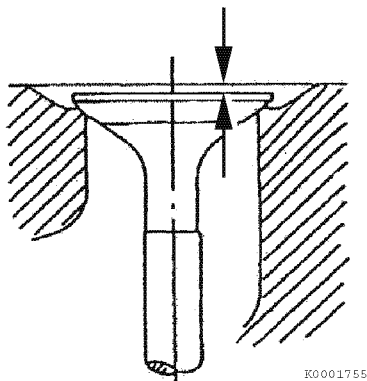

Figure 6-22

Valve face and valve seat

Always check the clearance between the valve and valve guide before grinding or lapping the valve seats. See *Intake/Exhaust Valve and Guide on page 6-5 for the service limit*. If the clearance exceeds the limit, replace the valve and/or valve guide to bring the clearance within the limit.

Roughness or burrs will cause poor seating of a valve. Visually inspect the seating surfaces of each valve and valve seat to determine if lapping or grinding is needed.

Visually inspect all valve faces and valve seats for pitting, distortion, cracking, or evidence of overheating. Usually the valves and the valve seats can be lapped or ground to return them to serviceable condition. Severely worn or damaged components will require replacement.

Coat the valve seat with a thin coat of bluing compound. Install the valve and rotate it to distribute bluing onto the valve face. The contact pattern should be approximately centered on the valve face (**Figure 6-23, (1)**) and even in width.

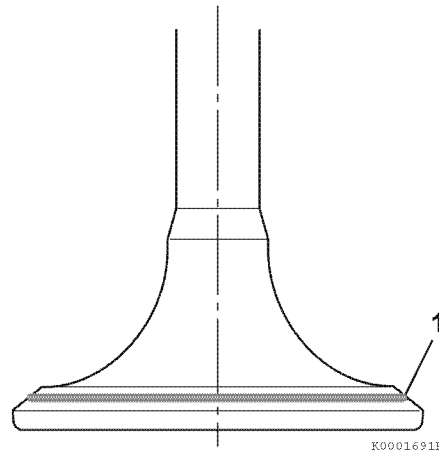

Figure 6-23

Also visually inspect the valve seat for even contact.

Light cutting can be performed by the use of a hand-operated cutter (**Figure 6-24, (3)**).

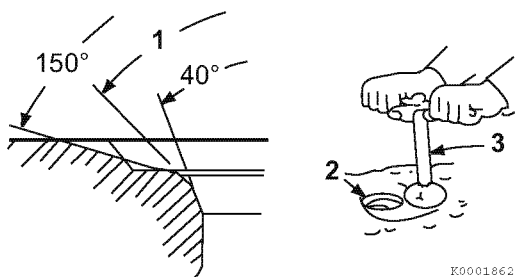

Figure 6-24

The valve seat diameter can be adjusted by top-grinding with a 150° stone to make the seat diameter smaller, and bottom-grinding using a 40° stone to make the seat diameter larger. Once the seat location has been corrected, grind and lap the seat angle (**Figure 6-24, (1)**) to specification. See *Cylinder Head* on page 6-4 for specifications.

Grind the valve face and/or valve seat only enough to return them to serviceable condition. Grinding is needed if the valve and the valve seat do not contact correctly. Check the recession after grinding.

If the valve or seat require grinding, lap the valve after grinding. Lap the valve face to the valve seat using a mixture of valve lapping compound and engine oil.

Be sure to thoroughly wash all parts to remove all grinding powder or compound.

■ Inspection of valve springs

Inspect the valve springs. If damage or corrosion is seen, or if measurements exceed the specified limits, replace the springs.

Fractures

Check for fractures on the inside and outside portions of the springs. If the valve spring is fractured, replace the valve spring.

Corrosion

Check for corrosion of the spring material caused by oxidation.

Squareness

Use a flat surface and a square to check each spring for squareness (**Figure 6-25**). See *Valve Spring* on page 6-6 for the service limit.

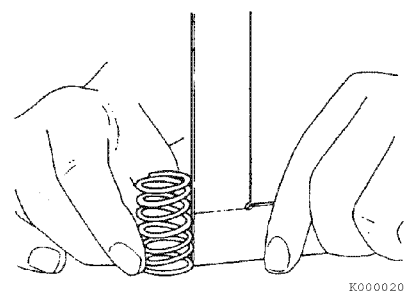

Figure 6-25

Free length

Use a caliper to measure the length of the spring (**Figure 6-26**). See *Valve Spring* on page 6-6 for the service limit.

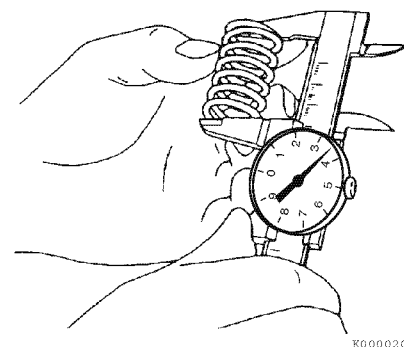

Figure 6-26

Reassembly of Cylinder Head

Use new gaskets, O-rings and seals for the reassembly of the cylinder head.

NOTICE

Liberalily oil all components during reassembly to prevent premature wear or damage.

■ Reassembly of valve guides

1. The valve guides are installed into the cylinder head with an extremely tight press fit. Before installing the valve guides, place the valve guides in a freezer for at least twenty minutes. This will cause the valve guides to contract, making it easier to install the valve guides into place.
2. Immediately after removing the valve guides from the freezer, insert the valve guides (Figure 6-27, (1)) in their proper positions.

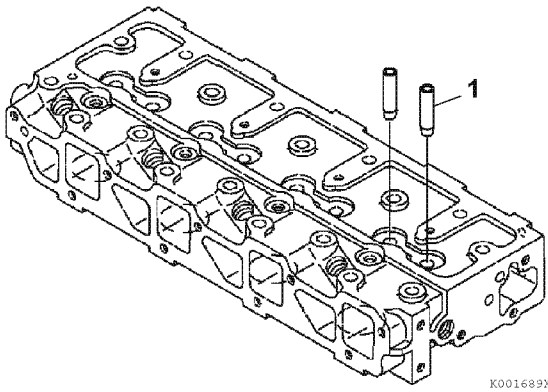

Figure 6-27

3. Finish installing the valve guides (Figure 6-28, (1)) into the cylinder head to the proper height (Figure 6-28, (3)) using the valve guide installation tool (Figure 6-28, (2)). See *Valve Guide Projection specification starting on page 6-5.*

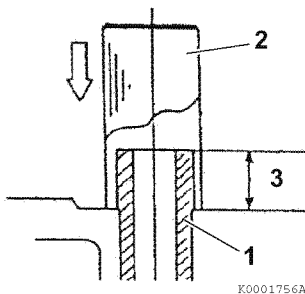

Figure 6-28

■ Reassembly of intake and exhaust valves

NOTICE

Always install new valve stem seals.

The exhaust valve stem seals are different than the intake valve stem seals and can be identified by either the paint marks on the outside of the seals or by the color of the seal spring (Figure 6-30, (4)). Ensure they are installed in the correct locations.

Engine model	Marking	
	Intake	Exhaust
All models	None	White (Paint on outside of seal)

1. Oil the lip of the valve stem seal (Figure 6-29, (2)). Using the valve stem seal installation tool (Figure 6-29, (1)), install a new valve stem seal on each of the valve guides (Figure 6-29, (3)).

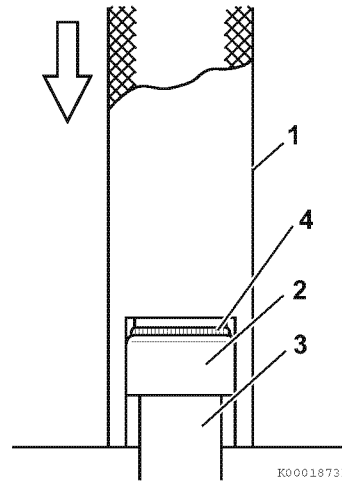

Figure 6-29

2. Measure the distance (Figure 6-30, (1)) from the cylinder head to valve stem seal to ensure proper clearance (Figure 6-30, (2)) between the guide and the seal. See *Valve Stem Seal Projection specification on page 6-6.*

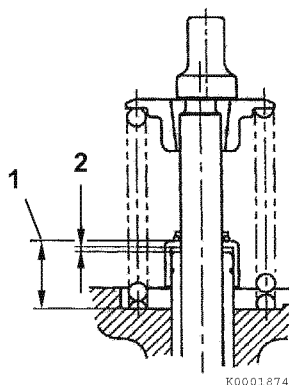

Figure 6-30

3. Place the cylinder head assembly on its exhaust port side.
4. Place all the valves (Figure 6-31, (6)) in their proper location in the cylinder head.

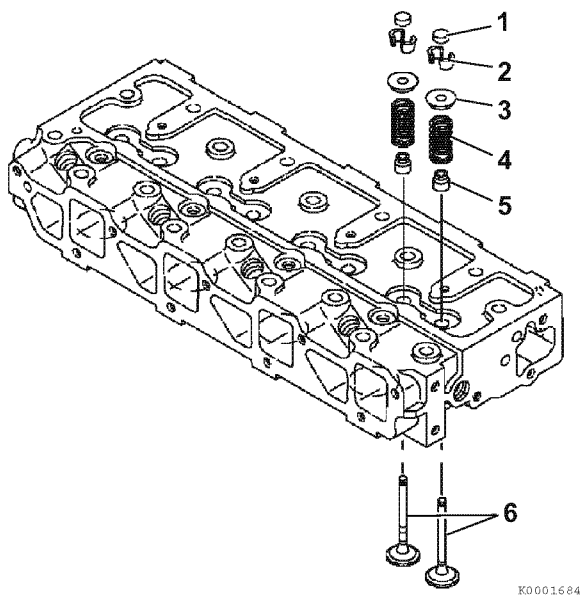

Figure 6-31

5. Place the cylinder head on the workbench with the combustion side down to install the valve springs. Install the valve spring (Figure 6-31, (4)) and the spring retainer (Figure 6-31, (5)).
6. Using the valve spring compressor tool, compress the valve spring.

7. Insert the valve keepers (Figure 6-31, (2)) and slowly release the tension on the valve spring. Install the valve cap (Figure 6-31, (1)). Repeat the steps on all the remaining valves.

■ Reassembly of cylinder head

1. Carefully clean both the combustion surface of the cylinder head and the top surface of the cylinder block. Then place a new cylinder head gasket (Figure 6-32, (2)) on the cylinder block.
2. Position the cylinder head on the cylinder head gasket.

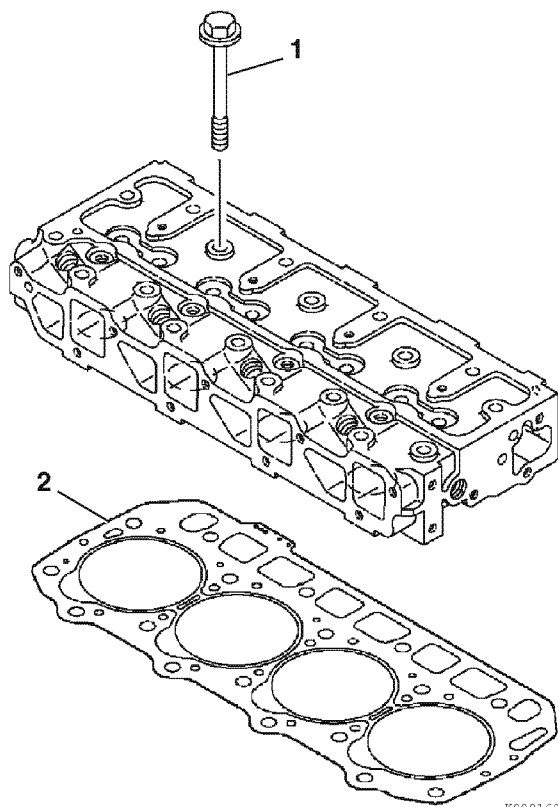
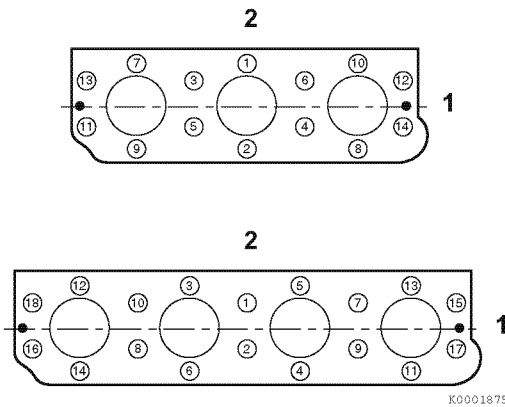

Figure 6-32

- Lightly oil the threads of the cylinder head bolts (Figure 6-32, (1)). Tighten the bolts to the specified torque in two steps as shown in the chart below. Tighten in the sequence shown in (Figure 6-33). See *Special Torque Chart* on page 6-16 for specification.

First step	1/2 of final torque
Second step	Final torque

- Insert the push rods in their respective positions.



1 – Fan end
2 – Camshaft side

Figure 6-33

■ Reassembly of rocker arm reassembly

NOTICE

Ensure the lubrication holes (Figure 6-34, (1)) in the rocker arm shaft are oriented correctly with respect to the rocker arms (Figure 6-34, (2)).

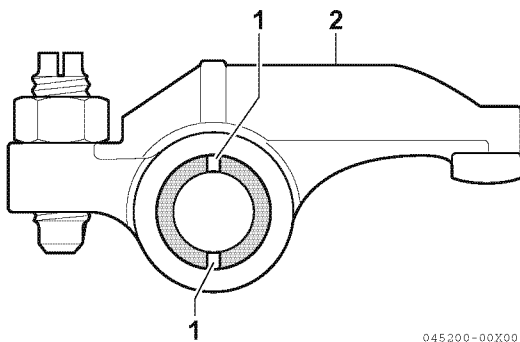

Figure 6-34

- Lubricate the rocker arm shaft. Slide the rocker arm supports (Figure 6-35, (5)), springs (Figure 6-35, (1)) and rocker arms (Figure 6-35, (2)) onto the shaft.

Note:

- The rocker arm shaft fits tightly in the rocker arm supports. Clamp the support in a padded vise. Twist and push on the rocker arm shaft to reinstall.
- To properly align the rocker arm shaft with the rocker arm shaft supports, first reinstall a rocker arm support (Figure 6-35, (5)) having a hole for the shaft alignment stud (Figure 6-35, (4)). Align the hole in the rocker arm shaft and the hole in the rocker arm support. Reinstall the alignment stud.

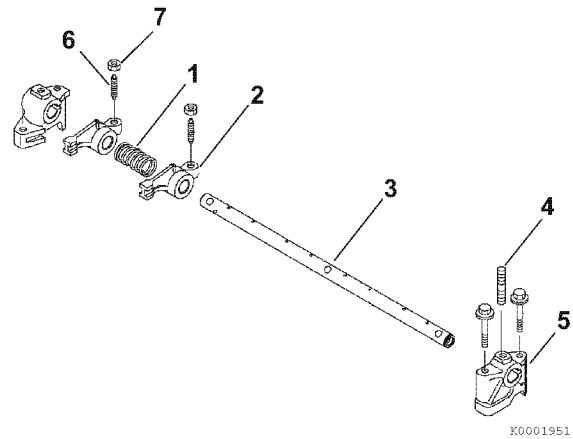

Figure 6-35

Note: Figure 6-35 shows components for one cylinder. Components for all remaining cylinders are assembled in the same order.

- Place the rocker arm shaft assembly onto the cylinder head.
- If removed, reinstall the valve adjusting screws (Figure 6-35, (6)) and the lock the nuts (Figure 6-35, (7)).
- Align the push rods with their respective rocker arms.
- Reinstall and tighten the rocker arm shaft retaining bolts to the specified torque.
- Tighten the rocker arm shaft alignment studs.
- Adjust the valve clearance. See *Measuring and Adjusting Valve Clearance* on page 6-40.

■ Reassembly of the valve cover

1. Lightly grease a new valve cover gasket (Figure 6-36, (4)). Place the gasket in the groove of the valve cover (Figure 6-36, (3)).
2. Place the valve cover on the cylinder head.
3. Be sure new O-rings (Figure 6-36, (2)) are installed on the valve cover nuts. Reinstall and tighten the valve cover nuts (Figure 6-36, (1)).
4. Reinstall the exhaust manifold using a new gasket. Tighten the bolts to the specified torque.

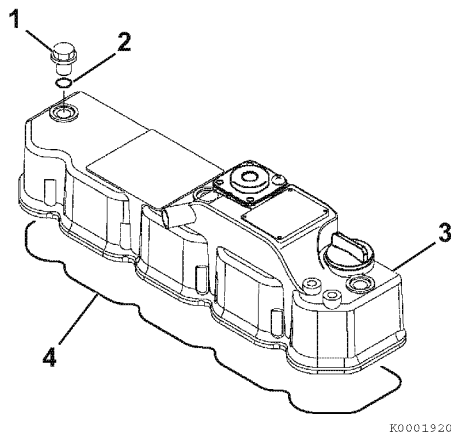

Figure 6-36

5. Reinstall the intake manifold using a new gasket. Tighten the bolts to the specified torque.
6. Install each glow plug (Figure 6-37, (1)), and tighten it with the specified torque. Install each electrical harness (Figure 6-37, (1)), and tighten it with the specified torque.

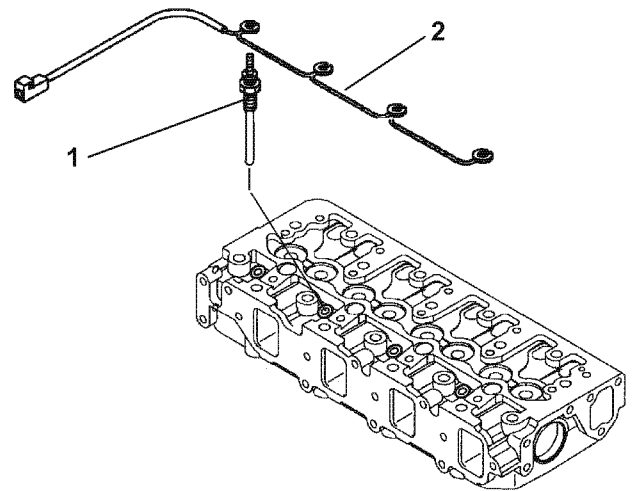

Figure 6-37

7. Reinstall the fuel injectors. See *Reassembly of injector* on page 7-10.
8. Reinstall the high pressure and the return fuel injection lines. See *Removal of Common Rail* on page 7-8
9. Reinstall the engine coolant pump. See *Reassembly of Engine Coolant Pump* on page 8-10.

CAUTION

For high-pressure pipe, use a new one. If you reuse it, the displacement of the working face may occur, causing the fuel leaks.

10. Reinstall the coolant hoses on the cold start device on the fuel injection pump.
11. Reinstall the alternator. See *Installation of Alternator* on page 12-14.

MEASURING AND ADJUSTING VALVE CLEARANCE

Measure and adjust while the engine is cold.

Note:

- The No. 1 piston position is on the flywheel end of the engine, opposite the radiator. The firing order is 1-3-2 for 3-cylinder engines and 1-3-4-2 for 4-cylinder engines.
- 3-cylinder engines fire every 240° of crankshaft rotation.
- 4-cylinder engines fire every 180° of crankshaft rotation.
- Valve clearance of both the intake and exhaust valves can be checked with the piston for that cylinder at top dead center (TDC) of the compression stroke. When a piston is at TDC of the compression stroke, both rocker arms will be loose and the cylinder TDC mark on the flywheel will be visible in the timing port of the flywheel housing.

- If there is no valve clearance, and the cylinder is at TDC of the compression stroke, extreme wear, or damage to the cylinder head or valves may be possible.
- If adjusting each cylinder individually, the cylinder to be adjusted first does not have to be the No. 1 cylinder. Select and adjust the cylinder where the piston is nearest to the top dead center after turning. Make adjustment for the remaining cylinders in the order of firing by turning the crankshaft each time.
- To decrease the number of rotations required to check all cylinders, other cylinders can also be checked as indicated in the chart below.

Example: On a 3-cylinder engine, with the No. 1 piston at TDC on the compression stroke (both valves closed), the valves indicated on the top line of the chart can be adjusted without rotating the crankshaft. To adjust the remaining two valves, rotate the crankshaft until the No. 1 piston is at TDC on the exhaust stroke (exhaust valve only open).

■ 3-cylinder engines

Cylinder No.	1		2		3	
	Intake	Exhaust	Intake	Exhaust	Intake	Exhaust
No. 1 cylinder at TDC compression	•	•	•			•
No. 1 cylinder at TDC exhaust				•	•	

■ 4-cylinder engines

Cylinder No.	1		2		3		4	
	Intake	Exhaust	Intake	Exhaust	Intake	Exhaust	Intake	Exhaust
No. 1 cylinder at TDC compression	•	•	•			•		
No. 4 cylinder at TDC compression				•	•		•	•

1. Remove the valve cover. See *Removal of valve cover on page 6-28.*

Note: If adjusting each cylinder individually, the cylinder to be adjusted first does not have to be the No. 1 cylinder. Select and adjust the cylinder where the piston is nearest to the top dead center after turning, and make adjustment for other cylinders in the order of firing by turning the crankshaft.

2. Rotate the crankshaft clockwise as seen from the coolant pump end, to bring No. 1 piston to TDC on the compression stroke while watching the rocker arm motion and timing grid on the flywheel. (Position where both the intake and exhaust valves are closed.)
3. Insert a feeler gauge (Figure 6-38, (1)) between the rocker arm and valve cap, and record the measured valve clearance. (Use the data for estimating the wear.)

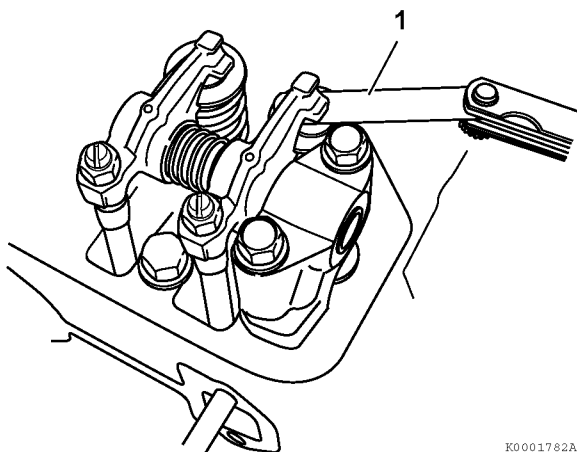

Figure 6-38

4. If adjustment is required, proceed to the next step.
5. Loosen the valve adjusting screw lock nut (Figure 6-39, (1)) and valve adjusting screw (Figure 6-39, (2)) on the rocker arm and check the valve for inclination of the valve cap, entrance of dirt, or wear.

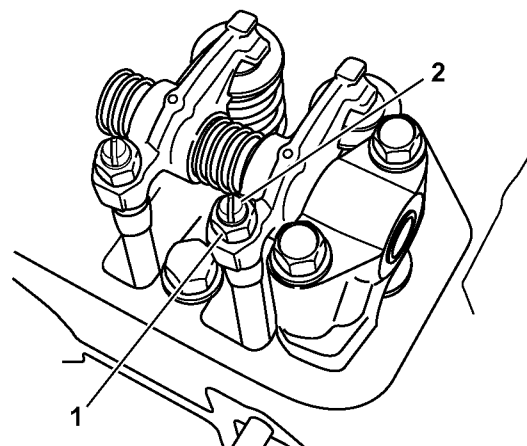

Figure 6-39

6. Insert a feeler gauge of the correct thickness (Figure 6-40, (1)) (see *Adjustment Specifications on page 6-4*) between the rocker arm and valve cap. Turn the valve adjustment screw to adjust the valve clearance so there is a slight “drag” on the feeler gauge when sliding it between the rocker arm and the valve cap. Hold the adjusting screw while tightening the valve adjusting screw lock nut (Figure 6-39, (1)). Recheck the clearance.

Note: There is a tendency for the clearance to decrease slightly when the lock nut is tightened. It is suggested that you make the initial clearance adjustment slightly on the “loose” side before tightening the lock nut.

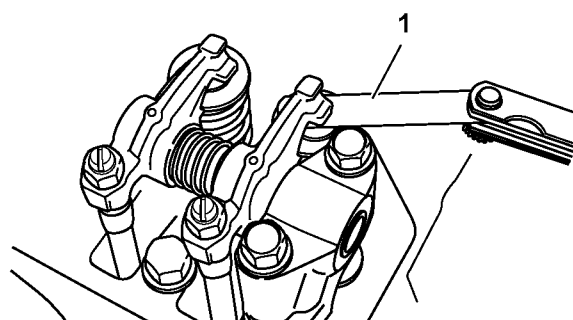
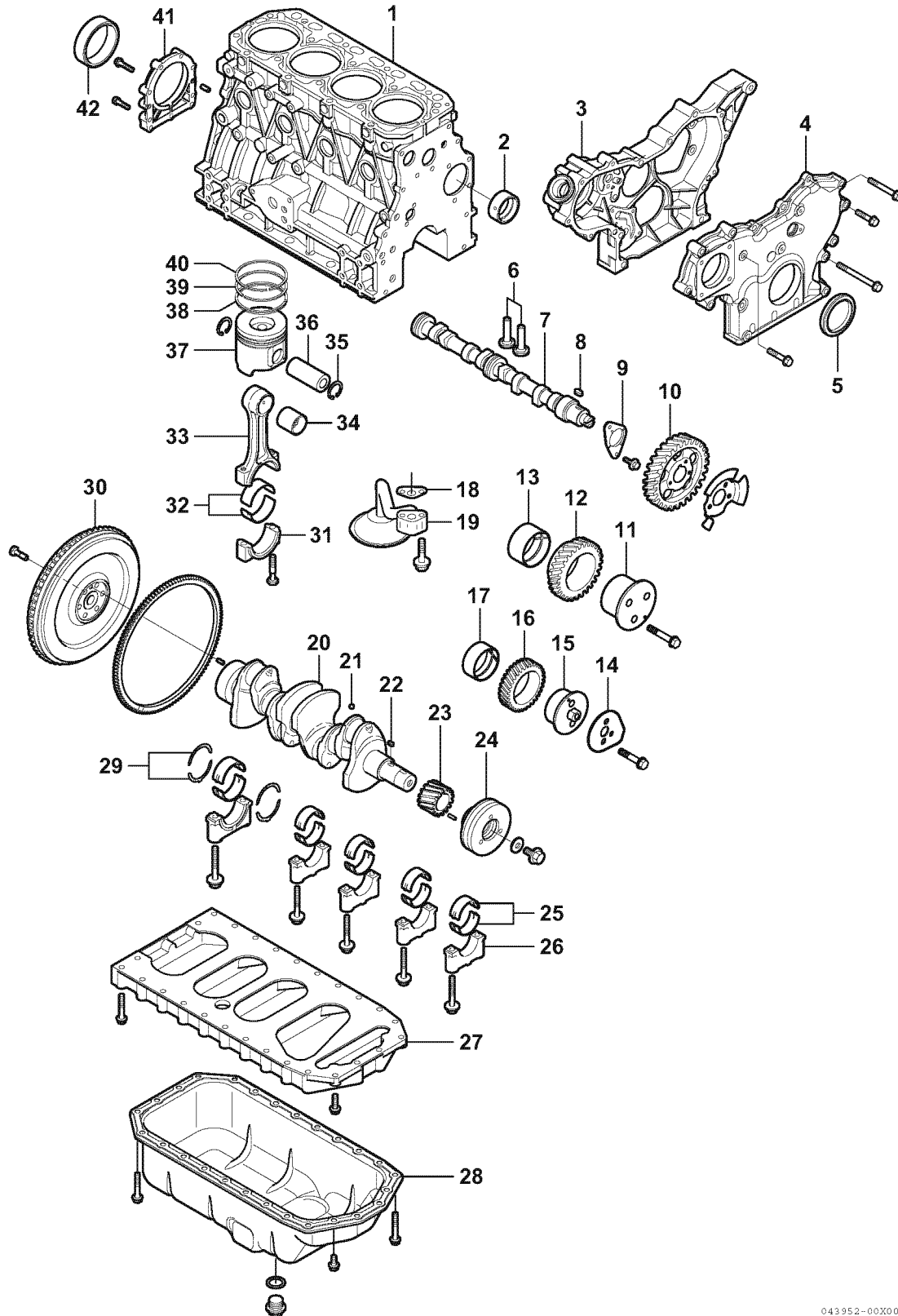

Figure 6-40

7. Apply oil to the contact surface between the adjusting screw and push rod.
8. Rotate the crankshaft. Measure and adjust the valves on the next cylinder. Continue until all the valves have been measured and adjusted.

CRANKSHAFT AND CAMSHAFT COMPONENTS



043952-00X00

Figure 6-41

- 1 – Cylinder block
- 2 – Camshaft bushing
- 3 – Gear case
- 4 – Gear case cover
- 5 – Front crankshaft seal
- 6 – Tappets
- 7 – Camshaft
- 8 – Camshaft gear key
- 9 – Camshaft end plate
- 10 – Camshaft gear
- 11 – Idler gear shaft (A)
- 12 – Idler gear (A)
- 13 – Idler gear bushing (A)
- 14 – Idler gear plate (B)
- 15 – Idler gear shaft (B)
- 16 – Idler gear (B)
- 17 – Idler gear bushing (B)
- 18 – Oil pickup gasket
- 19 – Oil pickup
- 20 – Crankshaft
- 21 – ball
- 22 – Crankshaft gear key
- 23 – Crankshaft gear
- 24 – Crankshaft pulley
- 25 – Main bearing inserts
- 26 – Main bearing cap
- 27 – Oil pan spacer
- 28 – Oil pan
- 29 – Thrust bearings
- 30 – Flywheel
- 31 – Connecting rod cap
- 32 – Connecting rod bearing inserts
- 33 – Connecting rod
- 34 – Wrist pin bushing
- 35 – Circlip
- 36 – Wrist pin
- 37 – Piston
- 38 – Oil ring
- 39 – Second compression ring
- 40 – Top compression ring
- 41 – Crankshaft rear seal housing
- 42 – Crankshaft rear seal

Disassembly of Engine

Prepare a clean, flat working surface on a workbench large enough to accommodate the engine components. Discard all used gaskets, O-rings and seals. Use new gaskets, O-rings and seals on reassembly of engine.

NOTICE

Identify all parts and their location using an appropriate method. It is important that all parts are returned to the same position during the reassembly process.

If the engine will be completely disassembled, the following preliminary steps should be performed:

1. Disconnect the battery cables at the battery. Always disconnect the negative (-) cable first.
2. Remove the throttle cable, electrical connections, intake and exhaust system connections, and fuel supply lines from the engine.
3. Remove the alternator. *See Removal of Alternator on page 12-10.*
4. Drain the engine coolant from the radiator and cylinder block. *See Drain, flush and refill cooling system with new coolant on page 5-19.* Remove the cooling system components from the engine.
5. Remove the engine from the machine. Mount the engine to a suitable engine repair stand having adequate weight capacity.

NOTICE

Be sure to secure the engine solidly to prevent injury or damage to parts due to the engine falling during work on the engine.

6. Clean the engine by washing with solvent, air or steam cleaning. Carefully operate so as to prevent any foreign matter or fluids from entering the engine or any fuel system or electrical components remaining on the engine.

7. Drain the engine oil into a suitable container. Remove the oil filter.
8. Remove the cylinder head. *See Cylinder Head on page 6-25.*
9. Remove fuel supply pump if necessary. *See Removal of Supply Pump on page 7-12 if necessary.*
10. Remove the starter motor. *See Removal of Starter Motor on page 11-8.*

Disassembly of Camshaft and Timing Components

Discard all gaskets, O-rings and seals. Use new gaskets, O-rings and seals on reassembly of the camshaft and timing components.

■ Removal of timing gear case cover

1. Remove the bolt and washer retaining the crankshaft pulley.

NOTICE

Use care not to damage the threads in the end of the crankshaft when removing the crankshaft pulley.

2. Remove the crankshaft pulley using a gear puller.
3. Remove the bolts that retain the gear case cover to the cylinder block and oil pan.
4. Remove the gear case cover (**Figure 6-42, (1)**).

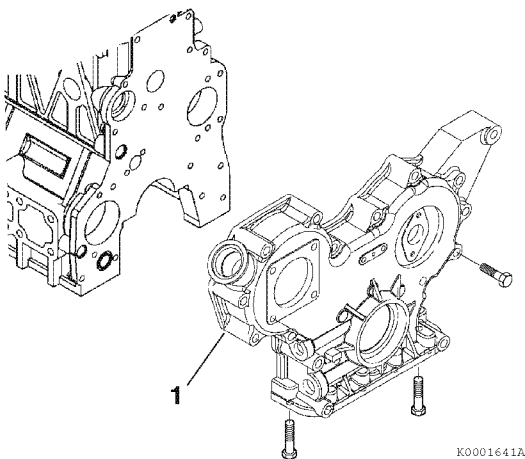

Figure 6-42

■ Checking timing gear backlash

Prior to removing the timing gears, measure the gear backlash and determine the gear wear.

Check the backlash between each pair of mating gears (**Figure 6-43**). If not within specification, replace both mating gears. *See Timing Gear Backlash on page 6-8 for service limits.*

Note: Do not allow the gear being checked to move axially as excess end play could cause a false reading.

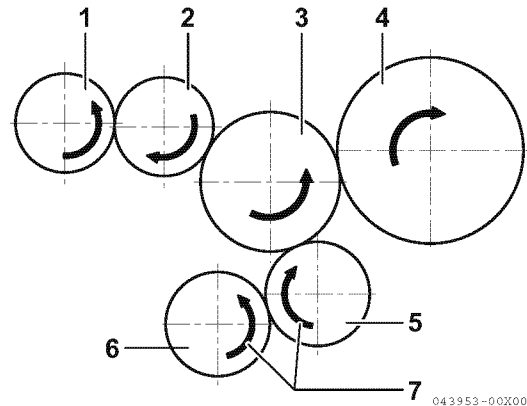

- 1 – Supply pump gear
- 2 – Idler gear (B)
- 3 – Idler gear (A)
- 4 – Camshaft gear
- 5 – Crankshaft gear
- 6 – Lubricating oil pump gear
- 7 – Direction of rotation

Figure 6-43

■ Measuring idler gear-to-crankshaft gear backlash

1. Install a dial indicator as shown in **Figure 6-44**.

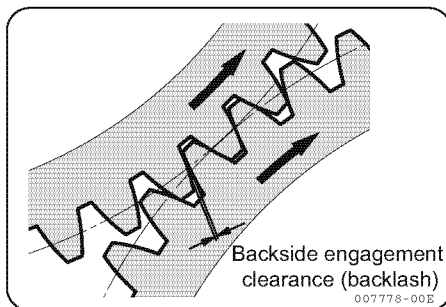
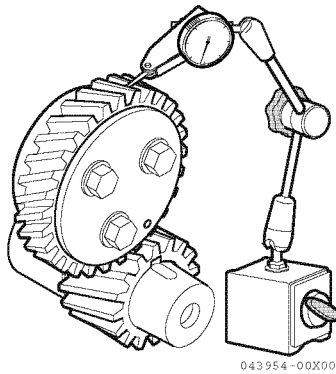

Figure 6-44

2. Rotate the idler gear back and forth to check the idler gear-to-crankshaft gear backlash. The total indicator reading is the backlash. Record the measurement.

■ Measuring idler gear-to-camshaft gear backlash

1. Drive a small wooden wedge between the crankshaft gear and idler gear to prevent the idler gear from rotating.
2. Install the dial indicator to read the camshaft gear backlash. Rotate the camshaft drive gear against the idler gear to measure the backlash. Record the measurement.
3. Check the idler gear-to-fuel injection pump drive gear backlash in the same manner as the camshaft drive gear. Record the measurement.

■ Removal of timing gears

1. Remove the bolts from the idler gear shaft (**Figure 6-45, (1)**). Remove the idler gear shaft, idler gear (**Figure 6-45, (2)**) and bushing (**Figure 6-45, (3)**).

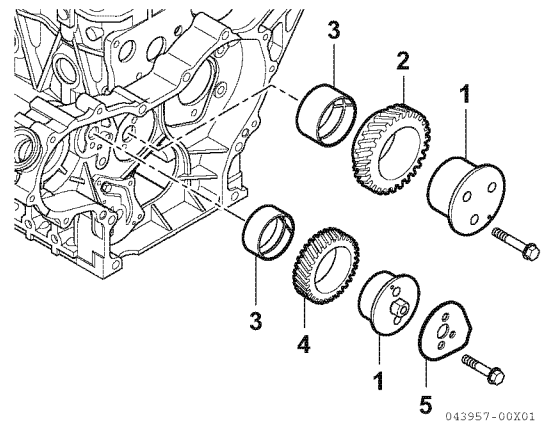

- 1 – Idler gear shaft
- 2 – Idler gear (B)
- 3 – Idler gear bushing
- 4 – Idler gear (A)
- 5 – Plate, idle shaft

Figure 6-45

2. Do not remove the crankshaft gear unless it is damaged and requires replacement. If the gear must be removed, remove it using a gear puller.
3. Removal of the camshaft gear requires the camshaft be removed and placed in a press. Do not remove the camshaft gear unless it or the camshaft is damaged and requires replacement. *See Removal of camshaft on page 6-46.*
4. Remove the pump drive gear using a gear puller.

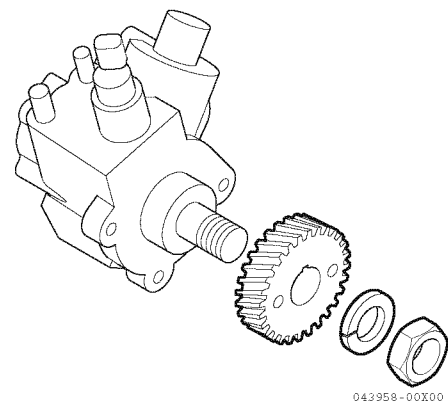

Figure 6-46

■ Removal of oil pan

1. Invert the engine (oil pan up) on the engine stand.
2. Remove the oil pan (**Figure 6-47, (1)**).

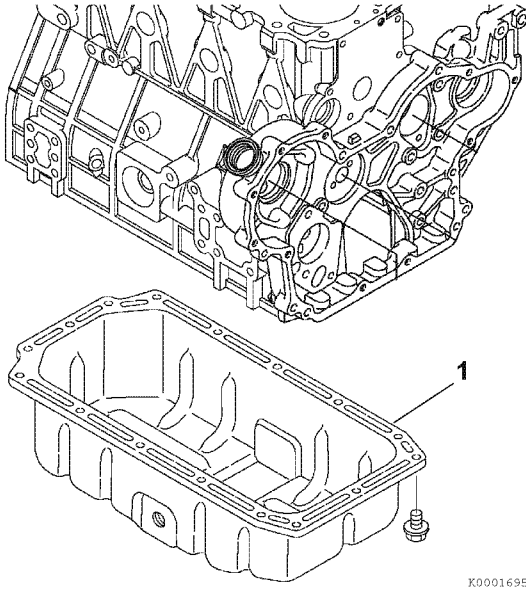

Figure 6-47

3. Remove the oil pickup tube (**Figure 6-48, (1)**) and O-ring (**Figure 6-48, (2)**).

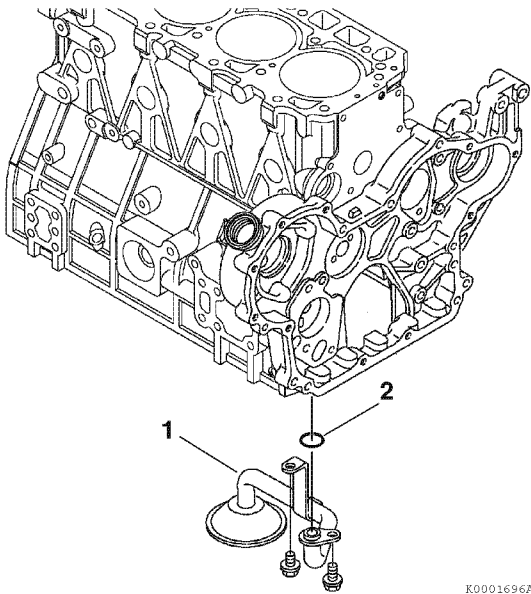

Figure 6-48

■ Removal of camshaft

1. Before removing the camshaft, check the camshaft end play.
 - **Method A:** Install a dial indicator (**Figure 6-49, (1)**) on the cylinder block. Move the camshaft (**Figure 6-49, (2)**) back and forth to measure the end play. Record the measurement. See *Camshaft* on page 6-7 for the service limit.

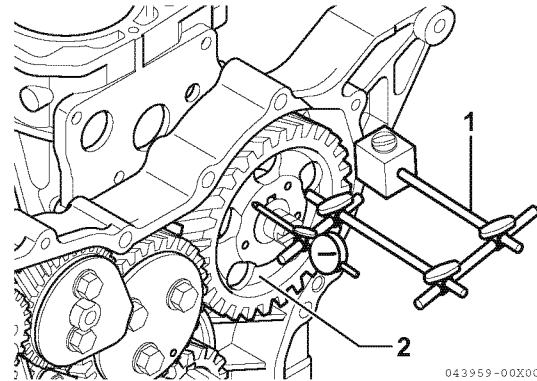

Figure 6-49

- **Method B:** Use a feeler gauge to measure the clearance between the thrust plate (**Figure 6-50, (1)**) and front camshaft bearing (**Figure 6-50, (2)**). See *Thrust Bearing* on page 6-10 for the service limit.

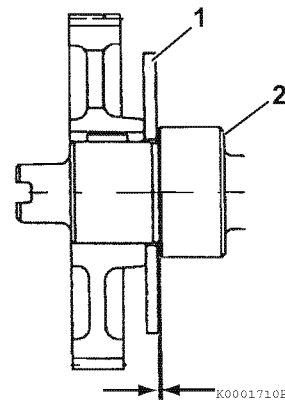

Figure 6-50

- Remove the two bolts (Figure 6-51, (3)) retaining the camshaft thrust plate (Figure 6-51, (1)).

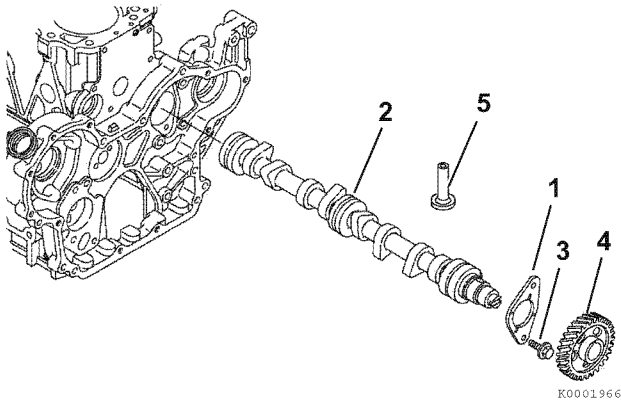

Figure 6-51

- Rotate the engine in the engine stand so that gravity causes the tappets (Figure 6-51, (5)) to drop away from the camshaft lobes.

Note: Rotate the camshaft at least two turns to "bump" any sticking tappets away from the camshaft.

- Slowly pull the camshaft (Figure 6-51, (2)) assembly out of the engine being careful not to damage the front camshaft bushing.

Note:

- If the engine is not installed on an engine repair fixture, stand the engine upright on the flywheel end mounting flange. Rotate the camshaft at least two turns to bump the tappets out of the way to prevent the tappets from interfering with the removal of the camshaft.
- The tappets are "mushroom" shaped and must be removed from inside the engine crankcase.

- Remove the tappets. Mark the tappets so they can be reinstalled in the same location.
- Remove the camshaft drive gear (Figure 6-51, (4)) only if the gear or camshaft require replacement. Use a knife-edge puller and a press to remove the gear. The gear is a shrink-fit and will need to be heated to 356 - 392 °F (180 - 200 °C) to remove.

■ Removal of gear case or front plate

Note: The camshaft must be removed before the gear case can be removed. See Inspection of camshaft on page 6-56.

- Remove the oil pump.

Note: It is not necessary to remove the fuel supply pump from the gear case to remove the gear case. If the fuel supply pump does not need to be repaired, leaving it mounted to the timing gear case will eliminate the need to re-time it during assembly. See Removal of Supply Pump on page 7-12.

- Remove the bolts (Figure 6-52, (4)).
- Remove the gear case (Figure 6-52, (1)) from the cylinder block. Thoroughly clean all old sealant from the mating surfaces.
- Inspect and measure the camshaft bushing. See Camshaft on page 6-7 for the service limit. If damaged or worn beyond service limits, remove the camshaft bushing (Figure 6-52, (3)).
- 4TNV98C, 4TNV98CT:** Remove two O-rings (Figure 6-52, (2)).

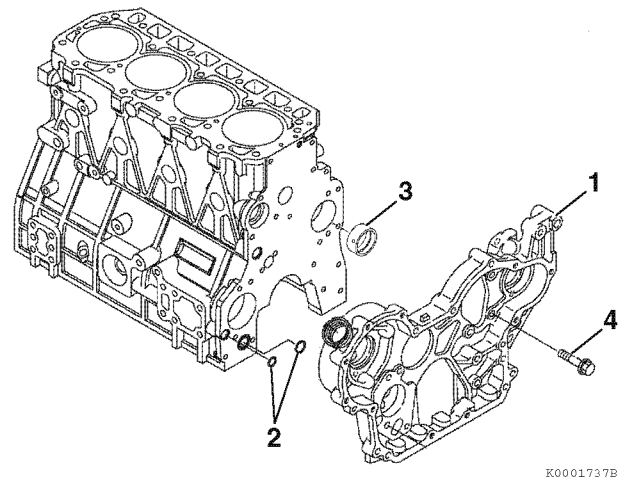

Figure 6-52

6. 3TNV88C - 4TNV86CT: Remove the O-ring (Figure 6-53, (2)) and dowels (Figure 6-53, (5)).

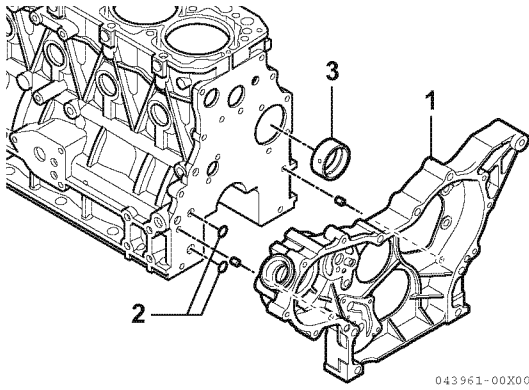

Figure 6-53

Disassembly of Crankshaft and Piston Components

■ Removal of pistons

NOTICE

Keep the piston pin parts, piston assemblies, and connecting rod assemblies together to be returned to the same position during the reassembly process. Label the parts using an appropriate method.

NOTICE

Engines with high operating hours may have a ridge near the top of the cylinders that will catch the piston rings and make it impossible to remove the pistons. Use a suitable ridge reamer to remove ridges and carbon prior to removing the pistons.

Note: Pistons can fall from cylinder block if the engine is inverted. Rotate the engine so the connecting rods are horizontal before removing the connecting rod caps.

1. Using a feeler gauge, measure the connecting rod side clearance as shown (Figure 6-54). See *Connecting Rod* on page 6-14 for the standard limit. If the measurement is out of specification, replace the crankshaft, connecting rod, or both.

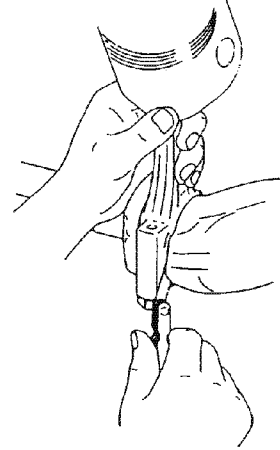

Figure 6-54

2. Measure bearing oil clearance prior to removing the pistons and connecting rods to determine extent of wear. Record the measurements.

NOTICE

Mark the connecting rod caps and connecting rods so the caps and connecting rods stay together.

- 1- Remove the bearing cap. Do not remove the bearing inserts at this time.
- 2- Wipe oil from the bearing insert and crankshaft journal surfaces.
- 3- Place a piece of PLASTIGAGE® (Figure 6-55, (1)) along the full width of the bearing insert.

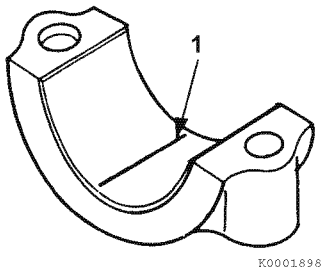

Figure 6-55

NOTICE

Do not rotate the crankshaft when using PLASTIGAGE. A false reading may result.

- 4- Reinstall bearing cap and tighten to specification. See *Special Torque Chart on page 6-16*.
- 5- Remove bearing cap.
- 6- Compare the width of the flattened PLASTIGAGE to the graduation marks on the package (**Figure 6-56, (1)**). The mark that most closely matches the width of the flattened PLASTIGAGE will indicate the bearing oil clearance.

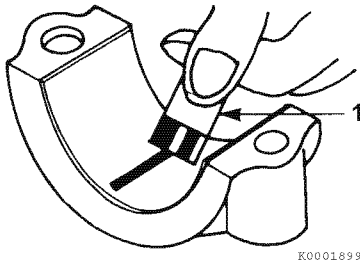

Figure 6-56

- 7- Repeat with remaining connecting rods.

NOTICE

Do not allow the connecting rod to contact the crankshaft journal during piston removal. Damage to the bearing journal may result.

3. Use a wooden dowel against the connecting rod and tap the piston/connecting rod assembly out of the cylinder.
4. Mark the cylinder number on the piston and connecting rod.
5. Remove the bearing inserts (**Figure 6-57, (2)**).
6. Remove the compression rings (**Figure 6-57, (3)**) from the piston using a piston ring expander.
7. Remove the oil ring (**Figure 6-57, (4)**) from the piston using a piston ring expander.

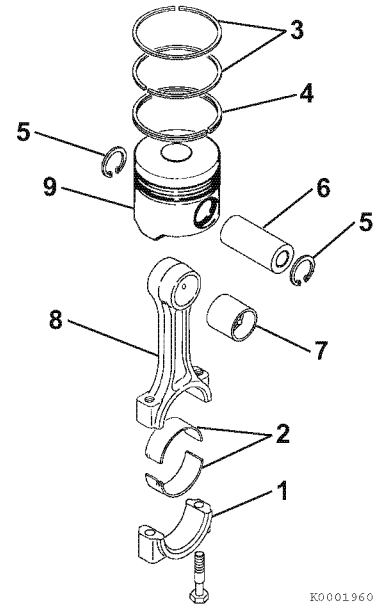

Figure 6-57

8. Remove the circlips (**Figure 6-57, (5)**) from the wrist pin.
9. Remove the wrist pin (**Figure 6-57, (6)**) and connecting rod (**Figure 6-57, (8)**) from the piston (**Figure 6-57, (9)**).
10. Repeat the steps until all pistons are removed and disassembled.

■ Removal of crankshaft

1. Remove the flywheel (**Figure 6-58, (1)**) from the crankshaft.
2. Remove the bolts from the rear oil seal assembly (**Figure 6-58, (2-3)**). Remove the assembly from the engine.

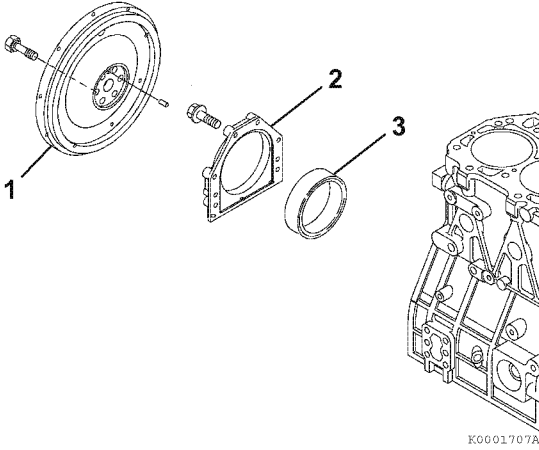

Figure 6-58

3. Before removing the main bearing caps, measure the crankshaft end play. Use either of the following two methods.

- **Method A:** Install a dial gauge (**Figure 6-59, (1)**) on the cylinder block. Move the crankshaft (**Figure 6-59, (2)**) in and out to measure the end play. Record the measurement.

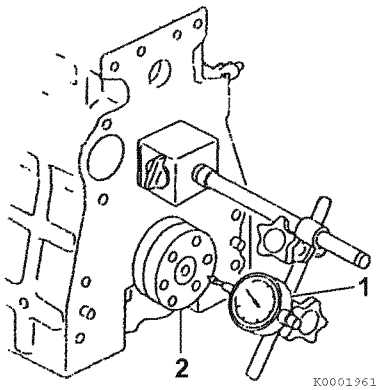

Figure 6-59

- **Method B:** Use a feeler gauge to measure the clearance (**Figure 6-60, (3)**) between the thrust bearing (**Figure 6-60, (1)**) and crankshaft (**Figure 6-60, (2)**). Record the measurement. See *Thrust Bearing* on page 6-10 for the service limit.

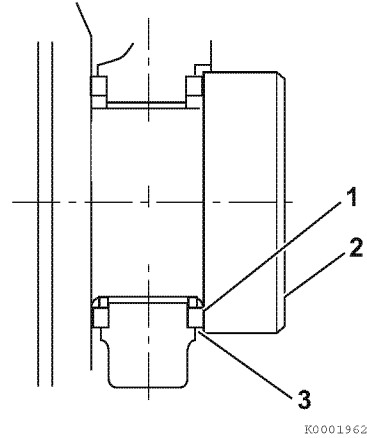

Figure 6-60

4. Remove the main bearing caps (**Figure 6-61, (3)**). Be sure to note the markings on the main bearing caps, or mark them yourself, so they can be reinstalled in the same order as they were removed. Do not remove the bearing inserts at this time.

Note: The "arrows" on the main bearing caps point to the flywheel end of the engine.

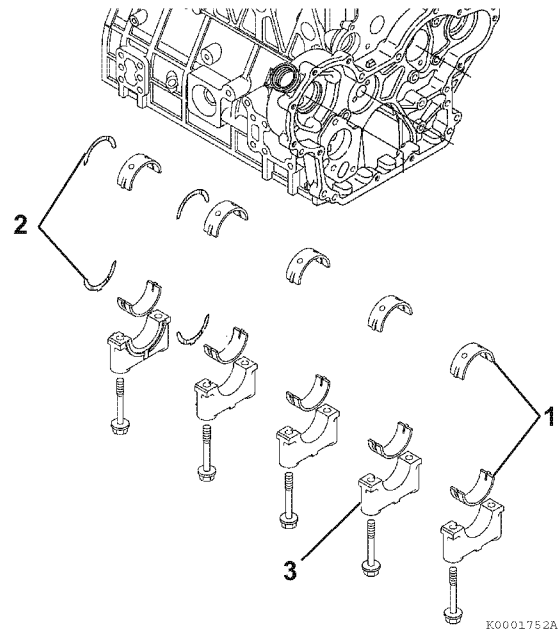

Figure 6-61

5. Measure bearing oil clearance prior to removing the crankshaft to determine extent of wear. Record the measurements.

- 1- Wipe oil from the bearing insert and crankshaft journal surfaces.
- 2- Place a piece of PLASTIGAGE (**Figure 6-62, (1)**) along the full width of each bearing insert.

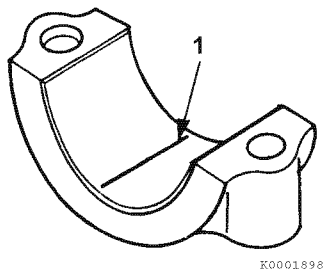

Figure 6-62

NOTICE

Do not rotate the crankshaft when using PLASTIGAGE. A false reading may result.

- 3- Reinstall bearing caps and tighten to specification. *See Special Torque Chart on page 6-16.*
- 4- Remove bearing caps.
- 5- Compare the width of the flattened PLASTIGAGE to the graduation marks on the package (**Figure 6-63, (1)**). The mark that most closely matches the width of the flattened PLASTIGAGE will indicate the bearing oil clearance.

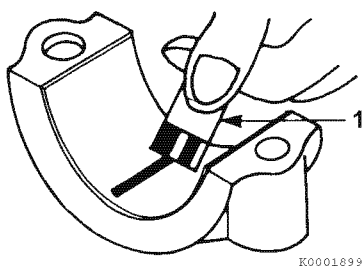

Figure 6-63

6. Remove the crankshaft from the engine.
7. Remove the bearing inserts (**Figure 6-61, (1)**) and thrust bearings (**Figure 6-61, (2)**).

Note: Do not remove the crankshaft gear unless the gear or crankshaft are damaged and require replacement.

8. If necessary, remove the crankshaft gear (**Figure 6-64, (1)**), parallel pin (**Figure 6-64, (2)**) and key (**Figure 6-64, (3)**). If using a gear puller, be careful not to damage the threads in the end of the crankshaft.

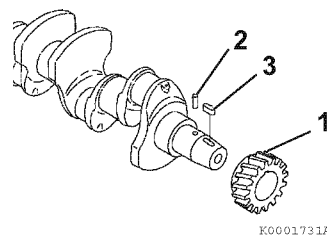
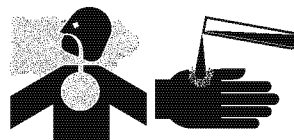

Figure 6-64

Inspection of Crankshaft and Camshaft Components**WARNING****Fume/Burn Hazard!**

- Always read and follow safety related precautions found on containers of hazardous substances like parts cleaners, primers, sealants and sealant removers.

- Failure to comply could result in death or serious injury.

Thoroughly clean all components using a brush and appropriate solvent. Each part must be free of carbon, gasket material, metal filings and other debris.

■ Replacement of crankshaft oil seals

1. Remove the seal (Figure 6-65, (2)) from the cover (Figure 6-65, (1)).
2. Apply a continuous bead of ThreeBond Liquid Gasket No. 1207F, YANMAR Part No. 977770-1207F to the outside diameter of a new oil seal (Figure 6-65, (2)), and install in the gear case cover. Apply lithium grease to the lip of the seal.

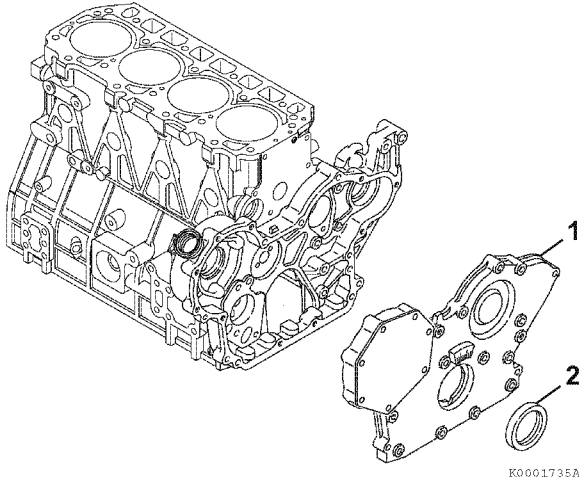

Figure 6-65

3. Remove the rear oil seal (Figure 6-66, (3)) from the seal housing (Figure 6-66, (2)).
4. Apply a continuous bead of ThreeBond Liquid Gasket No. 1207F, YANMAR Part No. 977770-1207F to the outside diameter of a new oil seal (Figure 6-66, (2)), and install in the housing. Apply lithium grease to the lip of the seal.

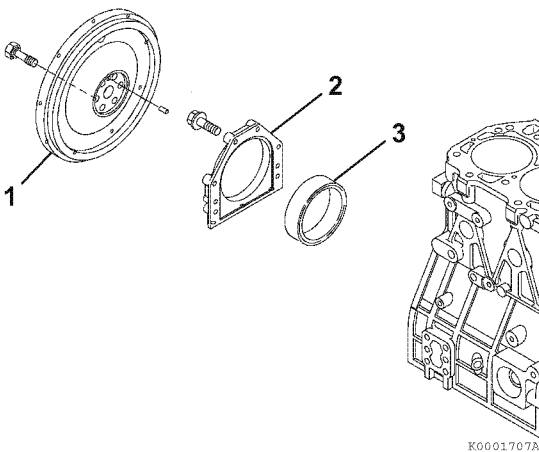

Figure 6-66

■ Measure crankshaft bearing oil clearance

Oil clearance should be checked during disassembly to determine the extent of wear, and during assembly to ensure long engine life. The same procedure is done for both connecting rods and main bearings.

■ Inspection of cylinder block

1. Ensure that oil passages are clear and unobstructed.
2. Check for discoloration or evidence of cracks. If a fracture is suspected, use the color check method or the Magnaflux method to determine if the cylinder block is fractured.
3. Inspect cylinders for roundness, taper, or evidence of scoring. Collect and record the measurements. Consider honing, rebor-ing or replacing the cylinder block if the measurements are not within specification.
 - Take measurements at three places (Figure 6-67) (a, b, c), and in two directions (d and e) in each cylinder.

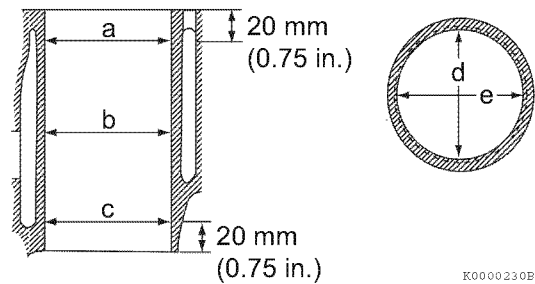

Figure 6-67

■ Inspection of pistons, piston rings and wrist pin

Note:

- On an engine with low hours, the pistons, piston rings may be reused if they are found to be within specifications. The pistons and piston rings must be reinstalled in the same cylinders from which they were originally removed.
- On an engine with high hours, the pistons rings should be replaced and the cylinder honed (See Honing and Boring on page 6-57) or replaced. The piston should be replaced as necessary.

1. Clean piston ring grooves using a piston ring groove cleaning tool. Follow manufacturer's instructions for correct operation.
2. Wash the pistons in an appropriate solvent using a soft brush.
3. Visually inspect each piston for cracks. Pay particular attention to the ring lands between the piston ring grooves.
4. Measure the diameter of the piston skirt at 90° to the wrist pin bore as shown (**Figure 6-68**). Measurements must be taken at a specified distance (**Figure 6-68, (1)**) from the bottom of the piston, based on engine model. Record the measurements. See *Piston* on page 6-10 for specifications.

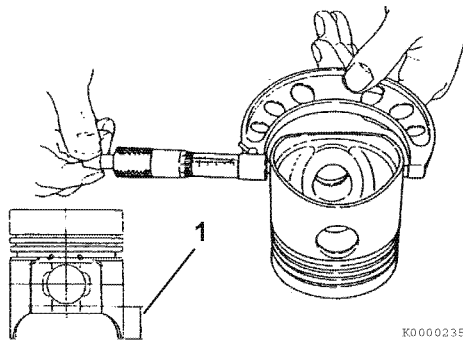

Figure 6-68

5. Subtract the piston measurement from the greatest measurement acquired during cylinder inspection (see *Inspection of cylinder block* on page 6-52) to obtain piston-to-cylinder clearance. Record the measurements. See *Piston* on page 6-10 for specifications.
6. Measure the diameter of the wrist pin bore on both sides of the piston (**Figure 6-69**). See *Piston* on page 6-10 for specifications. Record the measurements.

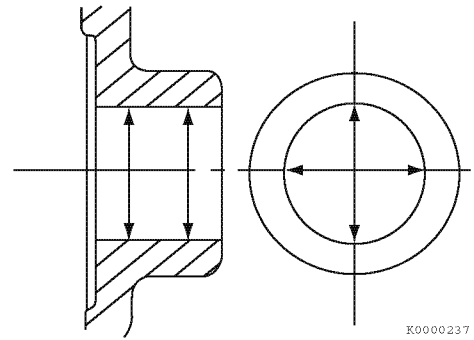

Figure 6-69

7. Measure the outside diameter of the wrist pin in three places and at 90° (**Figure 6-70**). See *Piston* on page 6-10 for specifications. Record the measurements.

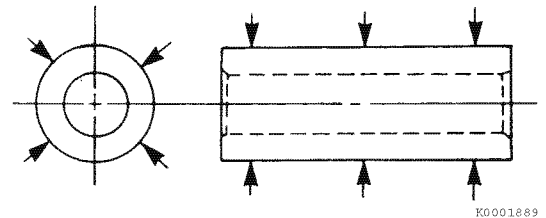
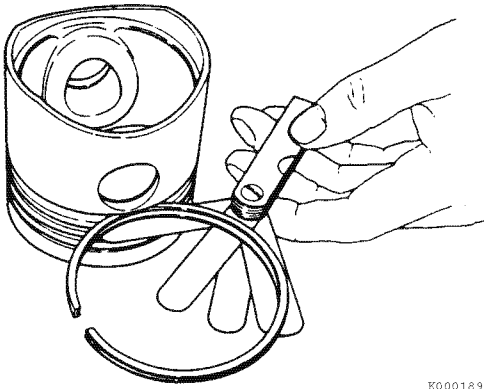

Figure 6-70

8. Using a micrometer, measure the thickness of each piston ring. See *Piston* on page 6-10 for specifications. Record the measurements.

Note:

- On an engine with low hours, the pistons, piston rings and cylinders may be reused if they are found to be within specifications.
 - On an engine with high hours, the pistons rings should be replaced and the cylinder honed (see *Honing and Boring* on page 6-57) or replaced. The piston should be replaced as necessary.
9. Place each compression piston ring in the groove as shown (**Figure 6-71**). Use a feeler gauge to measure the clearance between the piston ring and the piston ring land. Record the measurements. See *Piston Ring* on page 6-11 for specifications. Replace the piston if not within specification.



K0001892

Figure 6-71

10. To measure piston ring end gap, insert each compression piston ring (Figure 6-72, (1)), one at a time, into the cylinder. Use a piston with the piston rings removed to slide the ring into the cylinder bore until it is approximately 1.18 in. (30 mm) (Figure 6-72, (2)) from the bottom of the bore. Remove the piston. Measure the end gap (Figure 6-72, (3)) of each piston ring. Record the measurements. See *Piston Ring* on page 6-11 for specifications.

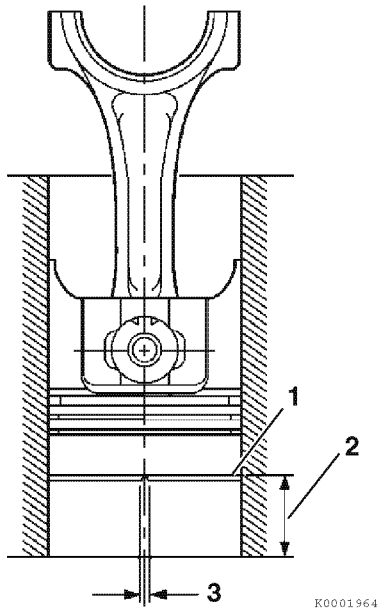

K0001964

Figure 6-72

Note: Always check the piston ring end gap when installing new piston rings. See *Piston Ring* on page 6-11 for specifications. Use a piston ring end gap filing tool to adjust the piston ring end gap on new piston rings.

11. Repeat the above steps for each cylinder and piston assembly.

■ Inspection of connecting rod

1. Measure the wrist pin bushing bore using a bore gauge (Figure 6-73, (1)). Replace the bushing if not within specifications. If the bushing has been removed, measure the inside diameter of the connecting rod small end (Figure 6-73, (2)). See *Connecting Rod* on page 6-14 for specifications.

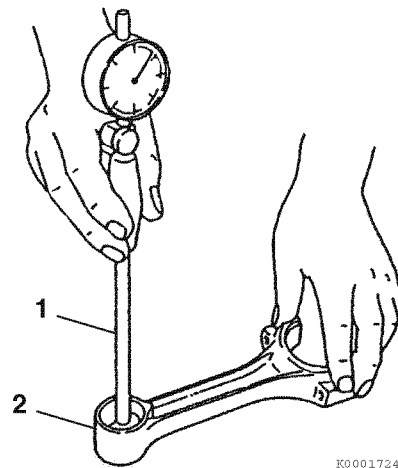

K0001724A

Figure 6-73

2. Place the connecting rod bearing inserts into the connecting rod and connecting rod cap. Install the rod cap and tighten the bolts to the specified torque.

3. Measure the inside diameter. See *Crankshaft* on page 6-9 for specifications.

■ Inspection of tappets

1. Inspect the tappet contact surfaces for abnormal wear (**Figure 6-74, (1)**). Normal wear will be even as shown in (**Figure 6-74, (2)**). Slight surface defects can be corrected using an oilstone.

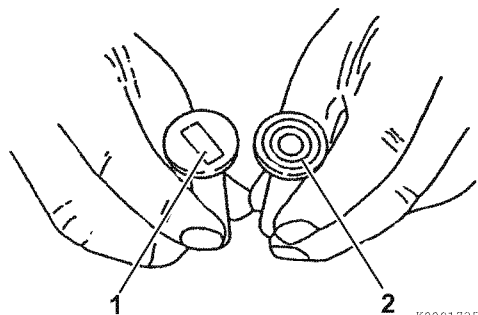

Figure 6-74

2. Measure the outside diameter of the tappet stem (**Figure 6-75, (1)**). See *Tappet* on page 6-14 for the service limit.

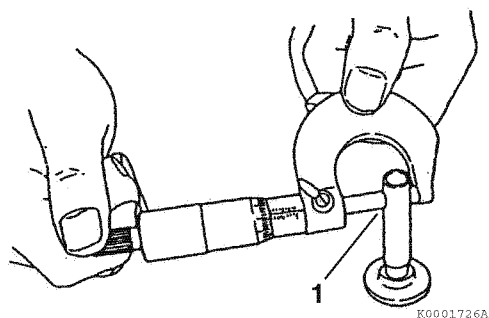

Figure 6-75

3. Measure the tappet bores in the cylinder block. See *Tappet* on page 6-14 for the service limit.

■ Inspection of crankshaft

1. Place the crankshaft end journals (**Figure 6-76, (4)**) on V-blocks.
2. Place a dial indicator (**Figure 6-76, (3)**) on a center main bearing surface.

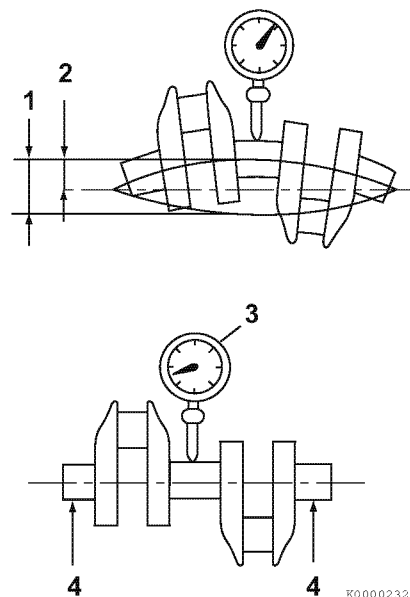

Figure 6-76

3. Rotate the crankshaft and observe runout. See *Crankshaft* on page 6-9 for specifications.
4. Use the color check method or Magnaflux® to inspect the crankshaft for cracks. Replace the crankshaft if evidence of fractures are found.
5. Measure the outside diameter of each crankpin (**Figure 6-77, (2)**) and main bearing journal (**Figure 6-77, (1)**). See *Crankshaft* on page 6-9 for specifications. Take measurements at several places around each bearing surface. If not within specification, grind the journals and install undersize bearings, or replace the crankshaft.

■ Inspection of camshaft

1. Use V-blocks and a dial indicator to check camshaft bend (Figure 6-78). Place the indicator on the center bearing journal.

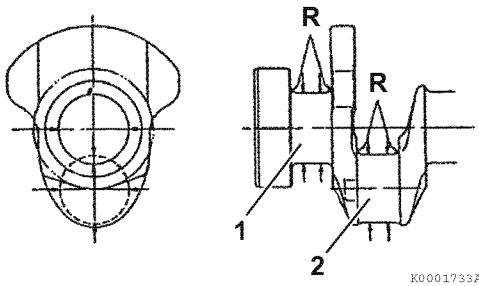
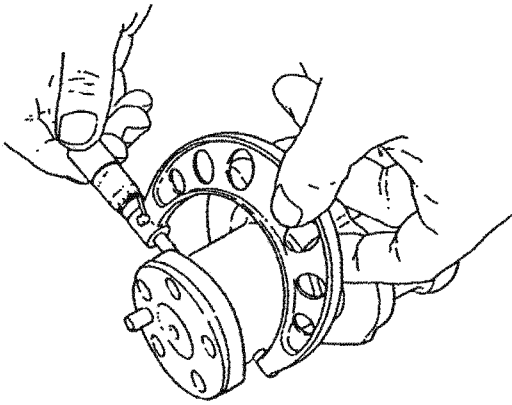
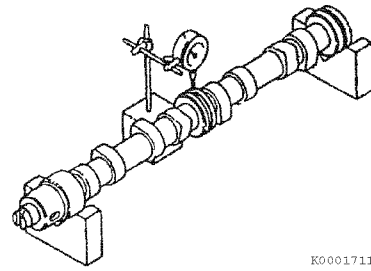

Figure 6-77



K0001711

Figure 6-78

2. Rotate the camshaft and observe the runout. See Camshaft on page 6-7 for specifications.
3. Measure the height of each lobe (Figure 6-79, (1)). See Camshaft on page 6-7 for specifications.

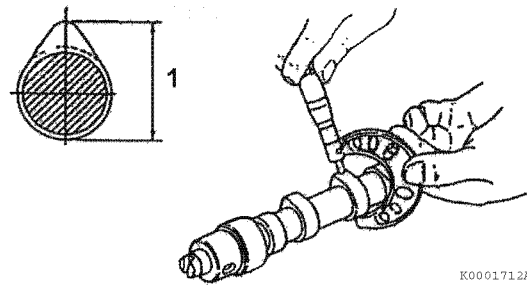

K0001712A

Figure 6-79

4. Measure the diameter of the gear end (Figure 6-80, (1)), intermediate (Figure 6-80, (2)), and flywheel end (Figure 6-80, (3)) bearing journals. See Camshaft on page 6-7 for specifications.

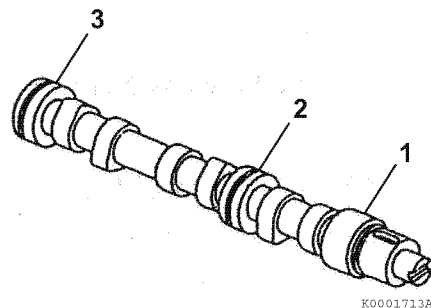

K0001713A

Figure 6-80

■ Inspection of camshaft bushing and bores

1. Measure the I.D. of the front bushing and the remaining bores in the cylinder block. See *Camshaft on page 6-7 for specifications.*
2. If the camshaft bushing is not within specification, replace it using the appropriate service tool. If the remaining bores are not within specification, the cylinder block will require replacement as there are no bearing inserts used.

■ Inspection of idler gear and shaft

1. Measure the outside diameter (**Figure 6-81, (1)**) of the idler gear shaft (**Figure 6-81, (2)**). See *Idler Gear Shaft and Bushing on page 6-8 for specifications.*
2. Measure the inside diameter (**Figure 6-81, (3)**) of the idler gear bushing (**Figure 6-81, (4)**). See *Idler Gear Shaft and Bushing on page 6-8 for specifications.*

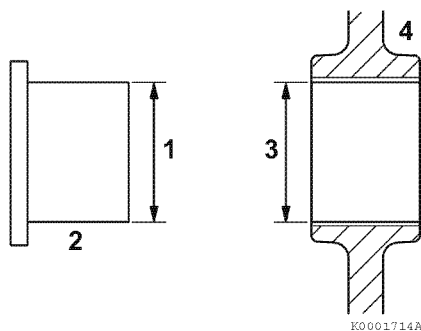

Figure 6-81

Honing and Boring

Pistons must move freely in the cylinders while maintaining adequate compression and oil sealing. If the cylinder walls are scuffed, scored, out-of-round, or tapered beyond specifications, rebore and hone to restore cylinders to usable condition. Slight imperfections can be corrected by honing alone.

1. **Boring** - Significant cylinder damage may be corrected by boring the cylinder to an oversize dimension. Refer to the appropriate parts catalog for available oversize pistons and piston rings.
 - Boring a cylinder should always be done in a properly equipped machine shop.
 - A bored cylinder should always be finished with a hone to properly prepare the cylinder surface so the new piston rings will seat properly.
 - After the cylinder has been bored and honed, install the appropriate oversize pistons and piston rings.
2. **Honing** - Minor cylinder imperfections may be corrected by using a rigid cylinder hone (**Figure 6-83, (1)**). Be sure not to exceed the maximum cylinder bore specification.

Deglazing - A used cylinder that did not require boring or honing, should always be deglazed with a ball hone (**Figure 6-83, (2)**) before installing new piston rings. This will properly prepare the cylinder surface to allow new piston rings to seat properly.

*Note: When honing a cylinder, with either a ridged hone or a ball hone (**Figure 6-82, (1)**), move the rotating hone up and down in the cylinder bore to accomplish a 30° to 40° crosshatch pattern (**Figure 6-82**). This will provide the ideal surface for the proper seating of new piston rings.*

NOTICE

Do not allow the honing tool to operate in one position for any length of time. Damage to the cylinder wall will occur. Keep the tool in constant up-and-down motion.

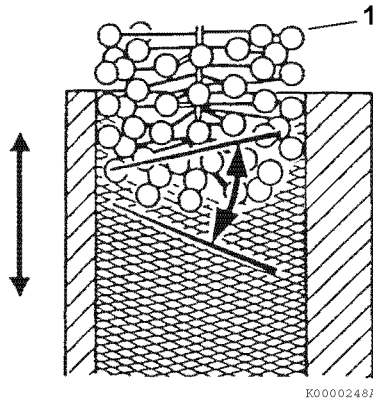

Figure 6-82

- Use a 50:50 mixture of diesel fuel and engine oil as a honing fluid.
- Use a 300-grit hone at 300 - 1200 min⁻¹ (rpm) (Figure 6-83).

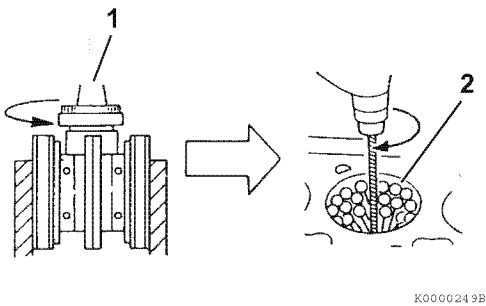

Figure 6-83

NOTICE

Solvents will not adequately remove honing residue, resulting in premature piston and ring wear. Always wash cylinders using hot, soapy water.

- When honing is completed, wash the cylinder block with hot water and soap. The cylinder wall is adequately cleaned when a white rag wiped in cylinder comes out clean. Use brushes to clean all passages and crevices. Rinse with hot water and dry with compressed air. Apply clean engine oil to all steel surfaces to prevent rusting.

Reassembly of Crankshaft and Piston Components

Note:

- Proceed slowly. Make no forced assemblies unless a pressing operation is called for. All parts must be perfectly clean and lightly lubricated when assembled.
- Use new gaskets, seals and O-rings during assembly.
- Liberally apply clean engine oil to all internal parts during assembly.
- All fasteners should be tightened to a given torque. If a special torque is not provided in the Special Torque Chart on page 6-16, tighten to standard torque specifications. See Tightening Torques for Standard Bolts and Nuts on page 4-39.

Reassembly of pistons

1. Select the parts needed to reassemble the piston and connecting rod for one cylinder.
2. If removed, install a new wrist pin bushing (Figure 6-84, (7)) using a press and the appropriate service tool. Be sure to align the oil holes.

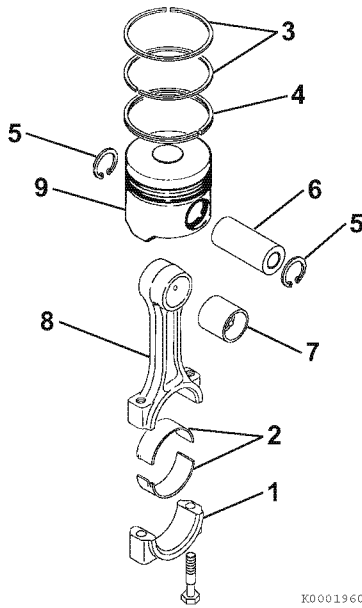

Figure 6-84

- Reinstall one circlip (Figure 6-84, (5)) into the piston. Ensure the circlip is securely seated in the groove.

NOTICE

The piston and connecting rod must be assembled together in the correct orientation. The orientation of the piston and connecting rod are different depending on engine model.

Piston to connecting rod orientation - by model
Orient the piston identification mark stamped on top of the piston on the same side as the rod and cap match marks stamped on the connecting rod.

Note: The actual appearance of the match marks on the piston and connecting rod may vary, but they will always be in the same locations.

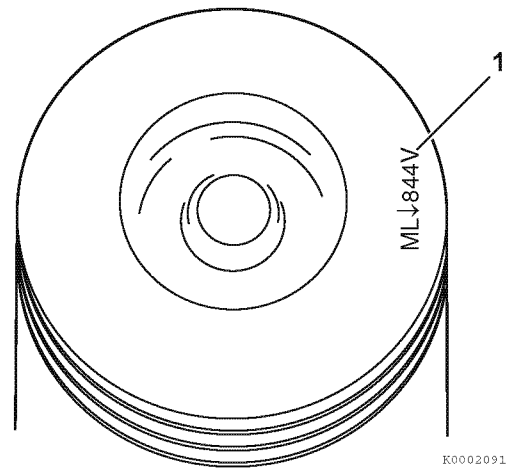

K0002091

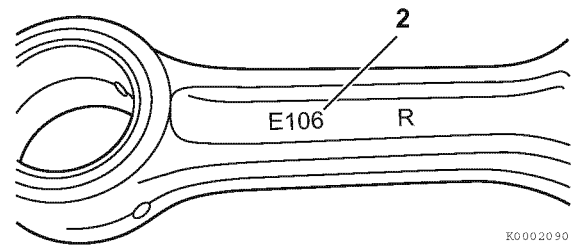

K0002090

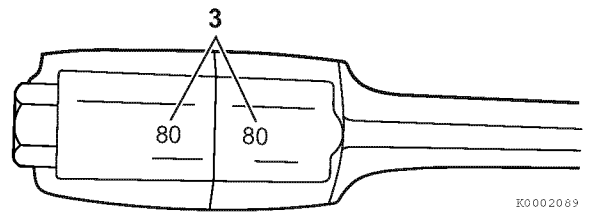

K0002089

- 1 – Piston identification mark
- 2 – Embossed mark on connecting rod
- 3 – Rod and cap match marks

Figure 6-85

Piston assembly - all TNV models

When correctly assembled, the piston identification mark (**Figure 6-86, (2)**) stamped into the top of the piston will be on the same side of the connecting rod as the match marks (**Figure 6-86, (4)**) stamped into the connecting rod and connecting rod cap.

When installed in the cylinder, the piston identification mark (**Figure 6-86, (2)**) stamped on the top of the piston must face the fuel injection pump side (**Figure 6-86, (1)**) of the engine and the embossed mark on the connecting rod (**Figure 6-86, (3)**) must face the flywheel end (**Figure 6-86, (5)**) of the engine.

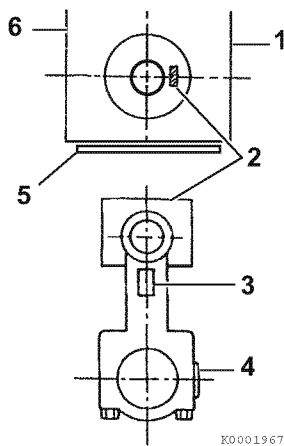

- 1 – Fuel injection pump side of engine
- 2 – Piston identification mark
- 3 – Embossed mark on connecting rod
- 4 – Rod and cap match marks
- 5 – Flywheel end of engine
- 6 – Camshaft side of engine

Figure 6-86

4. Lubricate and reinstall the wrist pin (**Figure 6-88, (6)**) through the piston and connecting rod.
5. Reinstall the second circlip (**Figure 6-88, (5)**) and ensure it is securely seated in the groove.

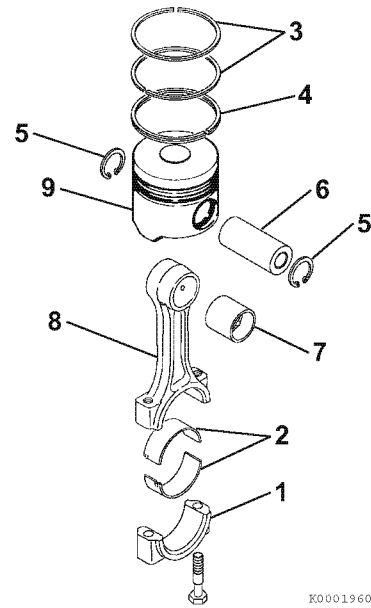

Figure 6-87

Note:

- If installing new piston rings the end gap must be checked and adjusted as necessary. See *Inspection of pistons, piston rings and wrist pin* on page 6-52 for specifications. Use a piston ring end gap filing tool to adjust the piston ring end gap on new piston rings.
- Reinstall the top and second piston rings with the stamped “makers mark” (**Figure 6-89, (1)**) facing the top of the piston. The “makers mark” may vary in appearance but will always be located on the top surface of the piston ring adjacent to the piston ring gap. The oil ring and oil ring expander can be installed either side up.

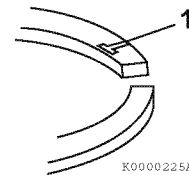

Figure 6-88

NOTICE

Always use a piston ring installation tool (expander) when installing piston rings. Never attempt to install piston rings by hand.

6. Reinstall the oil ring expander (Figure 6-90, (4)). Reinstall the oil ring (Figure 6-90, (3)) with the end gap at 180° from the expander end gap.
7. Reinstall the second compression ring (Figure 6-90, (2)). This ring is identified by its dark color and tapered face profile.
8. Reinstall the top compression ring (Figure 6-90, (1)). This ring is identified by its silver color and barrel-shaped face profile.

NOTICE

The oil ring expander (Figure 6-90, (4)) end gap must be located 180° from the oil ring (Figure 6-90, (3)) end gap.

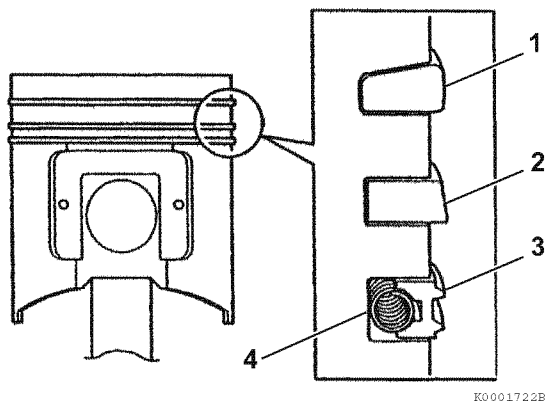
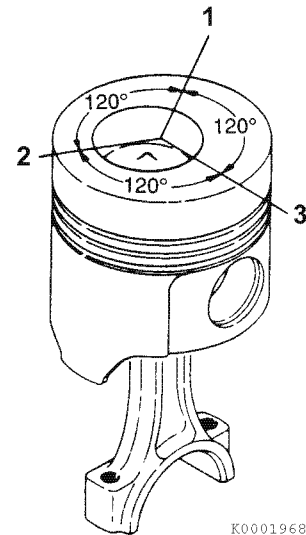

Figure 6-89

9. Stagger the piston ring end gaps at 120° intervals (Figure 6-91, (1, 2, 3)). Do not position the top piston ring end gap in line with the wrist pin.



- 1 – Top compression ring end gap
2 – Second compression ring end gap
3 – Oil ring end gap

Figure 6-90

■ Installation of crankshaft

1. If removed, reinstall the keys and timing gear on the crankshaft.
2. Reinstall new bearing inserts (Figure 6-91, (1)) and thrust bearing (Figure 6-91, (2)) in the cylinder block and main bearing caps. Apply a liberal coat of clean engine oil to the bearings and crankshaft journals.
3. Place the crankshaft into the engine.

NOTICE

The main bearing caps are numbered and have arrows for proper positioning. The No. 1 cap is at the flywheel end. The arrows point toward the flywheel end of the engine.

4. Reinstall the main bearing caps (Figure 6-91, (3)).

- Apply a light coat of clean engine oil to the bearing cap bolts and tighten the bolts to the specified torque in two stages (1/2 then full torque). See *Special Torque Chart* on page 6-16 for specifications.

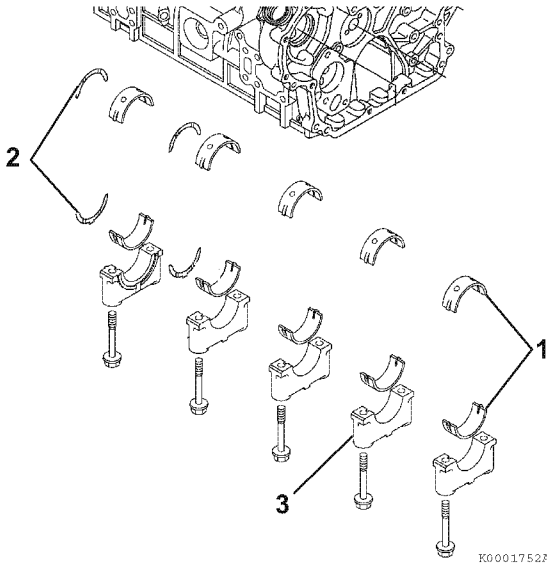

Figure 6-91

- Rotate the crankshaft to assure it turns freely.
- Apply ThreeBond Liquid Gasket No. 1207F, YANMAR Part No. 977770-1207F to the mounting flange of the seal housing (Figure 6-92, (2)).
- Align the seal housing with the two dowel pins.
- Reinstall seal housing and seal assembly.
- Reinstall the flywheel (Figure 6-92, (1)) and tighten the bolts to the specified torque. See *Special Torque Chart* on page 6-16 for specifications.

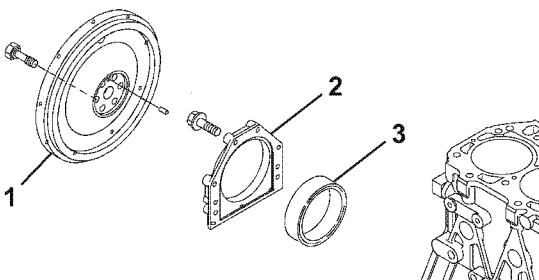

Figure 6-92

Installation of pistons

NOTICE

Do not allow the connecting rod to contact the crankshaft journal during piston installation. Damage to the crankshaft bearing journal may result.

- Lubricate the piston, piston rings, and cylinder with clean engine oil or assembly lubricant.
- Rotate the crankshaft so the crankpin for the piston being installed is near bottom dead center.

NOTICE

Ensure the piston ring gaps are located correctly (Figure 6-93).

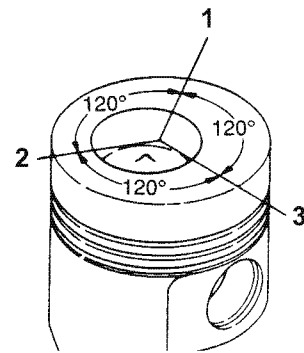

- 1 – Top compression ring end gap
- 2 – Second compression ring end gap
- 3 – Oil ring end gap

Figure 6-93

- Using a piston ring compressor, compress the piston rings.

NOTICE

The piston and connecting rod must be installed in the correct orientation.

Piston orientation to cylinder	
All TNV models	Orient the piston identification mark stamped on top of the piston on the fuel injection pump side of the engine

Piston installation - all TNV models

When correctly assembled, the piston identification mark (**Figure 6-95, (2)**) stamped into the top of the piston will be on the same side of the connecting rod as the match marks (**Figure 6-95, (4)**) stamped into the connecting rod and connecting rod cap.

When installed in the cylinder, the piston identification mark (**Figure 6-95, (2)**) stamped on the top of the piston must face the fuel injection pump side (**Figure 6-95, (1)**) of the engine and the embossed mark on the connecting rod (**Figure 6-95, (3)**) must face the flywheel end (**Figure 6-95, (5)**) of the engine.

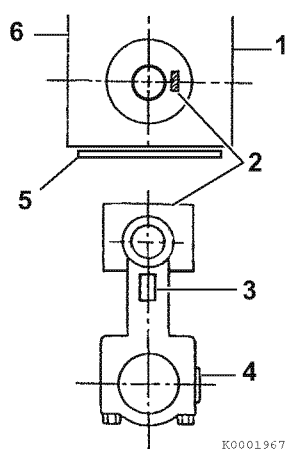

- 1 – Fuel injection pump side of engine
- 2 – Piston identification mark
- 3 – Embossed mark on connecting rod
- 4 – Rod and cap match marks
- 5 – Flywheel end of engine
- 6 – Camshaft side of engine

Figure 6-94

4. Reinstall the bearing inserts (**Figure 6-95, (1)**) in the connecting rod and cap.
5. Apply a liberal coat of clean engine oil to the bearing inserts and crankshaft journal.
6. Apply a light coat of clean engine oil to the rod cap bolts. Reinstall the connecting rod cap (**Figure 6-95, (2)**). Tighten the connecting rod bolts to the specified torque in two stages (1/2 then full torque). See *Special Torque Chart* on page 6-16 for specifications.

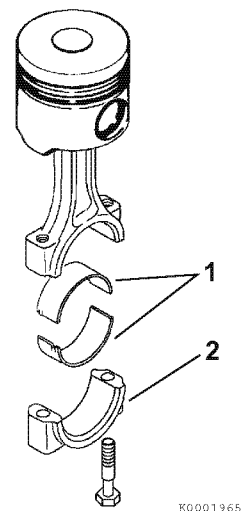

Figure 6-95

7. Reinstall the remaining pistons in their respective cylinders.

Reassembly of Camshaft and Timing Components

■ Installation of gear case

1. If removed, install a new camshaft bushing (Figure 6-96, (3)) using the appropriate service tool.
2. Apply a continuous bead of ThreeBond Liquid Gasket No. 1207F, YANMAR Part No. 977770-1207F to the mounting area of the gear case. Be sure to circle each bolt hole.
3. **4TNV98C, 4TNV98CT:** Install two new O-rings (Figure 6-96, (2)) in the cylinder block.

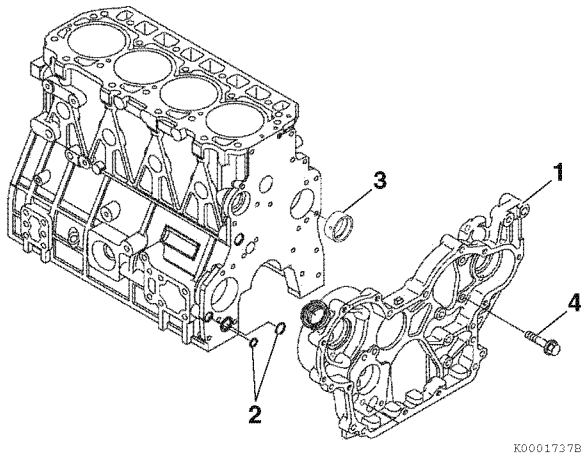

Figure 6-96

4. **3TNV88C - 4TNV86CT:** Reinstall the dowels (Figure 6-97, (5)) and a new O-ring (Figure 6-97, (2)).

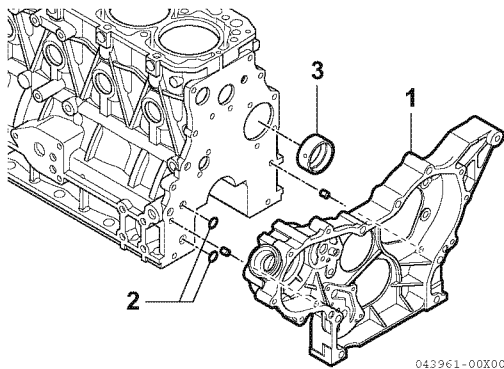

Figure 6-97

5. Reinstall the gear case (Figure 6-96, (1)) or front plate (Figure 6-97, (1)). Tighten the bolts to the specified torque.

■ Installation of camshaft

Note: The gear housing or front plate must be reinstalled prior to installing the camshaft. See Installation of gear case on page 6-64.

1. If removed, reinstall the camshaft end plate (Figure 6-98, (1)), key, and timing gear (Figure 6-98, (4)) onto the camshaft using a press.

Note: Heat the gear to 356 - 392 °F (180 - 200 °C) and press onto the end of the camshaft.

2. Rotate the cylinder block so that gravity will keep the tappets (Figure 6-98, (5)) in place and out of the way of the camshaft lobes when the camshaft is being reinstalled.

Note:

- If the engine is not installed on an engine repair fixture, stand the engine upright on the flywheel end mounting flange.
 - The tappets are “mushroom” shaped and must be installed from inside the engine crankcase.
3. Lubricate the tappets with clean oil or assembly lube. Reinstall the tappets in their respective locations in the cylinder block. Push the tappets fully into the tappet bores so they will not interfere with the installation of the camshaft.
 4. Lubricate the camshaft (Figure 6-98, (2)) with clean engine oil or assembly lube. Slowly insert the camshaft through the front of the engine.
 5. Reinstall and tighten the cap screws (Figure 6-98, (3)).

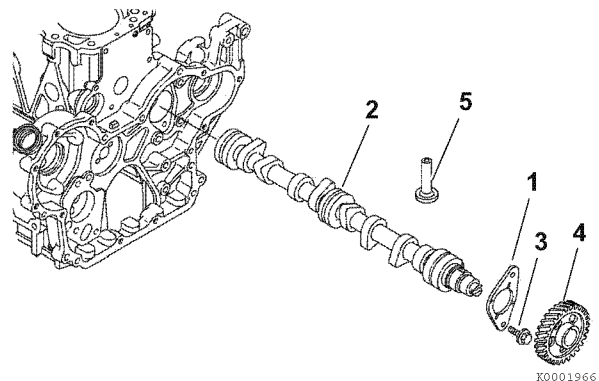
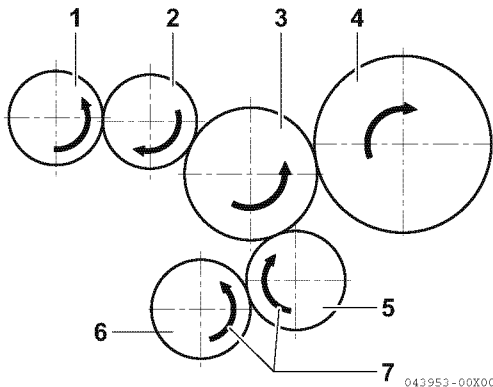

Figure 6-98

■ Installation of timing gears

1. Set the No. 1 piston to top dead center.
2. Rotate the camshaft until the mark (Figure 6-99, (C)) is approximately at the 9 o'clock position.



- 1 – Supply pump gear
- 2 – Idler gear (A)
- 3 – Idler gear (B)
- 4 – Camshaft gear
- 5 – Crankshaft gear
- 6 – Lubricating oil pump gear
- 7 – Direction of rotation

Figure 6-99

3. Lubricate the idler gear (Figure 6-100, (2)), bushing (Figure 6-100, (3)) and idler gear shaft (Figure 6-100, (1)) with clean engine oil.

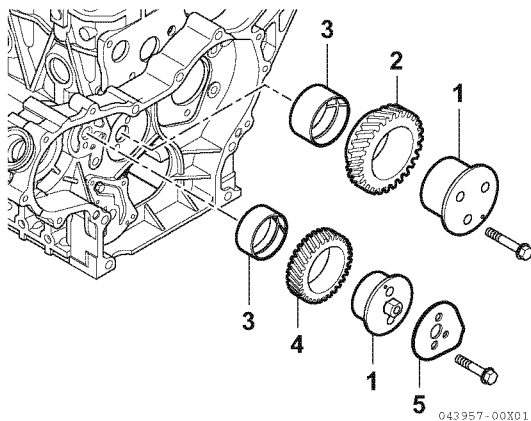

- 1 – Idler gear shaft
- 2 – Idler gear (A)
- 3 – Idler gear bushing
- 4 – Idler gear (B)
- 5 – Plate, idle shaft

Figure 6-100

4. Align the timing gears as shown in (Figure 6-99).
5. Reinstall the idler gear and idler gear shaft. Be sure the oil hole in the bushing is facing toward the top of the engine.
6. Ensure all three timing marks on idle gear A and two timing marks on idle gear B (Figure 6-99, (A, B, C)) are aligned.
7. When all gears are properly aligned, tighten the idler gear retaining bolts to specified torque. See Special Torque Chart on page 6-16 for specifications.

■ Installation of gear case cover

1. Apply a continuous bead of ThreeBond Liquid Gasket No. 1207F, YANMAR Part No. 977770-1207F to the mounting area of the gear case cover (Figure 6-101, (1)). Be sure to circle the bolt holes.
2. Reinstall and tighten the gear case cover bolts.

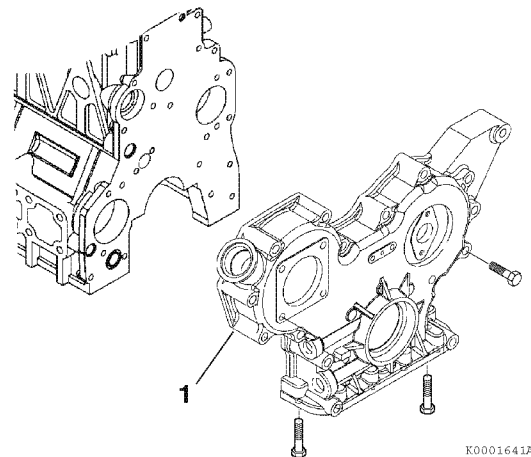

Figure 6-101

3. Reinstall the crankshaft pulley.

NOTICE

Use the crankshaft pulley installation tool (Figure 6-102, (3)) when reinstalling the pulley (Figure 6-102, (1)). The tool will guide the pulley hub and protect the front seal (Figure 6-102, (2)) from damage.

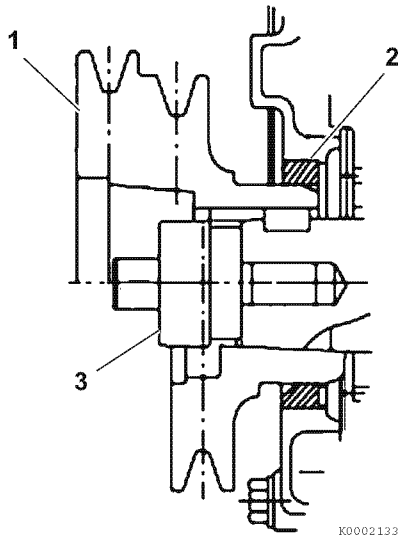

Figure 6-102

4. Reinstall the washer and bolt. Tighten the bolt to the specified torque. See *Special Torque Chart* on page 6-16 for specifications.

■ Installation of oil pan

1. Reinstall the oil pickup tube (Figure 6-103, (1)) using a new O-ring (Figure 6-103, (2)).

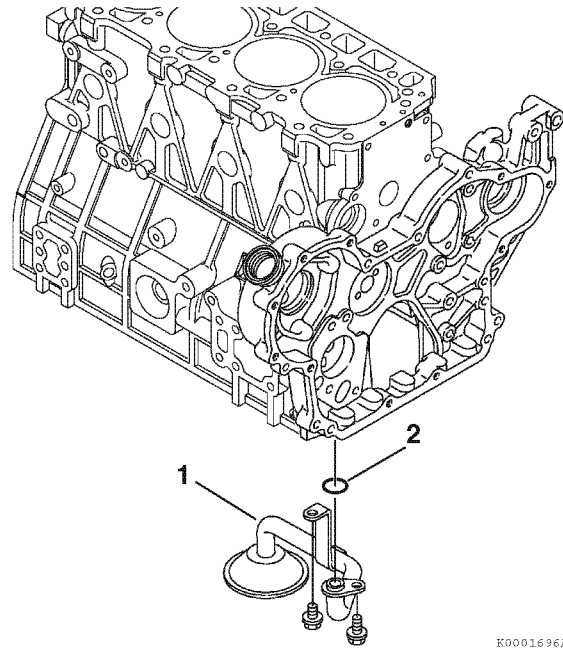

Figure 6-103

2. Apply a continuous bead of ThreeBond Liquid Gasket No. 1207F, YANMAR Part No. 977770-1207F to the mounting surface of the oil pan (Figure 6-104, (1)). Be sure to circle each bolt hole.
3. Reinstall the oil pan and tighten the bolts securely.

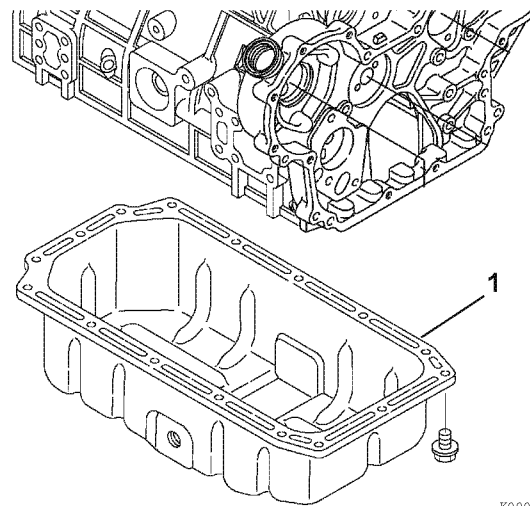
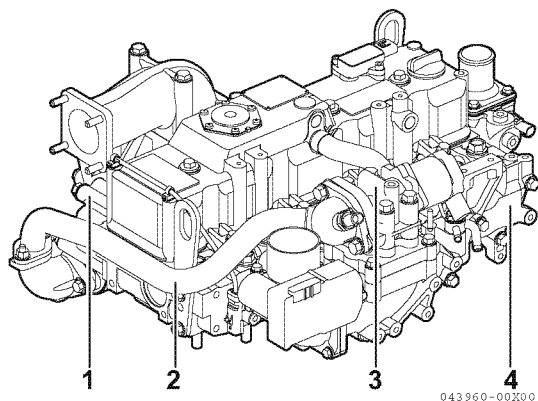

Figure 6-104

Final Reassembly of Engine

1. Reinstall the starter motor.
2. Reinstall the cylinder head. *See Reassembly of cylinder head on page 6-37.*
3. Reinstall the engine in the machine.
4. Reconnect the fuel and coolant lines.
5. Reinstall the alternator.
6. Reconnect all electrical connections.
7. Fill the engine with oil and coolant.
8. Reconnect the battery cables, negative (-) cable last.

EGR SYSTEM**EGR System (Typical Model)**

1 – Exhaust manifold
2 – EGR pipe

3 – EGR valve
4 – Intake manifold

Figure 6-105

Typical Model for Turbocharger Model

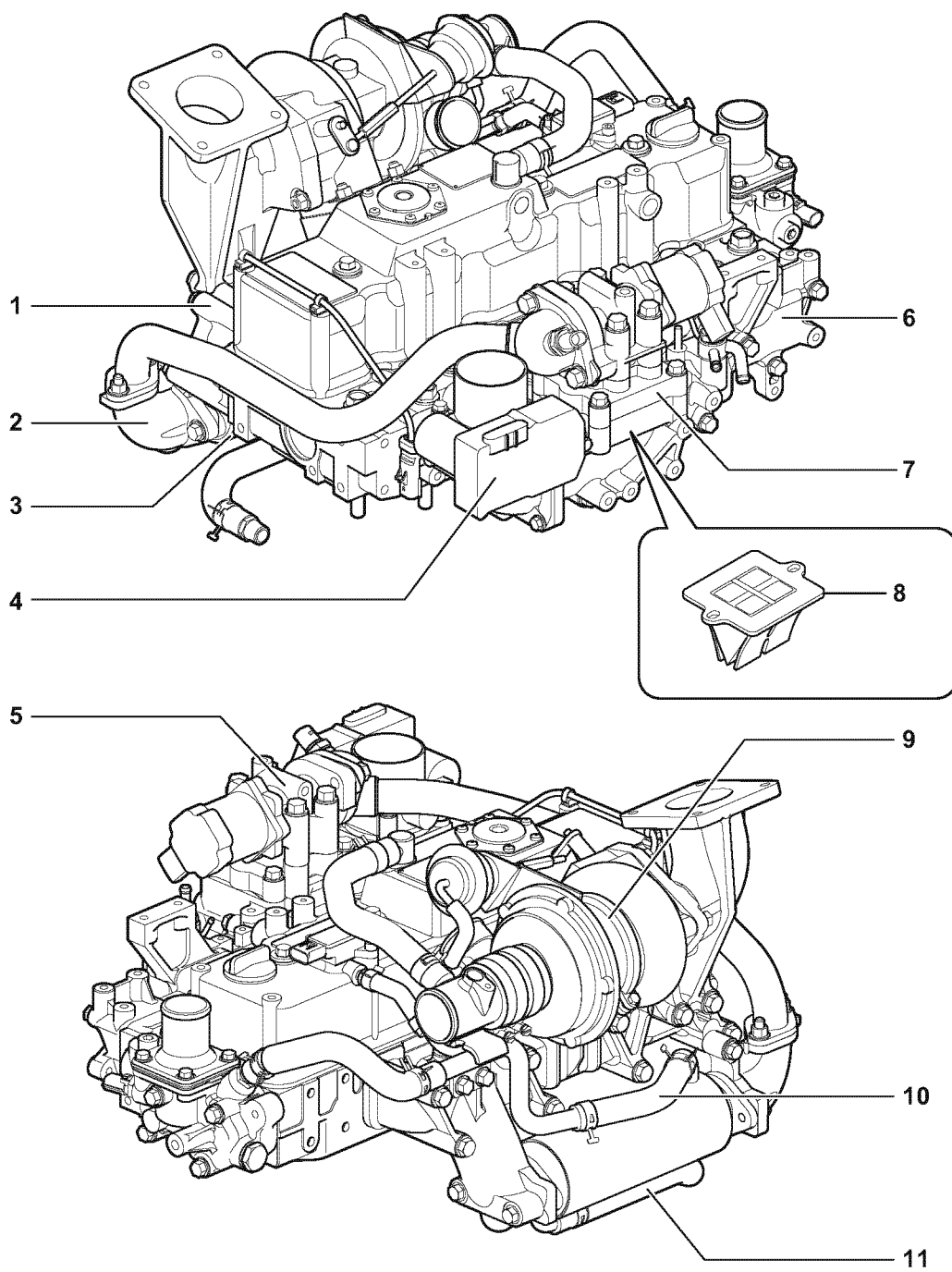

- 1 – Exhaust manifold
- 2 – Elbow, EGR cooler inlet
- 3 – EGR cooler
- 4 – Intake throttle valve
- 5 – EGR valve
- 6 – Intake manifold

- 7 – Spacer, EGR lead valve
- 8 – Lead valve, EGR
- 9 – Turbocharger
- 10 – Cooling water hose, EGR cooler inlet
- 11 – Cooling water hose, EGR cooler outlet

Figure 6-106

EGR System

⚠ DANGER**Scald Hazard!**

- Never remove the radiator cap if the engine is hot. Steam and hot engine coolant will spurt out and seriously burn you. Allow the engine to cool down before you attempt to remove the radiator cap.
- Tighten the radiator cap securely after you check the radiator. Steam can spurt out during engine operation if the cap is loose.
- Always check the level of the engine coolant by observing the reserve tank.
- Failure to comply will result in death or serious injury.

⚠ WARNING**Burn Hazard!**

- Keep your hands and other body parts away from hot engine surfaces such as the muffler, exhaust pipe, turbocharger (if equipped) and engine block during operation and shortly after you shut the engine down. These surfaces are extremely hot while the engine is operating and could seriously burn you.
- Failure to comply could result in death or serious injury.

⚠ WARNING**Entanglement Hazard!**

- Stop the engine before you begin to service it.
- Never leave the key in the key switch when you are servicing the engine. Someone may accidentally start the engine and not realize you are servicing it. This could result in a serious injury.
- If you must service the engine while it is operating, remove all jewelry, tie back long hair, and keep your hands, other body parts and clothing away from moving / rotating parts.
- Failure to comply could result in death or serious injury.

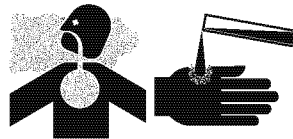
⚠ WARNING**Fume/Burn Hazard!**

- Always read and follow safety related precautions found on containers of hazardous substances like parts cleaners, primers, sealants and sealant removers.
- Failure to comply could result in death or serious injury.

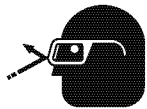
⚠ CAUTION**Flying Object Hazard!**

- Always wear eye protection when servicing the engine and when using compressed air or high-pressure water. Dust, flying debris, compressed air, pressurized water or steam may injure your eyes.
- Failure to comply may result in minor or moderate injury.

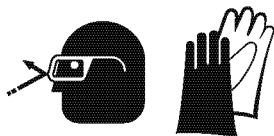
⚠ CAUTION**Coolant Hazard!**

- Wear eye protection and rubber gloves when you handle long life or extended life engine coolant. If contact with the eyes or skin should occur, flush eyes and wash immediately with clean water.
- Failure to comply may result in minor or moderate injury.

NOTICE

When it is necessary to replace an EGR valve, be sure to replace the entire EGR valve assembly. Neither attempt to disassemble and repair the EGR valve, nor replace its individual components.

NOTICE

The EGR system uses steel gaskets at the joints between its components/parts. These steel gaskets are specific to the respective joints. When you remove the system's components/parts and reinstall them, replace the steel gaskets between them with new correct ones.

1. Remove the battery cable from the battery's minus (-) terminal.
2. If there is any additional equipment (such as an air cleaner) installed above the EGR valves, remove it in advance.
3. Remove the EGR valve connectors.

■ **3TNV88C, 4TNV88C, 4TNV98C**

1. Loosen the nuts in the coupling flanges of the exhaust manifold and the EGR pipe.
2. Loosen the bolts in the coupling flanges of the EGR pipe and EGR valve, and remove the EGR pipe.

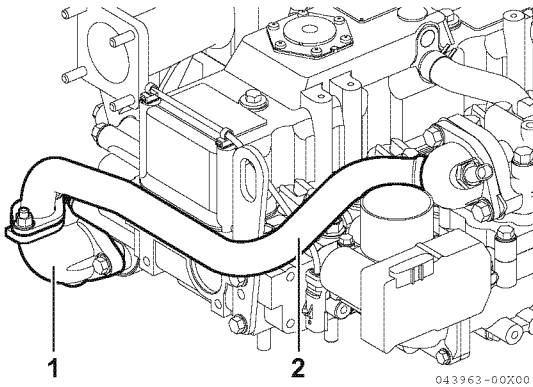

- 1 – Connecting pipe (EGR out)
- 2 – EGR pipe

Figure 6-107

3. Remove the EGR valve.

■ **3TNV86CT, 4TNV86CT, 4TNV98CT**

1. Disconnect the cooling water inlet and outlet hoses from the EGR cooler by loosening the hose clips.
When loosening the clips, put waste cloth or the like beneath the hose joints in case water leaks.
2. Loosen the nuts used to connect the exhaust manifold with the EGR cooler elbow.
3. Loosen the bolts in the coupling flanges of the EGR cooler and EGR pipe, and remove the EGR cooler.
4. Remove the elbow from the EGR cooler.
5. Remove the EGR pipe from the EGR valve.
6. Remove the EGR valve.
7. Remove the spacer (for the lead valve).
8. Remove the lead valve.

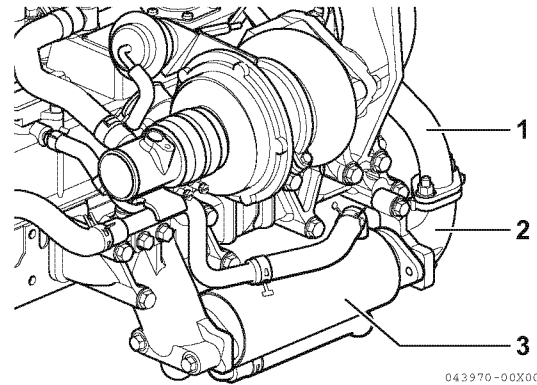

- 1 – EGR pipe
- 2 – Bend (EGR cooler out)
- 3 – EGR cooler

Figure 6-108

■ Cleaning the EGR valves

⚠ WARNING

Fume/Burn Hazard!

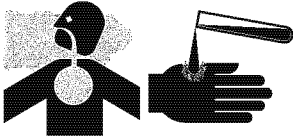

- Always read and follow safety related precautions found on containers of hazardous substances like parts cleaners, primers, sealants and sealant removers.

- Failure to comply could result in death or serious injury.

⚠ CAUTION

Flying Object Hazard!

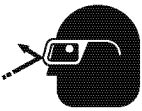

- Always wear eye protection when servicing the engine and when using compressed air or high-pressure water. Dust, flying debris, compressed air, pressurized water or steam may injure your eyes.

- Failure to comply may result in minor or moderate injury.

The EGR valves must be periodically cleaned every 3000 hours because, as exhaust gas circulates through them for a prolonged time, carbon is deposited on their inner surfaces, possibly deteriorating the EGR ratio.

To remove deposited carbon, use compressed air (0.19 MPa (2 kg/cm²) or lower). If the valves are heavily fouled, use carbon cleaner, kerosene, or some other liquid capable of removing carbon as well as a soft brush to clean the valves, taking care not to damage their parts.

When cleaning the valves, take extreme care to prevent water, solvent, cleaner, and other liquid from entering into the motor and coupler terminals; otherwise, failure may result.

NOTICE

Never use high-pressure water or compressed air at greater than 28 PSI (193 kPa; 19686 mmAq) or a wire brush to clean the radiator fins. Radiator fins damage easily.

■ Lead valves

Similarly to the EGR valves, the lead valves must be periodically cleaned every 3000 hours because, as exhaust gas circulates through them for a prolonged time, carbon is deposited on their inner surfaces, possibly deteriorating the EGR ratio.

To remove carbon deposited inside the lead valves, disassemble and clean them.

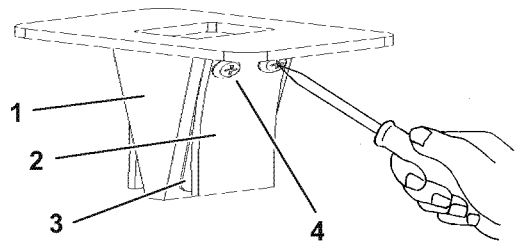

- 1 – Case
- 2 – Stopper
- 3 – Valve
- 4 – Machine screw

Figure 6-109

To remove deposited carbon, use carbon cleaner, kerosene, or some other liquid capable of removing carbon as well as a soft brush or cloth to clean the valves, taking care not to damage their parts.

Upon completion of carbon removal, wipe off water and liquid, make sure that the case, valve, and stopper are free of foreign matter, and then reinstall the valve and related parts.

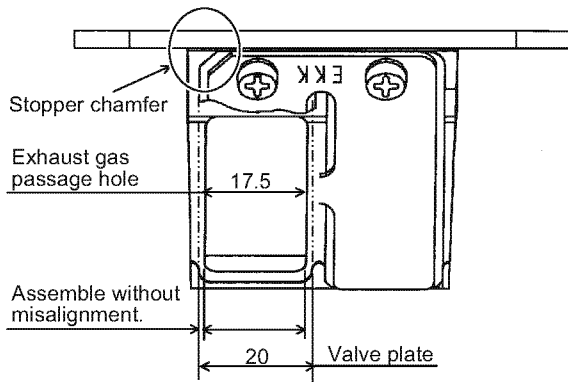

Figure 6-110

■ Precautions for installation

1. The valve and stopper must be installed in their specific orientations. As shown in the figure above, install the valve and stopper so that they are located on the left-hand side of the lead valve.
2. Install the valve by tightening the machine screw while ensuring that it is evenly positioned inside the case window.
3. The machine screw must be tightened with torque of 1.37 ± 0.2 N·m (14 ± 2 kgf·cm).
4. After tightening the machine screw, mark it with a marker to indicate that it has already been tightened.

■ EGR cooler

The EGR cooler must be periodically cleaned every 1500 hours because the exhaust gas passage is subject to carbon deposition and the cooling water transit portion to scale deposition and these depositions gradually deteriorate the cooling of recirculated gas, thus resulting in higher gas temperatures and lower effective circulation amounts (EGR ratio).

To remove deposited carbon from the gas passage, use compressed air (0.19 MPa (2 kg/cm²) or lower). Then dip the gas passage in carbon cleaner, kerosene, or some other liquid capable of removing carbon; leave it dry and blow it with compressed air again.

To clean the water transit portion, dip it in a solution of descaling detergent diluted with water and wash it.

■ EGR pipe and other connecting elbows

The exhaust gas passage is subject to carbon deposition when used over time. To remove deposited carbon from the gas passage, use compressed air (0.19 MPa (2 kg/cm²) or lower). If the exhaust gas passage is heavily fouled, clean it by dipping it in carbon cleaner, kerosene, or some other liquid capable of removing carbon.

NOTICE

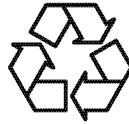

- Always be environmentally responsible.

- Follow the guidelines of the EPA or other governmental agencies for the proper disposal of hazardous materials such as engine oil, diesel fuel and engine coolant. Consult the local authorities or reclamation facility.
- Never dispose of hazardous materials irresponsibly by dumping them into a sewer, on the ground, or into ground water or waterways.
- Failure to follow these procedures may seriously harm the environment.

■ Installing EGR related components/parts

To install these components/parts, reverse the disassembly procedure described above: thus install the lead valve, spacer, EGR valve, EGR pipe, EGR cooler, elbow, cooler cooling water hose, and EGR cooling water hose exactly in this order.

The EGR system uses steel gaskets at the joints between its components/parts. When you remove the system's components/parts and reinstall them, replace the steel gaskets between them with new correct ones.

Intake Throttle

The intake throttle is a device that controls the amount of the engine air intake. The TNV series engines use it for the combustion of soot collected inside the DPF. The intake throttle is driven by the DC motor. The ECU controls the appropriate degree of opening of the throttle depending on the engine speed and load conditions. Accordingly, the engine takes in the minimum required amount of air to increase the exhaust temperature and burn soot inside the DPF.

Precautions for handling the intake throttle

- Do not use a throttle after you have dropped it. Even if it appears okay on the outside, it may have internal damage.
- Do not apply excessive impact or load to the throttle.
- Do not touch the stop screw part, as it has already been adjusted.
- Prevent any foreign matter including oil, dust, and water droplets from entering the air passage part.
- Do not remove the sensor cover installation rivet.
- Consider static electricity and prevent static electric charge of the human body when handling the throttle.
- Do not touch the sensor cover terminal directly.
- Do not touch the throttle valve with your hands when the throttle is energized. Your hands may get pinched in the valve and get injured.
- Do not check operation with the installation surface of the throttle unit pointing down, as the valve protrudes from the installation surface.
- Prevent water and foreign matter from entering the connector connection part.

Characteristics of the intake throttle

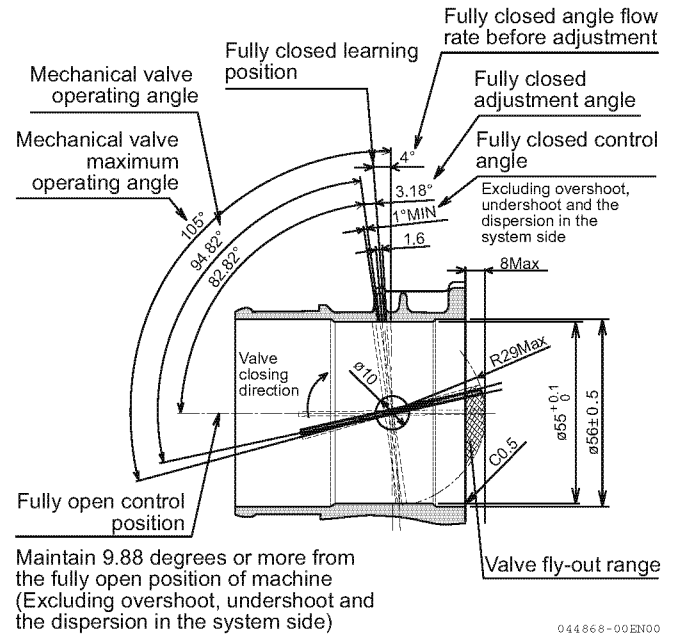

Figure 6-111

Characteristics graph

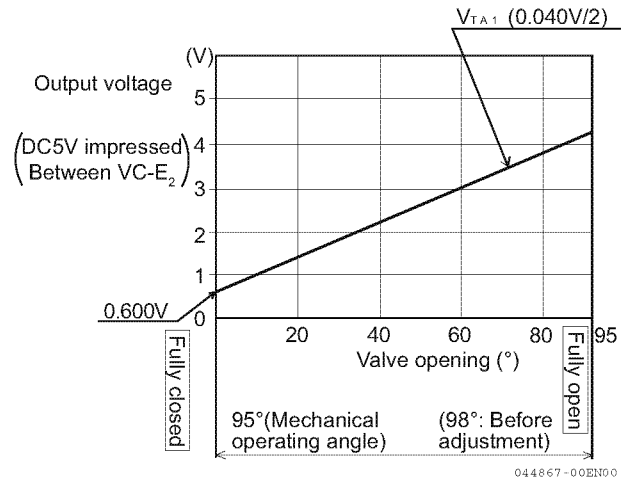

Figure 6-112

This Page Intentionally Left Blank

Section 7

FUEL SYSTEM

	Page
Before You Begin Servicing	7-3
System Structure	7-4
Fuel System Specifications	7-5
Torque Chart for Major Bolts and Nuts	7-5
Fuel System Diagram	7-6
Fuel System Components	7-7
Removal of Common Rail	7-8
Reassembly of Common Rail	7-9
Removal of Injector	7-10
Reassembly of injector	7-10
Removal of Supply Pump	7-12
Reassembly of Supply Pump	7-13

This Page Intentionally Left Blank

BEFORE YOU BEGIN SERVICING

Before performing any service procedures within this section, read the following safety information and review the *Safety section on page 3-1*.

SYSTEM STRUCTURE

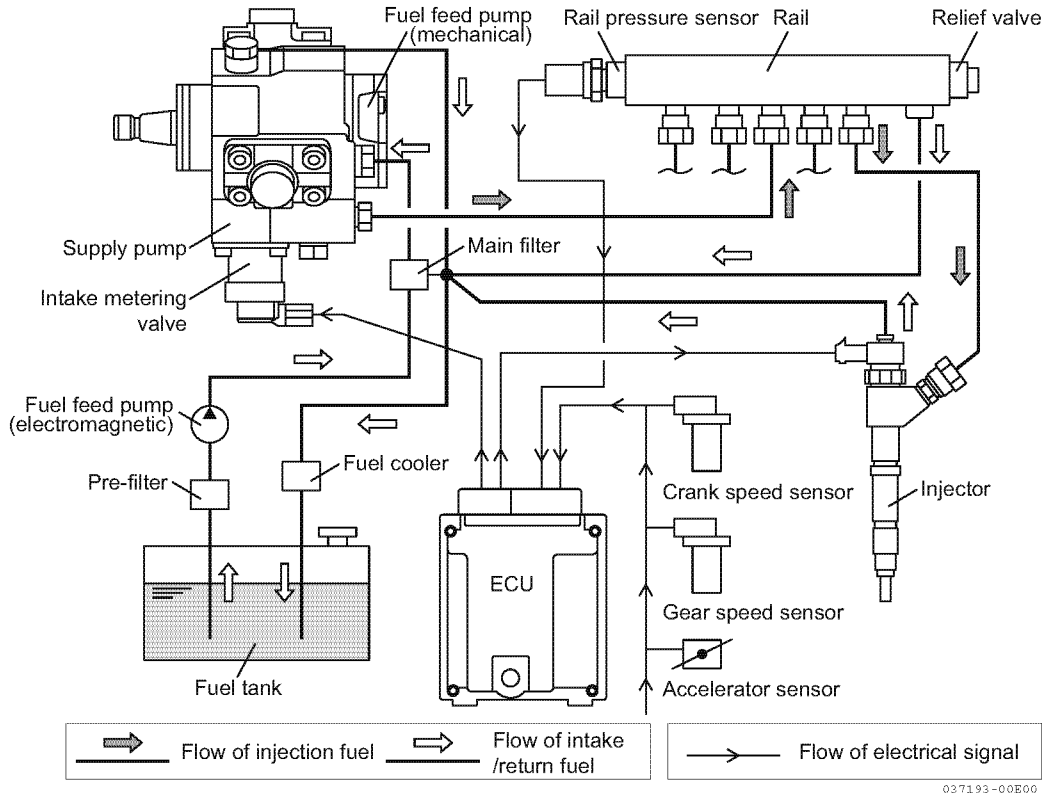

Figure 7-1

■ Supply pump

The fuel passes the pre-filter and is pressure-fed by a fuel feed pump to the main filter, then it arrives at the supply pump. The ECU controls the opening of the intake metering valve and adjusts the fuel intake volume so that the rail pressure is at the target value. The fuel pressurized in the supply pump is fed to the rail.

■ Rail

A pressure of up to 160 MPa is accumulated in the rail. The rail is equipped with a rail pressure sensor and it sends information to the ECU. In the case of an abnormal increase in the rail pressure, the mechanical relief valve opens to prevent the pressure increase.

■ Injector

The ECU controls the injector to maintain optimum injection volume and injection timing and injects the high pressure fuel accumulated in the rail into the cylinder.

■ Crank speed sensor and gear speed sensor

The crank speed sensor is equipped on the flywheel side and the gear speed sensor is equipped on the gear side. Based on these 2 sensor outputs, the ECU recognizes the engine speed and each piston position.

■ ECU

Based on the information from each sensor, ECU determines optimum injection volume, injection timing and rail pressure, and controls the intake metering valve of the supply pump and injector. It also monitors the occurrence of system abnormality at all times. If an abnormality is detected, it notifies the operator and controls the safe running condition of the system.

FUEL SYSTEM SPECIFICATIONS

Torque Chart for Major Bolts and Nuts

Component	Thread diameter and pitch	Tightening torque	Lubricating oil application (Thread portion and seat surface)
Fuel injector bolt	M8 × 1.25 mm	24.4 - 28.4 N·m (2.5 - 2.9 kgf·m)	Not applied
Supply pump gear nut	M18 × 1.5 mm	75 - 85 N·m (7.6 - 8.7 kgf·m)	Not applied
Fuel high pressure pipe nut	M12 × 1.5 mm (Rail)	29.4 - 34.3 N·m (3.0 - 3.5 kgf·m)	Not applied
	M12 × 1.5 mm (Injector)	26.5 - 31.4 N·m (2.7 - 3.2 kgf·m)	Not applied
	M16 × 1.0 mm (Supply pump)	29.4 - 34.3 N·m (3.0 - 3.5 kgf·m)	Not applied
Ball joint bolt	M8	12.7 - 16.7 N·m (1.3 - 1.7 kgf·m)	Not applied
	M10	19.6 - 25.4 N·m (2.0 - 2.6 kgf·m)	Not applied
	M12	24.5 - 34.3 N·m (2.5 - 3.5 kgf·m)	Not applied
	M14	39.2 - 49.0 N·m (4.0 - 5.0 kgf·m)	Not applied
	M16	49.0 - 58.8 N·m (5.0 - 6.0 kgf·m)	Not applied
Hexagon bolt (7T) and nut	M8 × 1.25 mm	10.8 ± 1.0 N·m (1.1 ± 0.98 kgf·m)	<ul style="list-style-type: none"> • Apply 80 % torque when tightened to aluminum alloy. • Apply 60 % torque for 4T and check nut.
	M8 × 1.25 mm	25.5 ± 2.9 N·m (2.6 ± 0.3 kgf·m)	
	M10 × 1.5 mm	49.0 ± 4.9 N·m (5.0 ± 0.5 kgf·m)	
	M12 × 1.75 mm	88.2 ± 9.8 N·m (9.0 ± 1.0 kgf·m)	

FUEL SYSTEM DIAGRAM

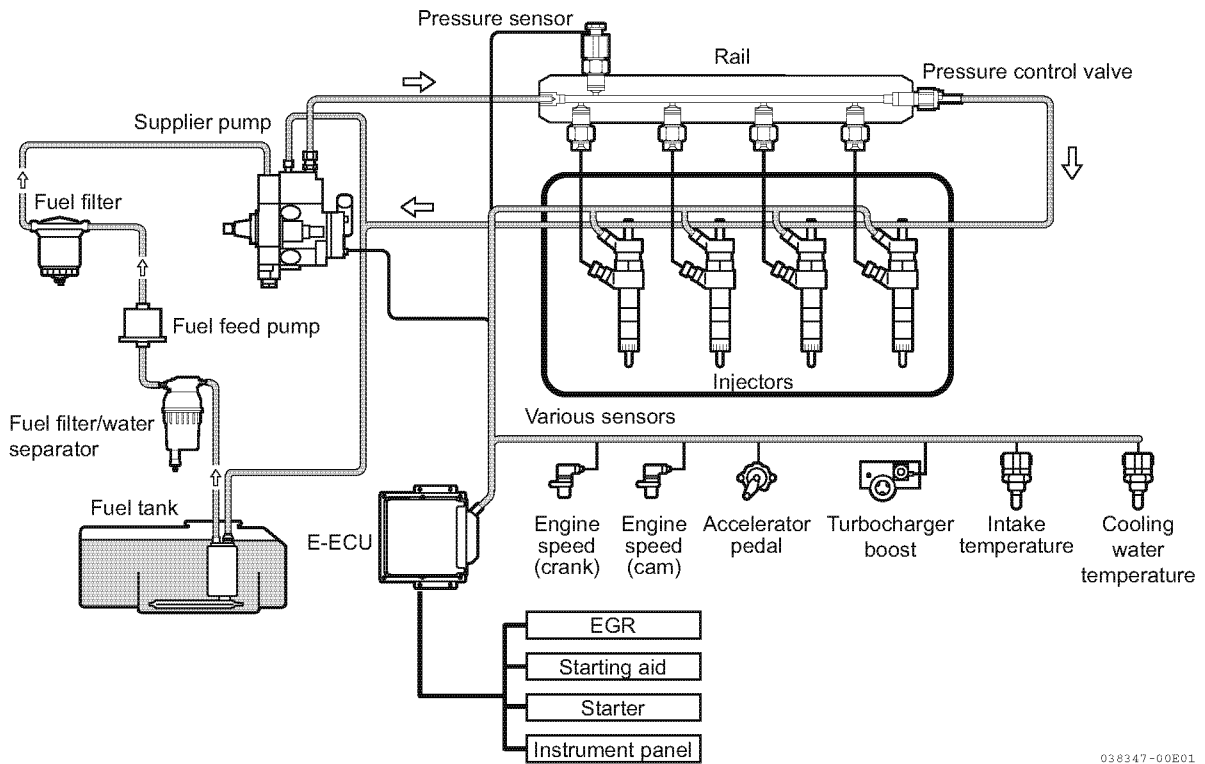

038347-00B01

Figure 7-2

FUEL SYSTEM COMPONENTS

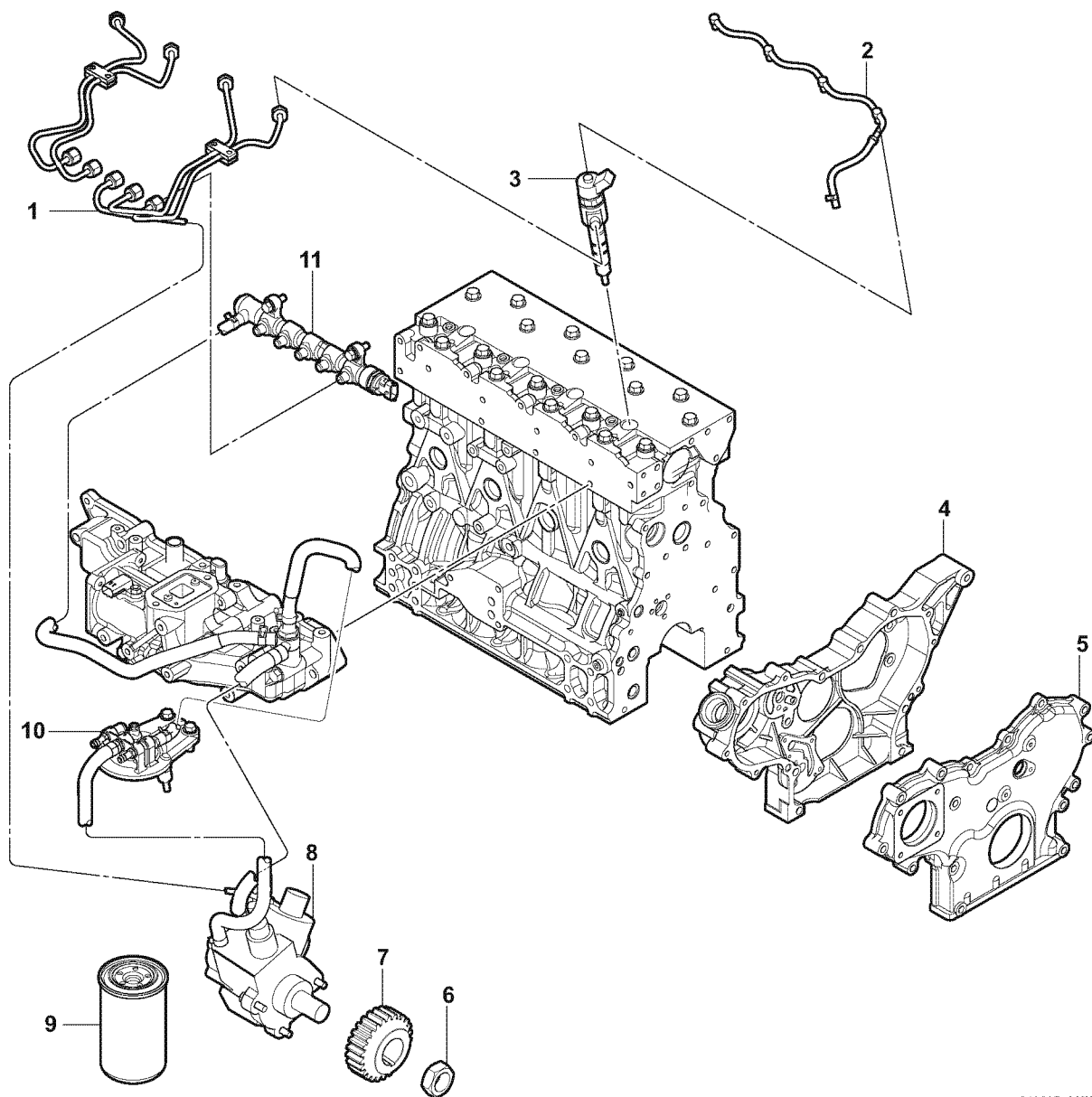

043937-00X00

- | | |
|--|---------------------------------|
| 1 – High-pressure fuel injection lines | 7 – Fuel supply pump drive gear |
| 2 – Fuel return line | 8 – Supply pump |
| 3 – Fuel injector | 9 – Fuel filter |
| 4 – Gear case | 10 – Fuel filter housing |
| 5 – Gear case cover | 11 – Common rail |
| 6 – Fuel supply pump drive gear nut | |

Figure 7-3

Removal of Common Rail

1. Remove the wiring of the injector coupler on the injector.

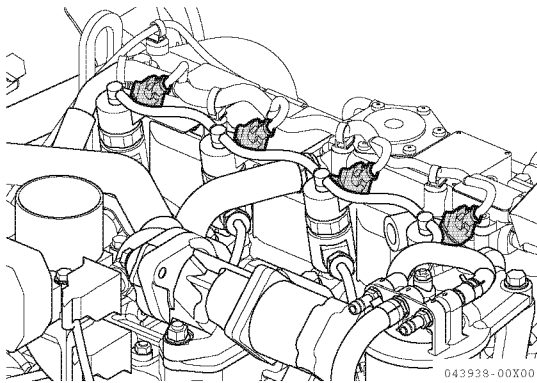

Figure 7-4

2. Remove the wiring coupler of the pressure sensor.

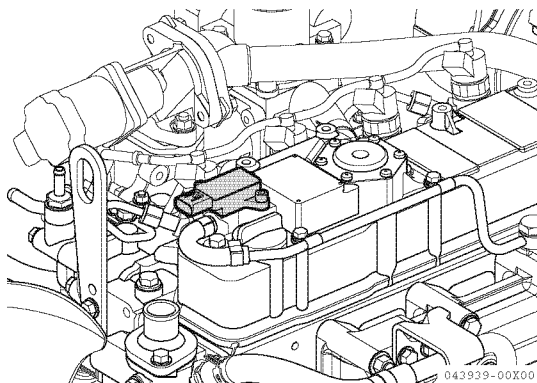

Figure 7-5

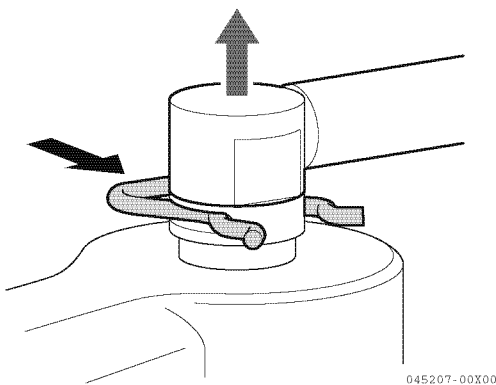

Figure 7-6

3. Remove the leak piping (Figure 7-7, (2)) from the pressure limiter (Figure 7-7, (1)).

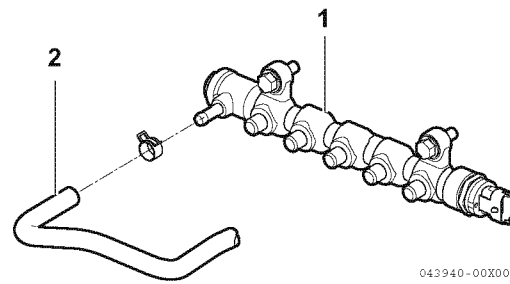

Figure 7-7

4. Removal of engine valve cover
Loosen the nuts and remove the engine valve cover.

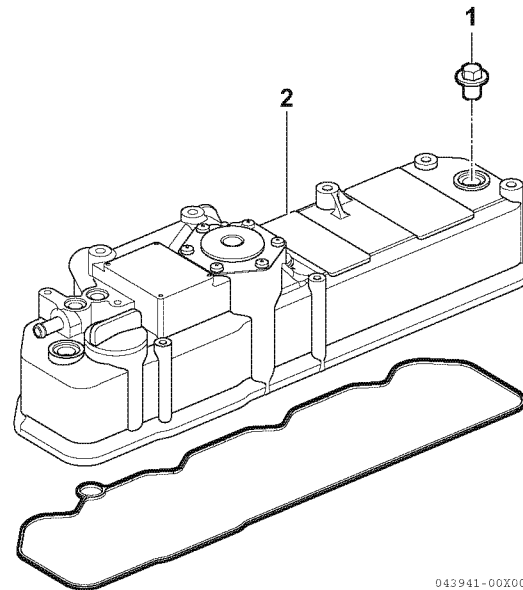

Figure 7-8

5. Removal of high-pressure pipe (1)
(Common rail - injector)
1- Clean around the cap nuts on both the injector and rail sides, using a brush or aspirator.

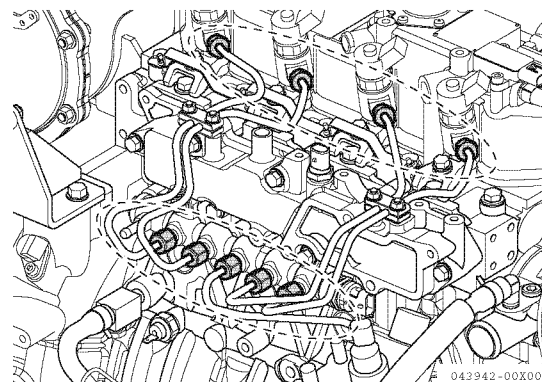

Figure 7-9

- 2- Press the pipe against the bearing surface by hand and loosen the cap nut while holding the pipe using a tool.
 - 3- While pressing and holding the pipe against the bearing surface by hand, loosen and remove the cap nut by hand.
 - 4- Remove the high-pressure pipe.
 - 5- Clean the removed seat portions of the injector with an aspirator or the like and cover them with a vinyl bag.
6. Removal of high-pressure pipe (2)
(Supply pump - common rail)
- 1- Clean around the cap nuts on both the pump and rail sides, using a brush or aspirator.
 - 2- Press the pipe against the bearing surface by hand and loosen the cap nut while holding the pipe using a tool.
 - 3- While pressing and holding the pipe against the bearing surface by hand, loosen and remove the cap nut by hand.
 - 4- Remove the high-pressure pipe.
 - 5- Clean the removed seat portions of the rail inlet with an aspirator or the like and cover them with a vinyl bag.
7. Removal of common rail
Remove the 2 pieces of M8 bolts that attach the common rail, and remove the rail body.

NOTICE

- Loosen the bolts while securely holding the rail body by hand not to drop it.
- Hold the rail body without touching the sensors.

Reassembly of Common Rail

1. Reassembly of common rail body
Temporarily tighten the 2 pieces of M8 bolts by hand while securely holding the common rail body by hand. Then, tighten the bolts to specification.

Tightening torque for M8 bolts	22.6 - 28.4 N·m (2.3 - 2.9 kgf·m)
--------------------------------	--------------------------------------

2. Reassembly of high-pressure pipe (1)
(Common rail - injector)

CAUTION

For high-pressure pipe, use a new one. If you reuse it, the displacement of the working face may occur, causing the fuel leaks.

- 1- Before reinstalling the high-pressure pipe, apply fuel to the cap nut thread portion.
- 2- Temporarily tighten the cap nuts (both the injector and rail sides) while pressing and fixing the seat portions.
- 3- Tighten the cap nuts to specification.

Tightening torque for cap nut (injector side)	26.5 - 31.4 N·m (2.7 - 3.2 kgf·m)
---	--------------------------------------

Tightening torque for cap nut (rail side)	29.4 - 34.3 N·m (3.0 - 3.5 kgf·m)
---	--------------------------------------

3. Reassembly of high-pressure pipe (2)
(Supply pump - common rail)

CAUTION

For high-pressure pipe, use a new one. If you reuse it, the displacement of the working face may occur, causing the fuel leaks.

- 1- Before reinstalling the high-pressure pipe, apply fuel to the cap nut thread portion.
- 2- Temporarily tighten the cap nuts (both the pump and rail sides) while pressing and fixing the seat portions.
- 3- Tighten the cap nuts to specification.

Tightening torque for cap nut (rail side)	29.4 - 34.3 N·m (3.0 - 3.5 kgf·m)
---	--------------------------------------

Tightening torque for cap nut (pump side)	29.4 - 34.3 N·m (3.0 - 3.5 kgf·m)
---	--------------------------------------

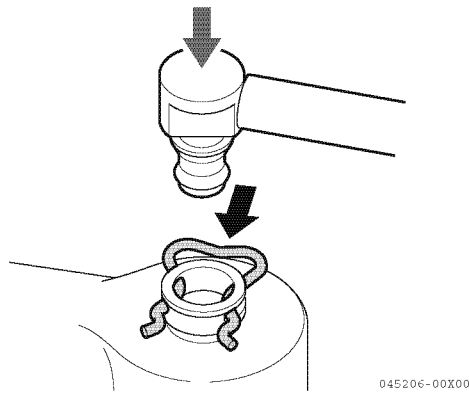

Figure 7-10

4. Be sure the new O-rings are installed on the valve cover nuts.
Reinstall and tighten the valve cover nuts.
5. Reinstall the leak piping from the pressure limiter.

NOTICE

Do not reuse the gaskets.

6. Reinstall the wiring coupler of the pressure sensor.
7. Reinstall the injector wiring coupler.

Removal of Injector

1. Remove the wiring of the injector coupler on the injector and move it to a place where it won't interfere the operation.
2. Remove the fuel return pipe.
At this time, remove the fuel return pipe vertically while pressing the retaining ring (do not remove the retaining ring from the injector).
3. Removal of high-pressure pipe (Common rail - injector)
 - 1- Clean around the cap nuts on both the injector and rail sides, using a brush or aspirator.
 - 2- Press the pipe against the bearing surface by hand and loosen the cap nut while holding the pipe using a tool.
 - 3- While pressing and holding the pipe against the bearing surface by hand, loosen and remove the cap nut by hand.
 - 4- Remove the high-pressure pipe.

- 5- Clean the removed seat portions of the injector with an aspirator or the like and cover them with a vinyl bag.
4. Loosen the injector fixture retainer bolt (M8), and remove the retainer.
5. Remove the injector.

NOTICE

- Do not reuse the injector seats.
- Separate the injectors by each cylinder (mark them).
- Clean the removed injectors and cover them with a vinyl bag.
- Never disassemble the injector. If you change the injector to the new one must be changed with whole injector.

Reassembly of injector

1. Reassembly of injector
Insert the injector into the head by using the new injector seat.

NOTICE

- If you reuse the injector, be sure to reinstall it to the original cylinder.
 - When replacing the injector, replace it in the assembly.
 - If you replace the injector, it is required to write the correction value of each injector to ECU.
 - If rewriting is not correctly done, the engine performance cannot be guaranteed.
 - Be sure to rewrite the correction value by using the SA-D.
 - The correction value is written on the injector.
2. Reassembly of injector fixture retainer
 - 1- Reinstall the injector fixture retainer.
Temporarily tighten the bolt by hand at this time.

3. Reassembly of high-pressure pipe (Common rail - injector)

CAUTION

For high-pressure pipe, use a new one. If you reuse it, the displacement of the working face may occur, causing the fuel leaks.

- 1- Before reinstalling the high-pressure pipe, apply fuel to the cap nut thread portion.
- 2- Temporarily tighten the cap nut (both the injector and rail sides) while pressing and fixing the seat portions.

4. Tighten the injector fixture retainer bolt to specification.

Tightening torque for M8 bolts	24.4 - 28.4 N·m (2.5 - 2.9 kgf·m)
--------------------------------	--------------------------------------

5. Tighten the high-pressure pipe cap nut to specification.

Tightening torque for cap nuts (injector side)	26.5 - 31.4 N·m (2.7 - 3.2 kgf·m)
Tightening torque for cap nuts (rail side)	29.4 - 34.3 N·m (3.0 - 3.5 kgf·m)

6. Reinstall the fuel return pipe.

NOTICE

At this time, insert the fuel return pipe vertically while pressing the retaining ring. Apply light oil to the O-ring so that it does not roll up. (Do not use lubricating oil because alloys such as zinc are used.)

7. Reinstall the wire harness with the M4 nuts.

8. Reinstall the injector wiring coupler.

NOTICE

- If you replace the injector, it is required to write the correction value of each injector to ECU.
- If rewriting is not correctly done, the engine performance cannot be guaranteed.
- Be sure to rewrite the correction value by using the SMARTASSIST.
- The correction value is written on the injector.
- Contact your authorized YANMAR dealer or distributor for replacement of the injector.
- If the correction value of the injector is not correctly written, not only the engine performance cannot be guaranteed, but the engine may also not comply with emission control regulations.

Removal of Supply Pump

1. Remove the wiring coupler of the fuel pressure sensor.
2. Remove the wiring coupler of the SCV.
3. Remove the fuel supply pipe (supply pump inlet) from the fuel filter (supply pump intake).

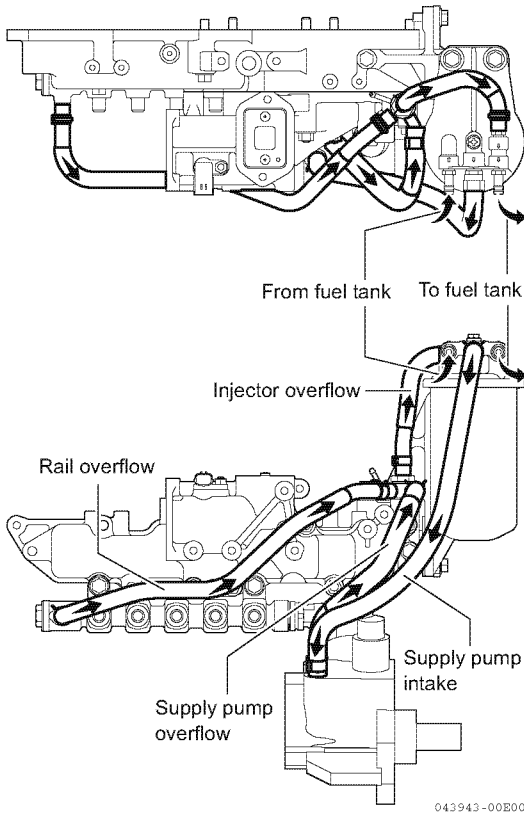

Figure 7-11

NOTICE

The fuel in the pipe may possibly spill at this time. Prepare a fuel container before its removal.

4. Remove the fuel return pipe (supply pump outlet) to the fuel filter (supply pump overflow).
5. Remove the return pipes from the common rail and injector (rail overflow and injector overflow).

NOTICE

Do not reuse either gasket.

6. Remove the fuel filter together with the mounting base from the engine as required.

7. Removal of high-pressure pipe (Supply pump - common rail)
 - 1- Clean around the cap nuts on both the pump and rail sides, using a brush or aspirator.
 - 2- Press the pipe against the bearing surface by hand and loosen the cap nut while holding the pipe using a tool.
 - 3- While pressing and holding the pipe against the bearing surface by hand, loosen and remove the cap nut by hand.
 - 4- Remove the high-pressure pipe.
 - 5- Clean the removed seat portions of the rail inlet with an aspirator or the like and cover them with a vinyl bag.
8. Remove the supply pump cover (drive gear) of the gear case.
9. Remove the supply pump drive gear nut (M18).

NOTICE

Be sure to put an alignment mark between the supply pump drive gear and the idle gear. Do not rotate the crankshaft of the engine after putting the mark.

10. Extract the supply pump drive gear by using the gear extraction tool.

NOTICE

Be sure to use the gear extraction tool.

11. Remove the supply pump nut (M8 - 3 pieces), and remove the supply pump.

NOTICE

Never disassemble the supply pump. If you change the supply pump to the new one must be changed with whole pump.

Reassembly of Supply Pump

1. Reassembly of supply pump body
Align the position of the supply pump drive shaft key (pin) to the drive gear position, and reinstall the supply pump to the gear case.
Reinstall the supply pump with the 3 pieces of M8 nuts.

NOTICE

Be sure to apply oil to the O-ring at the time of installation so that it does not roll up.

Tightening torque for M8 nuts	22.6 - 28.4 N·m (2.3 - 2.9 kgf·m)
-------------------------------	--------------------------------------

2. With the special M18 nuts, reinstall the supply pump drive gear to the supply pump drive shaft.

Tightening torque for M18 nut	75 - 85 N·m (7.7 - 8.7 kgf·m)
-------------------------------	----------------------------------

NOTICE

Make sure that the alignment mark with the idle gear is not misaligned.

NOTICE

Make sure that paint does not get into the coupler while reinstalling the coupler.

3. Reinstall the supply pump cover

Tightening torque for M8 bolts	22.6 - 28.4 N·m (2.3 - 2.9 kgf·m)
--------------------------------	--------------------------------------

4. Reassembly of high-pressure pipe (Supply pump - common rail)

CAUTION

For high-pressure pipe, use a new one. If you reuse it, the displacement of the working face may occur, causing the fuel leaks.

- 1- Before reinstalling the high-pressure pipe, apply fuel to the cap nut thread portion.
- 2- Temporarily tighten the cap nuts (both the pump and rail sides) while pressing and fixing the seat portions.
- 3- Tighten the cap nuts to specification.

Tightening torque for cap nuts (rail side)	29.4 - 34.3 N·m (3.0 - 3.5 kgf·m)
Tightening torque for cap nuts (pump side)	29.4 - 34.3 N·m (3.0 - 3.5 kgf·m)

5. Reinstall the fuel filter (M10 - 2 pieces).

Tightening torque for M10 bolts	35 - 43 N·m (3.6 - 4.4 kgf·m)
---------------------------------	----------------------------------

6. Reinstall the common rail and the return pipe from the injector.
7. Reinstall the return pipe from the supply pump.
8. Reinstall the fuel supply pipe (supply pump inlet) from the fuel filter.
9. Reinstall the wiring coupler of the fuel temperature sensor.
10. Reinstall the wiring coupler of the SCV.

NOTICE

Be sure to perform priming the engine before starting. If air is mixed to the fuel, seizure to the supply pump and the injector may result.

This Page Intentionally Left Blank

Section 8

COOLING SYSTEM

	Page
Before You Begin Servicing	8-3
Introduction.....	8-4
Cooling System Diagram.....	8-4
Engine Coolant Pump Components	8-5
Engine Coolant System Check.....	8-6
Engine Coolant Pump	8-6
Removal of Engine Coolant Pump	8-6
Disassembly of Engine Coolant Pump	8-8
Cleaning and Inspection	8-8
Reassembly of Engine Coolant Pump.....	8-10
Installation of Engine Coolant Pump	8-10

This Page Intentionally Left Blank

BEFORE YOU BEGIN SERVICING

Before performing any service procedures within this section, read the following safety information and review the *Safety* section on page 3-1.

INTRODUCTION

This section of the Service Manual describes the procedures necessary to service the TNV engine coolant pump. This engine coolant pump is representative of the coolant pumps used on other TNV model engines. For specific part detail, see the parts catalog for the engine you are working on.

COOLING SYSTEM DIAGRAM

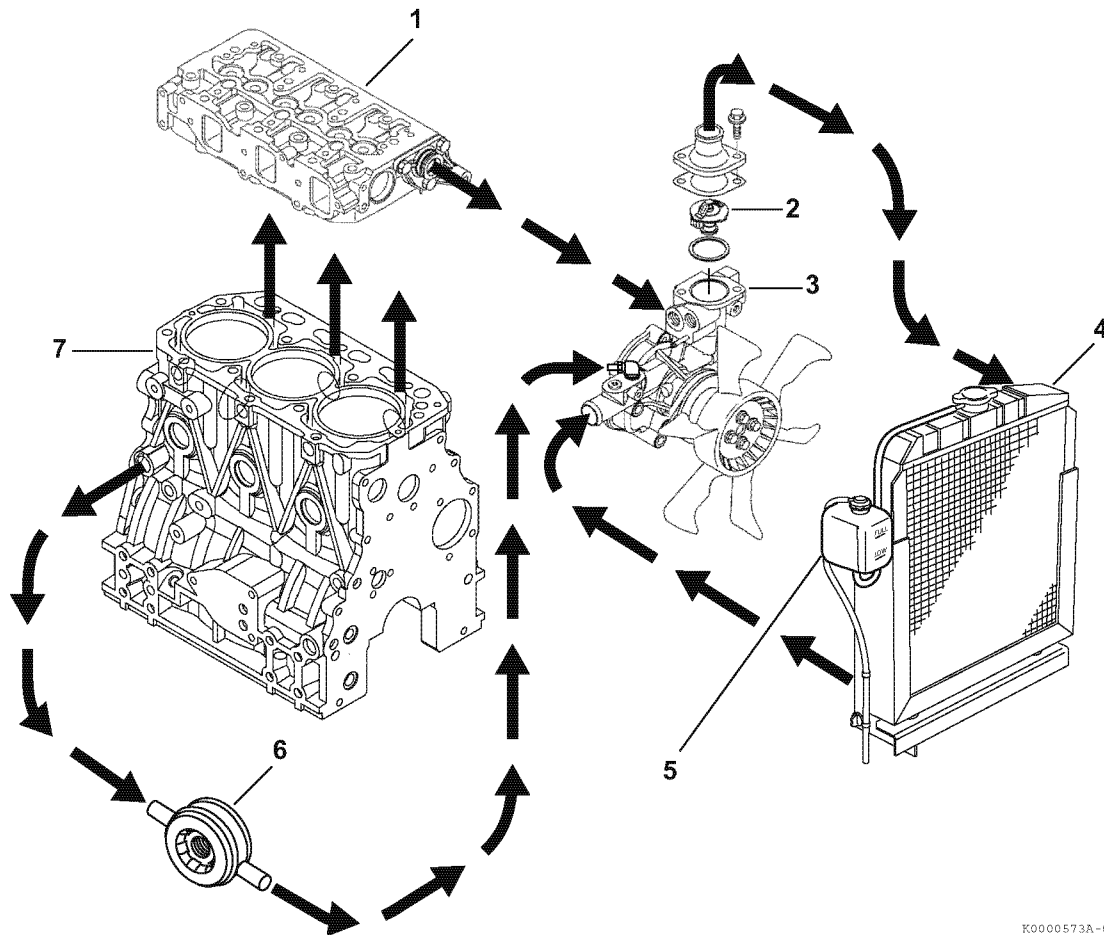

K0000573A-01X

- 1 – Cylinder head
- 2 – Thermostat
- 3 – Engine coolant pump
- 4 – Radiator

- 5 – Coolant recovery tank
- 6 – Engine oil cooler*¹
- 7 – Cylinder block

Figure 8-1

*¹ Not standard on all models.

ENGINE COOLANT PUMP COMPONENTS

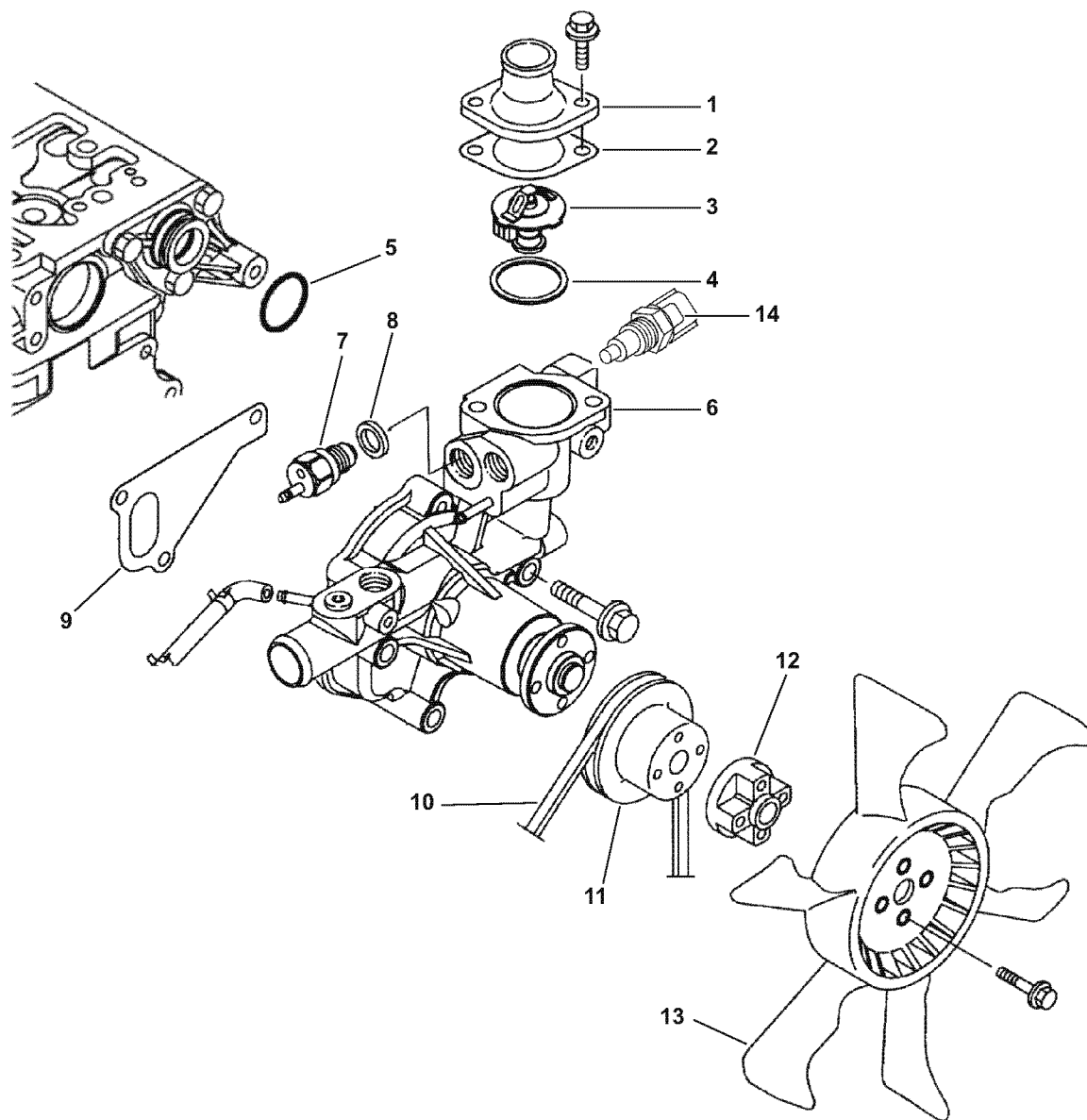

K0000031A-01X

- 1 – Thermostat cover
- 2 – Thermostat cover gasket
- 3 – Thermostat
- 4 – Thermostat O-ring
- 5 – Special O-ring
- 6 – Engine coolant pump
- 7 – Temperature switch
- 8 – Gasket
- 9 – Engine coolant pump gasket
- 10 – V-belt
- 11 – Engine coolant pump V-pulley
- 12 – Spacer
- 13 – Engine coolant fan
- 14 – Water temperature sensor
(Electronically controlled engine)

Figure 8-2

ENGINE COOLANT SYSTEM CHECK

Check the engine coolant system for leakage.

1. With the radiator properly filled, install a cooling system tester (**Figure 8-3, (1)**).

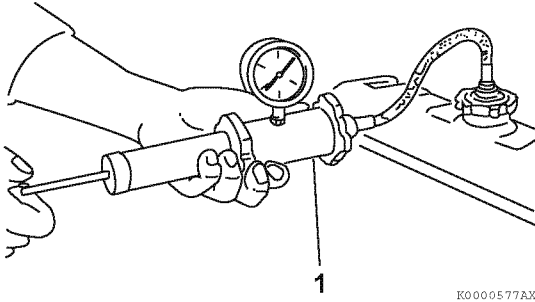

Figure 8-3

2. Apply 10.8 - 14.8 PSI (75 - 105 kPa; 0.75 - 1.05 kgf/cm²) to the cooling system. If the pressure reading drops, the engine coolant system is leaking. Identify the source of the leak and repair it.

ENGINE COOLANT PUMP

Removal of Engine Coolant Pump

Verify the condition of the engine coolant pump before disassembling it from the engine. Check the engine coolant pump shaft bearing for abnormal noise, sticking, excessive play and water leakage. Replace the coolant pump if any of these conditions are present.

CAUTION

Pinch Hazard!



Carefully rotate the alternator toward the cylinder block while loosening the V-belt. Failure to comply may result in minor or moderate injury.

NOTICE

If the engine coolant pump must be replaced, replace the engine coolant pump as an assembly only. Do not attempt to repair the engine coolant pump or replace individual components.

NOTICE

Make sure the engine and engine coolant are not hot.

1. Before removing the engine coolant pump or thermostat, it will be necessary to drain the engine coolant. Drain the coolant into a clean container if the coolant is to be reused. Otherwise, properly dispose of the coolant.
2. Remove the radiator cap (**Figure 8-4, (1)**).
3. Remove the drain plug or open the drain cock (**Figure 8-4, (1)**) at the lower portion of the radiator and drain the coolant.

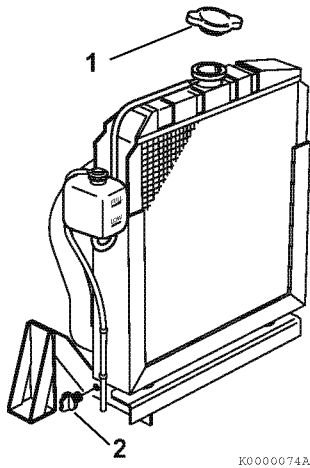

Figure 8-4

4. Drain the coolant from the engine block.
 - On models equipped with an oil cooler, remove the coolant hose (**Figure 8-5, (1)**) at the oil cooler.

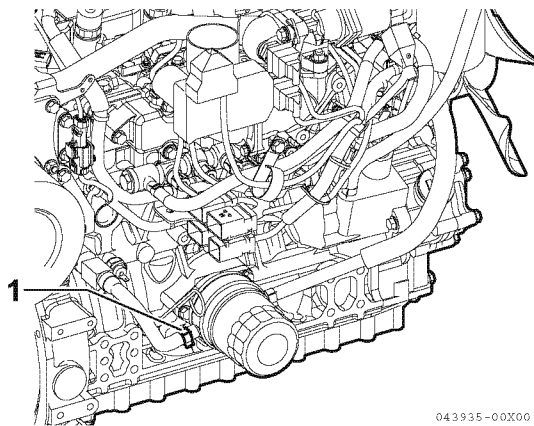

Figure 8-5

- On models not equipped with an oil cooler, remove the coolant drain plug (**Figure 8-6, (1)**) from the engine block.

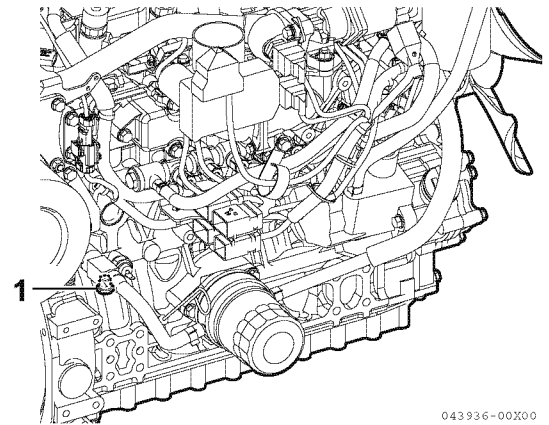

Figure 8-6

5. Loosen the alternator mounting bolts. Loosen and remove the V-belt and rotate the alternator away from the engine and out of the way.
6. Remove the engine coolant fan guard (if equipped), engine coolant fan (**Figure 8-7, (1)**), spacer (**Figure 8-7, (2)**) and engine coolant pump V-pulley (**Figure 8-7, (3)**).

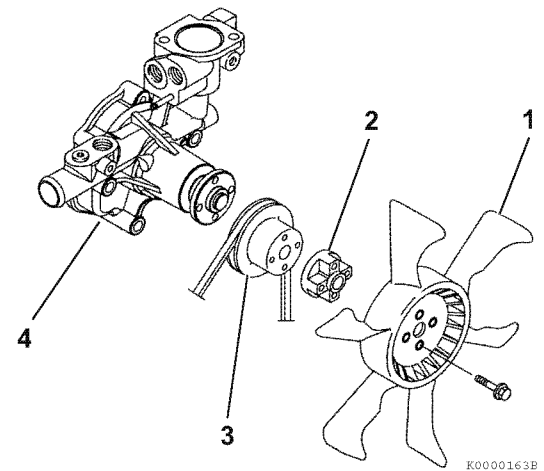

Figure 8-7

7. Disconnect the coolant hoses and the temperature switch lead wire from the engine coolant pump.
8. Remove the engine coolant pump (**Figure 8-7, (4)**). Discard the gasket.

Disassembly of Engine Coolant Pump

1. Remove the thermostat cover (**Figure 8-8, (1)**). Discard the gasket.

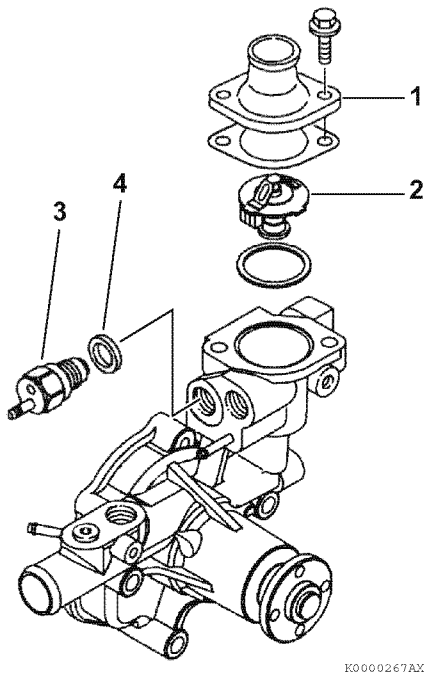

Figure 8-8

2. Remove the thermostat (**Figure 8-8, (2)**). Discard the O-ring. Remove the temperature switch (**Figure 8-8, (3)**) and gasket (**Figure 8-8, (4)**). Discard the gasket.

Cleaning and Inspection

■ Temperature switch

1. Check for proper operation of the temperature switch. Connect a continuity light or ohmmeter to the temperature switch. Connect one lead to the terminal of the switch (**Figure 8-9, (1)**) and the other lead to the metal portion of the switch (**Figure 8-9, (2)**).

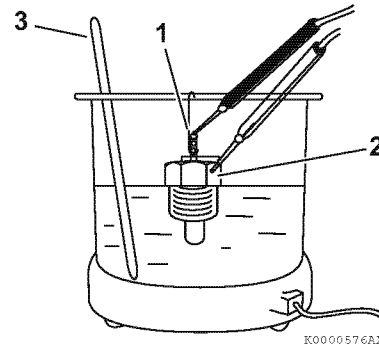

Figure 8-9

2. Place the temperature switch and an accurate thermometer (**Figure 8-9, (3)**) in engine coolant.
3. Slowly increase temperature of the fluid using an external heat source.
4. The temperature switch is operating properly if the continuity light or ohmmeter indicates continuity when the fluid temperature reaches 225 °F - 235 °F (107 °C - 113 °C).

■ Water temperature sensor

1. Inspect the water temperature sensor to make sure that it is properly operating. As shown in the following figure, connect an electric resistor to the coupler of the water temperature sensor (Figure 8-10, (1)).

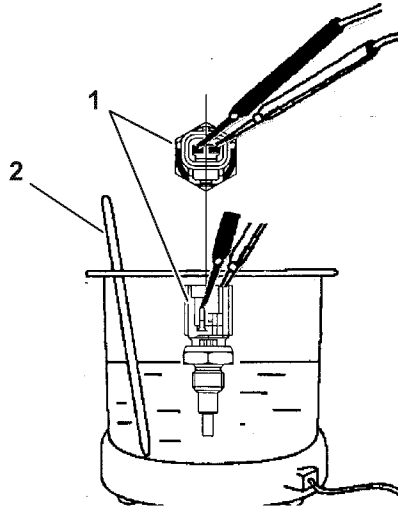

Figure 8-10

2. Dip the water temperature sensor and an accurate thermometer (Figure 8-10, (2)) into the cooling water.
3. Measure the electric resistance value while slowly raising the cooling water temperature using an external heat source.
4. The resistance value at each of the following temperatures is within the permissible range specified, the water temperature sensor is correctly operating.

Cooling water temperature (°C)	Resistance (kΩ)
20	2.45 ^{+0.14} / _{-0.13}
80	0.318 ± 0.008
100	(0.1836)

■ Thermostat

1. Check for proper operation of the thermostat. Place the thermostat (Figure 8-11, (1)) and an accurate thermometer (Figure 8-11, (2)) in warm water.

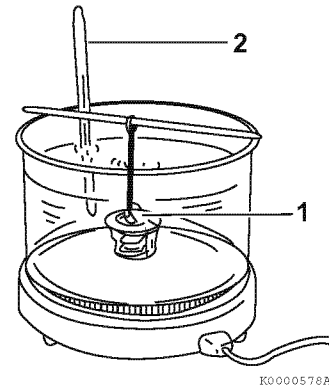

Figure 8-11

2. Slowly increase the temperature of the water using an external heat source.
3. The thermostat is operating properly if it starts to open at the temperature value stamped on the flange of the thermostat, and fully opens as the temperature of the water is increased.

■ Radiator cap

1. Check for proper operation of the radiator cap. Install the radiator cap (Figure 8-12, (1)) on a cooling system tester.

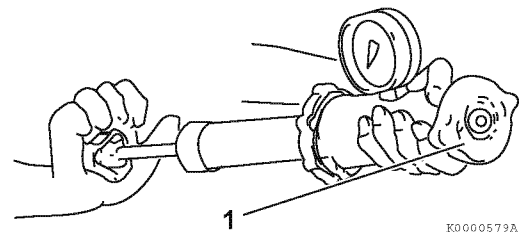

Figure 8-12

2. Apply 10.8 - 14.8 PSI (75 - 105 kPa; 0.75 - 1.05 kgf/cm²) to the radiator cap. The radiator cap relief valve must open within the specified range.

Reassembly of Engine Coolant Pump

1. Reinstall the thermostat (Figure 8-13, (1)) and a new O-ring.

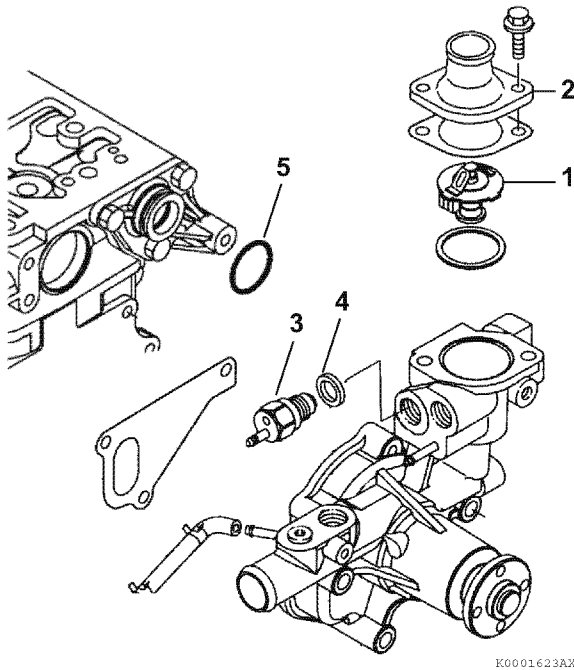

Figure 8-13

2. Reinstall the thermostat cover (Figure 8-13, (2)) and a new gasket. Tighten the thermostat cover bolts.
3. Reinstall the temperature switch (Figure 8-13, (3)) and a new gasket (Figure 8-13, (4)).

Installation of Engine Coolant Pump

1. Position the engine coolant pump on the engine and install a new gasket. Install a new special O-ring (Figure 8-13, (5)) on assembly between the engine coolant pump and the joint.

NOTICE

Use a new special O-ring between the engine coolant pump and the joint. Be sure to use the special O-ring for each engine model. Although the O-ring dimensions are the same as a commercially available O-ring, the material is different.

2. Reinstall the engine coolant pump bolts. Tighten the bolts.
3. Inspect and reinstall the coolant hoses and the temperature switch lead wire.
4. Reinstall the engine coolant pump V-pulley (Figure 8-14, (1)), spacer (Figure 8-14, (2)) engine coolant fan (Figure 8-14, (3)) and engine coolant fan guard (if equipped).

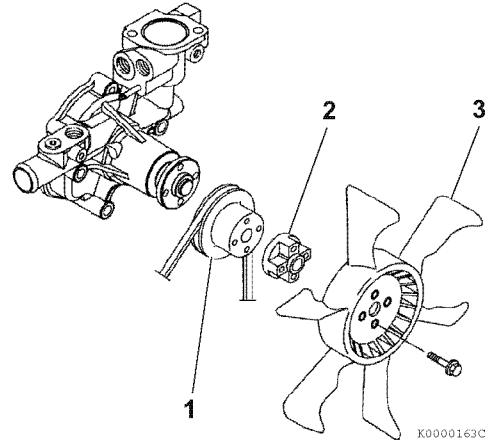

Figure 8-14

5. Inspect the condition of the V-belt. There must be clearance (Figure 8-15, (1)) between the V-belt and the bottom of the pulley groove. If there is no clearance (Figure 8-15, (2)) between the V-belt and the bottom of the pulley groove, replace the V-belt.

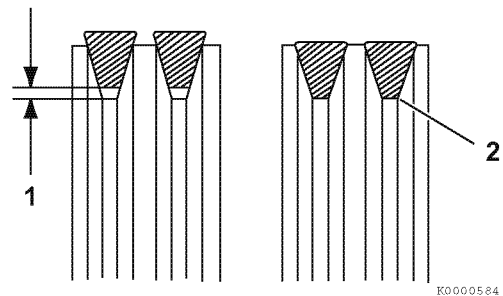

Figure 8-15

6. Reinstall the V-belt. Tighten the V-belt to the proper tension. See *Check and adjust cooling fan V-belt on page 5-15.*
7. Reinstall and tighten the drain plug or close the drain cock in the radiator. Reinstall and tighten the engine block drain plug or reconnect the coolant hose at the oil cooler.

8. Fill the radiator and engine with engine coolant.
See Drain, flush and refill cooling system with new coolant on page 5-19.

NOTICE

- Only use the engine coolant specified. Other engine coolants may affect warranty coverage, cause an internal buildup of rust and scale and/or shorten engine life.
 - Prevent dirt and debris from contaminating the engine coolant. Carefully clean the radiator cap and the surrounding area before you remove the cap.
 - Never mix different types of engine coolants. This may adversely affect the properties of the engine coolant.
-

This Page Intentionally Left Blank

Section 9

LUBRICATION SYSTEM

	Page
Before You Begin Servicing	9-3
Introduction.....	9-4
Oil Pump Service Information.....	9-4
Lubrication System Diagram	9-6
Checking Engine Oil Pressure	9-7
Oil Pump Components	9-7
3TNV88C, 3TNV86CT, 4TNV88C, 4TNV86CT	9-7
Disassembly of Oil Pump	9-8
Cleaning and Inspection	9-8
Reassembly of Oil Pump	9-10
4TNV98C, 4TNV98CT (Trochoid Oil Pump).....	9-11
Disassembly of Oil Pump	9-11
Cleaning and Inspection	9-12
Reassembly of Oil Pump	9-13

This Page Intentionally Left Blank

BEFORE YOU BEGIN SERVICING

Before performing any service procedures within this section, read the following safety information and review the *Safety* section on page 3-1.

INTRODUCTION

This section of the Service Manual describes the procedures necessary to service the 3TNV88C to 4TNV86CT and 4TNV98C/4TNV98CT Trochoid oil pumps.

See *Replace engine oil and engine oil filter* on page 5-14 for engine oil and engine oil filter replacement procedures.

OIL PUMP SERVICE INFORMATION

■ Engine oil pressure

Model	At rated engine RPM						At low idle speed
	1500 - 1800 min ⁻¹	2000 - 2500 min ⁻¹	2600 min ⁻¹	2700 min ⁻¹	2800 min ⁻¹	2900 - 3000 min ⁻¹	
3TNV88C	0.29 - 0.44 MPa (3.0 - 4.5 kgf/cm ²)	0.34 - 0.49 MPa (3.5 - 5.0 kgf/cm ²)			0.39 - 0.54 MPa (4.0 - 5.5 kgf/cm ²)		0.06 MPa (0.6 kgf/cm ²) or greater
4TNV88C	0.29 - 0.44 MPa (3.0 - 4.5 kgf/cm ²)	0.32 - 0.47 MPa (3.3 - 4.8 kgf/cm ²)					
3TNV86CT	0.29 - 0.44 MPa (3.0 - 4.5 kgf/cm ²)	0.34 - 0.49 MPa (3.5 - 5.0 kgf/cm ²)	0.39 - 0.54 MPa (4.0 - 5.5 kgf/cm ²)				
4TNV86CT	0.29 - 0.44 MPa (3.0 - 4.5 kgf/cm ²)	0.36 - 0.51 MPa (3.7 - 5.2 kgf/cm ²)					
4TNV98C, 4TNV98CT	0.29 - 0.39 MPa (3.0 - 4.0 kgf/cm ²)						

■ Outer rotor outside clearance

Model	Standard	Limit	Reference page
3TNV88C, 3TNV86CT, 4TNV88C, 4TNV86CT	0.0035 - 0.0059 in. (0.09 - 0.15 mm)	0.0098 in. (0.25 mm)	<i>Check outer rotor outside clearance on page 9-8</i>
4TNV98C, 4TNV98CT	0.0039 - 0.0061 in. (0.100 - 0.155 mm)	0.0098 in. (0.25 mm)	<i>Check outer rotor outside clearance on page 9-12</i>

■ Outer rotor side clearance

Model	Standard	Limit	Reference page
3TNV88C, 3TNV86CT, 4TNV88C, 4TNV86CT	0.0020 - 0.0035 in. (0.05 - 0.09 mm)	0.0059 in. (0.15 mm)	Check outer rotor side clearance on page 9-9
4TNV98C, 4TNV98CT	0.0020 - 0.0039 in. (0.05 - 0.10 mm)	0.0059 in. (0.15 mm)	Check outer rotor side clearance on page 9-12

■ Outer rotor to inner rotor tip clearance

Model	Standard	Limit	Reference page
3TNV88C, 3TNV86CT, 4TNV88C, 4TNV86CT	—	0.0063 in. (0.16 mm)	Outer rotor to inner rotor tip clearance on page 9-9
4TNV98C, 4TNV98CT	—	0.0063 in. (0.16 mm)	Outer rotor to inner rotor tip clearance on page 9-12

■ Rotor shaft clearance

Model	Inspection item	Standard	Limit	Reference page
3TNV88C, 3TNV86CT, 4TNV88C, 4TNV86CT	Plate bearing I.D.	0.3945 - 0.3952 in. (10.020 - 10.038 mm)	0.3962 in. (10.063 mm)	Check rotor shaft clearance on page 9-9
	Rotor shaft O.D.	0.3928 - 0.3932 in. (9.978 - 9.987 mm)	0.3922 in. (9.963 mm)	
	Rotor clearance	0.0013 - 0.0024 in. (0.033 - 0.060 mm)	0.0039 in. (0.100 mm)	
4TNV98C, 4TNV98CT	Gear case bearing I.D.	0.5110 - 0.5126 in. (12.980 - 13.020 mm)	0.5138 in. (13.050 mm)	Check rotor shaft clearance on page 9-13
	Rotor shaft O.D.	0.5100 - 0.5104 in. (12.955 - 12.965 mm)	0.5096 in. (12.945 mm)	
	Rotor clearance	0.0006 - 0.0026 in. (0.015 - 0.065 mm)	0.0041 in. (0.105 mm)	

LUBRICATION SYSTEM DIAGRAM

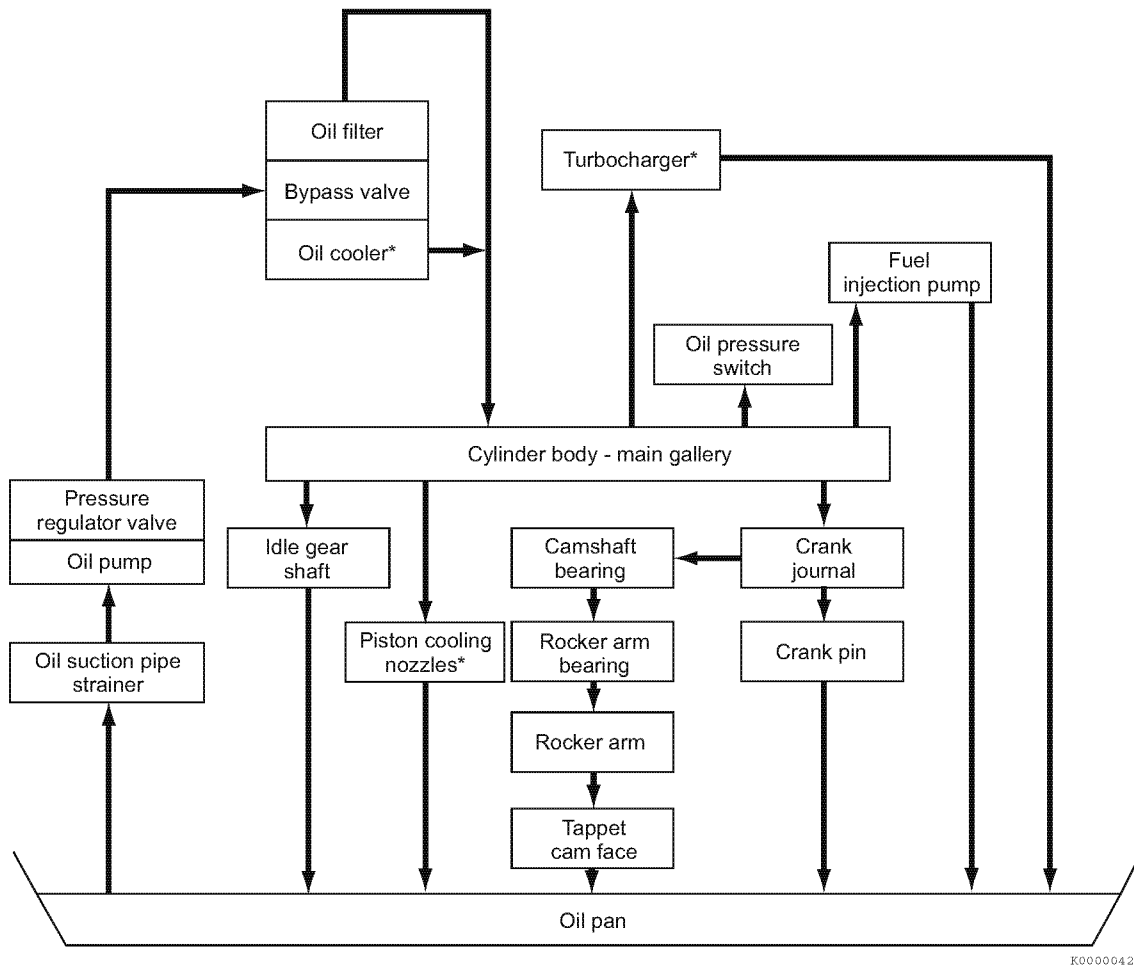

Figure 9-1

Note: Items marked* are not standard equipment on all models.

CHECKING ENGINE OIL PRESSURE

Perform an engine oil pressure check if there is any indication of low oil pressure such as the oil pressure indicator is on or the oil pressure gauge indicates low oil pressure. See *Engine oil pressure* on page 9-4.

1. Disconnect the wire lead from the oil pressure switch or sending unit (**Figure 9-2, (1)**).

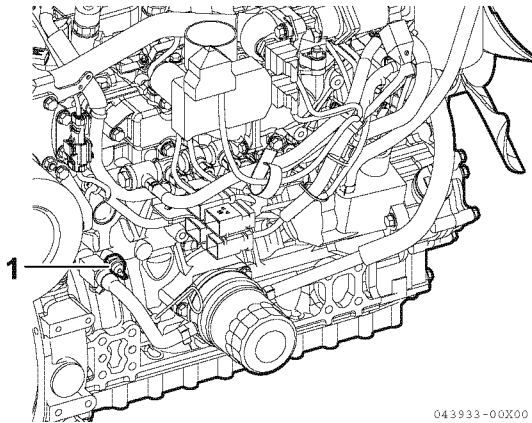

Figure 9-2

2. Remove the oil pressure switch.
3. Install a mechanical oil pressure gauge in the oil pressure switch port.
4. Start the engine:
 - If the mechanical oil pressure test gauge indicates good oil pressure, replace the faulty oil pressure switch or sending unit, or faulty machine oil pressure gauge in instrument panel.
 - If the mechanical oil pressure test gauge indicates low oil pressure, troubleshoot the lubrication system to locate the cause of the low oil pressure. See *Failure Diagnostic List* on page 15-7. Repair as necessary.

OIL PUMP COMPONENTS

3TNV88C, 3TNV86CT, 4TNV88C, 4TNV86CT

The oil pump on these model engines is located in the front gear case and is driven by the same gear train that drives the camshaft and fuel injection pump. You must remove the front gear case cover to gain access to the oil pump.

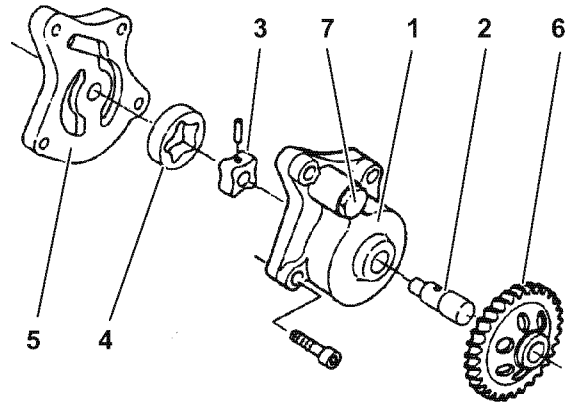

- 1 – Body
- 2 – Shaft
- 3 – Inner rotor
- 4 – Outer rotor
- 5 – Cover
- 6 – Drive gear
- 7 – Pressure regulator valve

Figure 9-3

Disassembly of Oil Pump

NOTICE

If the oil pump must be replaced, replace it as an assembly only. Do not replace individual components.

1. Remove the cooling water fan guard (if equipped), cooling fan (**Figure 9-4, (3)**), spacer (**Figure 9-4, (2)**), cooling water pump V-pulley (**Figure 9-4, (1)**), and V-belt.

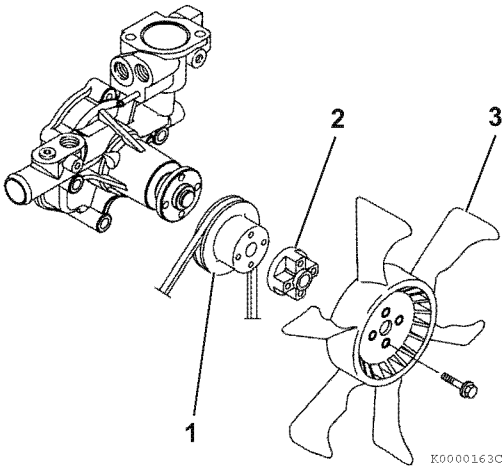

Figure 9-4

2. Remove the crank shaft pulley and gear case cover. See *Removal of timing gear case cover* on page 6-44.
3. Remove the lubricating oil pump assembly mounting bolts. Remove the lubricating oil pump assembly (**Figure 9-5, (1)**) from the gear case flange (**Figure 9-5, (2)**).
4. You can remove by hand the lubricating oil pump cover (**Figure 9-3, (5)**) and outer rotor (**Figure 9-3, (4)**).

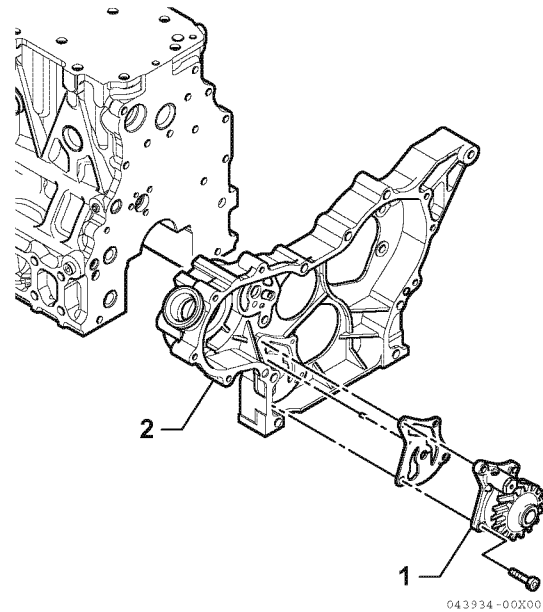

Figure 9-5

Cleaning and Inspection

Clean the lubricating oil pump, pressure regulator valve (**Figure 9-3, (7)**), and rotor inserting portion. Check the parts for wear or flaw. Replace the parts with new ones as needed.

NOTICE

- Never overfill the engine with engine oil.
- Always keep the oil level between the upper and lower lines on the oil cap/dipstick.

Check outer rotor outside clearance

Inspect the outside diameter clearance of the outer rotor. To inspect this, insert a feeler gauge between the outer rotor (**Figure 9-6, (1)**) and the lubricating oil pump body (**Figure 9-6, (2)**).

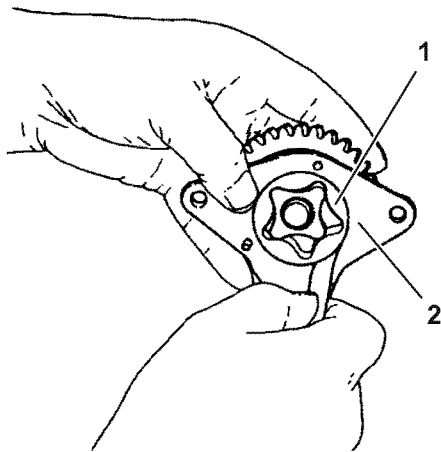

Figure 9-6

Record the measurement(s) and see *Outer rotor outside clearance* on page 9-4 for the service limits.

■ Outer rotor to inner rotor tip clearance

Inspect the tip clearance between the outer and inner rotors. To inspect this, insert a feeler gauge between the inner rotor tooth tip (**Figure 9-7, (1)**) and the outer rotor tooth tip (**Figure 9-7, (2)**), and measure the clearance.

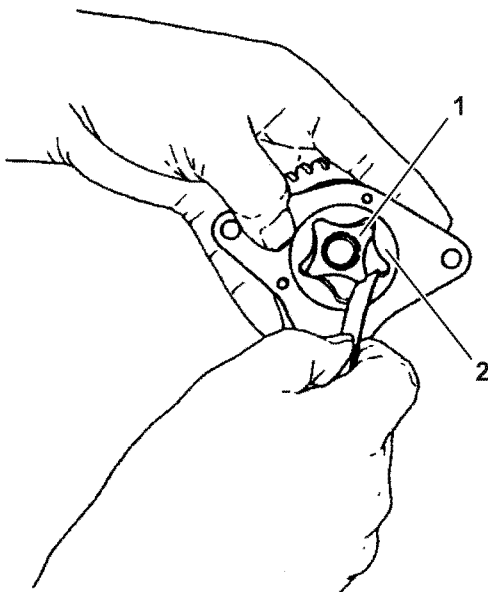

Figure 9-7

Record the measurement(s) and see *Outer rotor to inner rotor tip clearance* on page 9-5 for the service limits.

■ Check outer rotor side clearance

Inspect the side clearance between the lubricating oil pump body and the outer rotor. To measure the side clearance, use a straight edge and feeler gauge (as shown in **Figure 9-8**) or a depth micrometer.

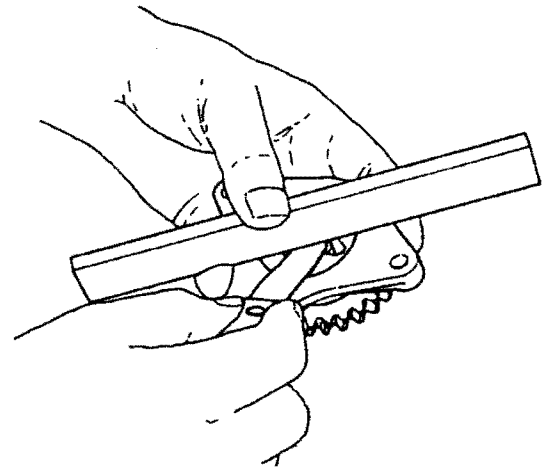

Figure 9-8

Record the measurement(s) and see *Outer rotor outside clearance* on page 9-4 for the service limits.

■ Check rotor shaft clearance

Inspect the rotor shaft clearance. Measure the outside diameter of the rotor shaft (**Figure 9-9, (1)**) and the inside diameter of the cover.

Determine the clearance by subtracting the outside diameter of the rotor from the inside diameter of the cover.

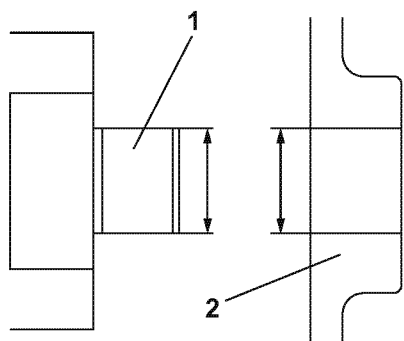

Figure 9-9

Record the measurement(s) and see Rotor shaft clearance on page 9-5 for the service limits.

Reassembly of Oil Pump

1. Apply clean lubricating oil to the lubricating oil pump body and inner rotor assembly as well as to the outer rotor.
2. Insert the outer rotor into the lubricating oil pump body and inner rotor assembly and install the cover.
3. Replace the packing with new one.
4. Install the lubricating oil pump assembly to the gear case by tightening the bolts with the specified torque.
5. Install the gear case cover. For more information, See Installation of gear case cover on page 6-65.
6. Install the crank shaft pulley.
7. Install the cooling water pump V-pulley (**Figure 9-10, (1)**), spacer (**Figure 9-10, (2)**), cooling water fan (**Figure 9-10, (3)**), and fan guard (if equipped).

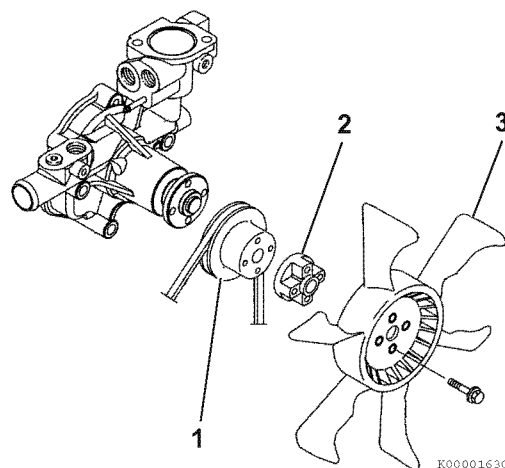
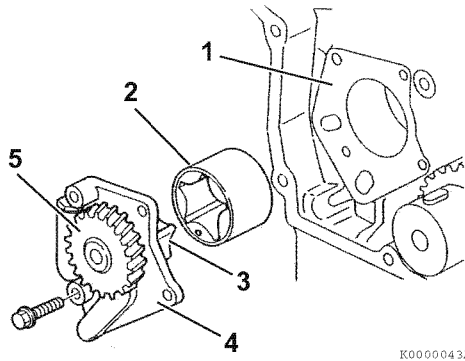

Figure 9-10

8. Install the V-belt. Adjust the belt to uniform tensile strength in accordance with the instructions given in *Check and adjust cooling fan V-belt* on page 5-9.

4TNV98C, 4TNV98CT (Trochoid Oil Pump)

The oil pump on these model engines is located in the front gear case and is driven by the same gear train that drives the camshaft and fuel injection pump. You must remove the front gear case cover to gain access to the oil pump.



- 1 – Gear case housing
- 2 – Outer rotor
- 3 – Inner rotor
- 4 – Cover plate
- 5 – Drive gear

Figure 9-11

Disassembly of Oil Pump

NOTICE

If the oil pump must be replaced, replace it as an assembly only. Do not replace individual components.

Remove the engine cooling fan guard (if equipped), engine cooling fan (**Figure 9-12, (3)**), spacer (**Figure 9-12, (2)**), engine coolant pump V-pulley (**Figure 9-12, (1)**) and V-belt.

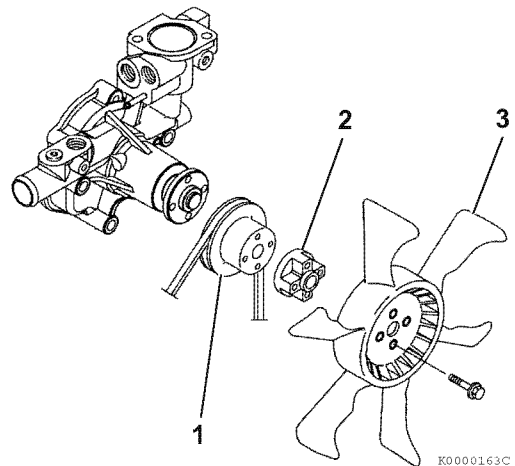

Figure 9-12

1. Remove the crankshaft pulley and the gear case cover. See *Removal of timing gear case cover* on page 6-44.
2. Remove the oil pump assembly bolts. Remove the oil pump assembly (**Figure 9-13, (1)**) from the gear case housing (**Figure 9-13, (2)**).

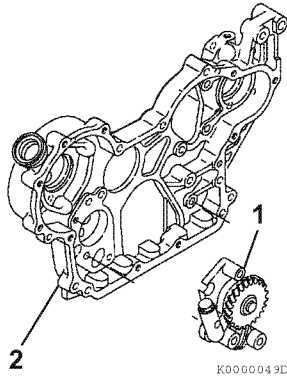

Figure 9-13

Cleaning and Inspection

Wash the oil pump, oil pressure regulator and oil pump cavity. Inspect for wear or damage. Replace as necessary.

NOTICE

If any oil pump component clearance exceeds its limit, the oil pump must be replaced as an assembly.

■ Check outer rotor outside clearance

Determine the outside clearance of the outer rotor. Insert a feeler gauge between the outer rotor (Figure 9-14, (1)) and gear case oil pump cavity (Figure 9-14, (2)).

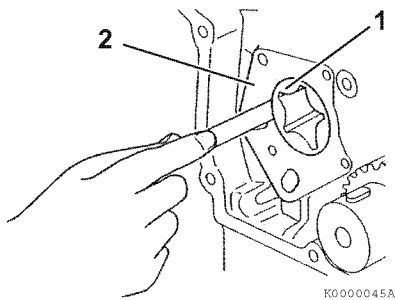

Figure 9-14

Record the measurement(s) and see Check outer rotor outside clearance on page 9-8 for the service limits.

■ Outer rotor to inner rotor tip clearance

Determine the outer rotor to inner rotor tip clearance. Insert a feeler gauge between the top of an inner rotor tooth (Figure 9-15, (1)) and the top of an outer rotor tooth (Figure 9-15, (2)) and measure the clearance.

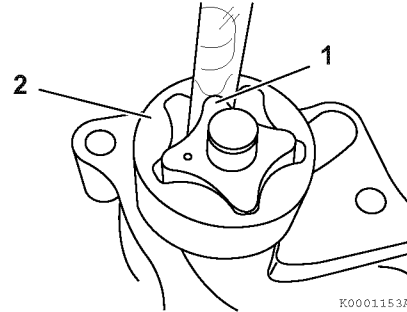

Figure 9-15

Record the measurement(s) and see Outer rotor to inner rotor tip clearance on page 9-5 for the service limits.

■ Check outer rotor side clearance

Determine the side clearance of the outer rotor across the pump cavity. Measure the depression using a depth micrometer (Figure 9-16, (1)).

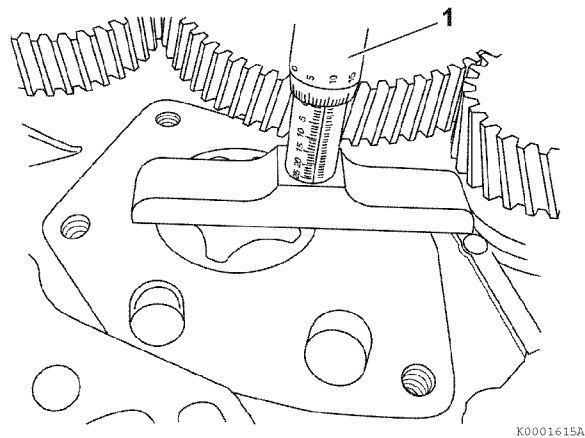

Figure 9-16

Record the measurement(s) and see Check outer rotor outside clearance on page 9-8 for the service limits.

Check rotor shaft clearance

Determine the rotor shaft clearance. Measure the outside diameter of the rotor shaft (Figure 9-17, (1)) and the bore diameter in the gear case housing (Figure 9-17, (2)).

Calculate the difference between the two measurements to determine the clearance.

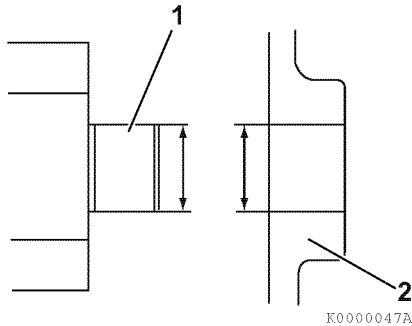

Figure 9-17

Record the measurement(s) and see Rotor shaft clearance on page 9-5 for the service limits.

Reassembly of Oil Pump

1. Lubricate the outer rotor and pump bore in the gear case with clean engine oil.
2. Reinstall the outer rotor in the gear case housing. The punch mark (Figure 9-18, (1)) on the end of the outer rotor must face away from the gear case housing (Figure 9-18, (2)).

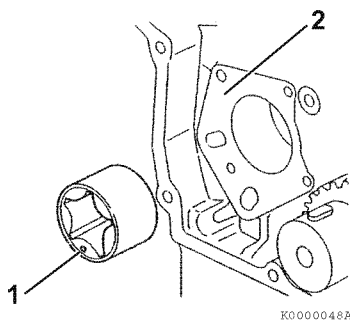

Figure 9-18

3. Reinstall the oil pump assembly (Figure 9-19, (1)) into the gear case housing (Figure 9-19, (2)). Tighten the bolts to specified torque.

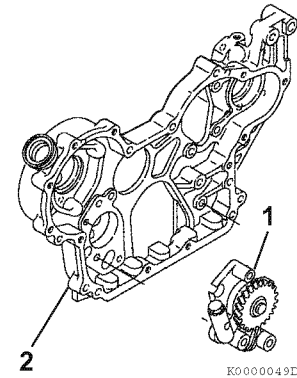

Figure 9-19

4. Reinstall the gear case cover and crankshaft pulley. See Installation of gear case cover on page 6-65.
5. Reinstall the engine coolant pump V-pulley (Figure 9-20, (1)), spacer (Figure 9-20, (2)), engine cooling fan (Figure 9-20, (3)) and engine cooling fan guard (if equipped).

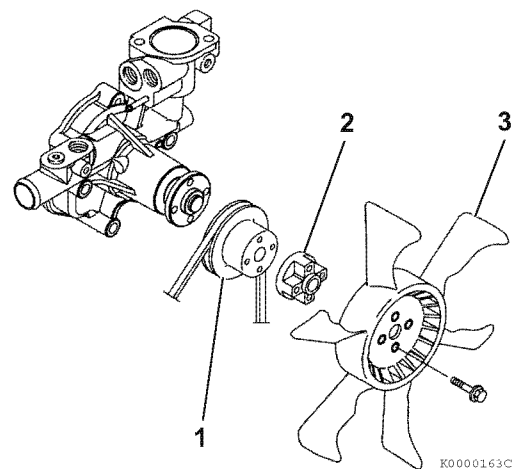

Figure 9-20

6. Reinstall the V-belt. Tighten the V-belt to the proper tension as described in Check and adjust cooling fan V-belt on page 5-9.

This Page Intentionally Left Blank

Section 10

TURBOCHARGER

	Page
Before You Begin Servicing	10-3
Introduction.....	10-4
Specifications	10-4
Turbocharger Service Information	10-4
Troubleshooting.....	10-5
Turbocharger Components	10-7
Turbocharger Component Functions.....	10-8
Theory of Operation.....	10-9
Compressor Side Sealing Mechanism	10-9
Waste Gate Modulation	10-9
Washing Procedure.....	10-10
Periodic Inspection	10-11
Visual Inspection	10-11
Inspection of Rotor Rotation.....	10-11
Inspection of Rotor Play	10-11
Removal of Turbocharger.....	10-11
Waste Gate Valve Test.....	10-13
Waste Gate Actuator Leak Test	10-13
Installation of Turbocharger.....	10-13

This Page Intentionally Left Blank

BEFORE YOU BEGIN SERVICING

Before performing any service procedures within this section, read the following safety information and review the *Safety* section on page 3-1.

INTRODUCTION

This section of the Service Manual describes the servicing of the RHF3, RHF4 and RHF5 model turbochargers.

SPECIFICATIONS

Turbocharger Service Information

Applicable engine model (application)	3TNV86CT	4TNV86CT	4TNV98CT
Turbocharger model	RHF3	RHF4	RHF5
Turbocharger specification	Standard (w/waste gate)		
Turbine type	Radial flow		
Blower (compressor) type	Centrifugal		
Lubrication	External lubrication		
Maximum continuous allowable speed	250,000	190,000	180,000
Maximum continuous allowable gas inlet temperature	750 °F (399 °C)		
Weight (Dry)	5.4 lb (24 N; 2.4 kgf)	5.7 lb (25 N; 2.6 kgf)	10.3 lb (46 N; 4.7 kgf)

Note: VM application is provided with the waste gate.

TROUBLESHOOTING

The following troubleshooting procedures apply to problems identified as turbocharger related. Consider all other troubleshooting possibilities before cleaning or removing the turbocharger.

■ Excessive exhaust smoke

Cause	Corrective action
Clogged air cleaner element Blocked air intake port Leak from a joint in intake line	Clean or replace the air cleaner element Correct the condition Correct the condition

Cause	Corrective action
<ol style="list-style-type: none"> 1. Compressor impeller dirty 2. Deposit of impurities in oil sticking on the turbine side seal portion to make turbine revolution heavy 3. Sticking bearing: <ul style="list-style-type: none"> • Insufficient lubrication or clogged lubrication piping • Excessively high oil temperature • Unbalanced rotating part • Insufficient warming up or sudden stop from loaded operation (no-load operation) 4. Contact or breakdown of turbine wheel or blower vane: <ul style="list-style-type: none"> • Excessive revolution • Excessive exhaust temperature rise • Foreign matter within turbocharger • Worn bearing • Incorrect assembly of turbocharger 	<ol style="list-style-type: none"> 1. Wash the impeller blades. 2. Repair the turbocharger. Send to a qualified repair facility. 3. <ul style="list-style-type: none"> • Repair turbocharger. Send to qualified repair facility. • Inspect the lubricating oil line for problem. Correct the condition and replace lubricating oil. • Repair the turbocharger. Send to a qualified repair facility. • Improper operation of the machine. Refer to the Inspection and repair of each engine part 4. <ul style="list-style-type: none"> • Inspection and repair of each engine part • Inspection and repair of each engine part • Clean the air cleaner and engine compartment. Repair the turbocharger. Send to a qualified repair facility. • Repair the turbocharger. Send to a qualified repair facility. • Repair the turbocharger. Send to a qualified repair facility.

Cause	Corrective action
Exhaust system gas leak prior to the turbocharger. Condition will decrease turbocharger revolutions. Deformed or clogged exhaust pipe. Condition will decrease turbocharger revolutions.	Inspect the exhaust system for leaks. Correct the condition. Correct the condition.

■ **Generates white smoke**

Cause	Corrective action
Clogged or deformed oil return pipe causing oil flow to the blower on the turbine side Excessive bearing wear causing abnormal wear or damage of the seal ring	Correct the condition Repair the turbocharger. Send to a qualified repair facility.

■ **Sudden oil decrease**

Cause	Corrective action
Excessive bearing wear causing abnormal wear or damage of the seal ring	Repair turbocharger. Send to qualified repair facility.

■ **Decrease in output**

Cause	Corrective action
Gas leak from any part in exhaust piping Air leak from discharge side of blower Clogged air cleaner element Damaged turbocharger	Correct the condition Correct the condition Clean or replace the air cleaner element Repair the turbocharger. Send to a qualified repair facility

■ **Poor (slow) response (starting) of turbocharger**

Cause	Corrective action
Hard carbon deposit on the turbine side (wheel sealing portion) causing abnormal revolution of the turbine shaft Incomplete combustion	Repair the turbocharger. Send to a qualified repair facility Correct the condition

■ **Abnormal sound or vibration**

Cause	Corrective action
Excessively narrowed gas path due to clogged nozzle in the turbine wheel chamber or reverse flow of blower discharge in acceleration (generally called surging) Contact rotating part	Repair the turbocharger. Send to a qualified repair facility Repair the turbocharger. Send to a qualified repair facility

Cause	Corrective action
Loosened intake, exhaust or oil pipe connection with the turbocharger Damaged bearing, contact between rotating part and adjacent part, or chipping of the turbine wheel or blower vane due to foreign matter within the turbocharger Unbalanced rotating part	Correct the condition Repair the turbocharger. Send to a qualified repair facility Repair the turbocharger. Send to a qualified repair facility

TURBOCHARGER COMPONENTS

Note: The following illustration is provided for informational purposes only. YANMAR does not offer individual service parts for turbochargers. If the turbocharger is worn or damaged, it should be replaced or repaired by a qualified repair facility.

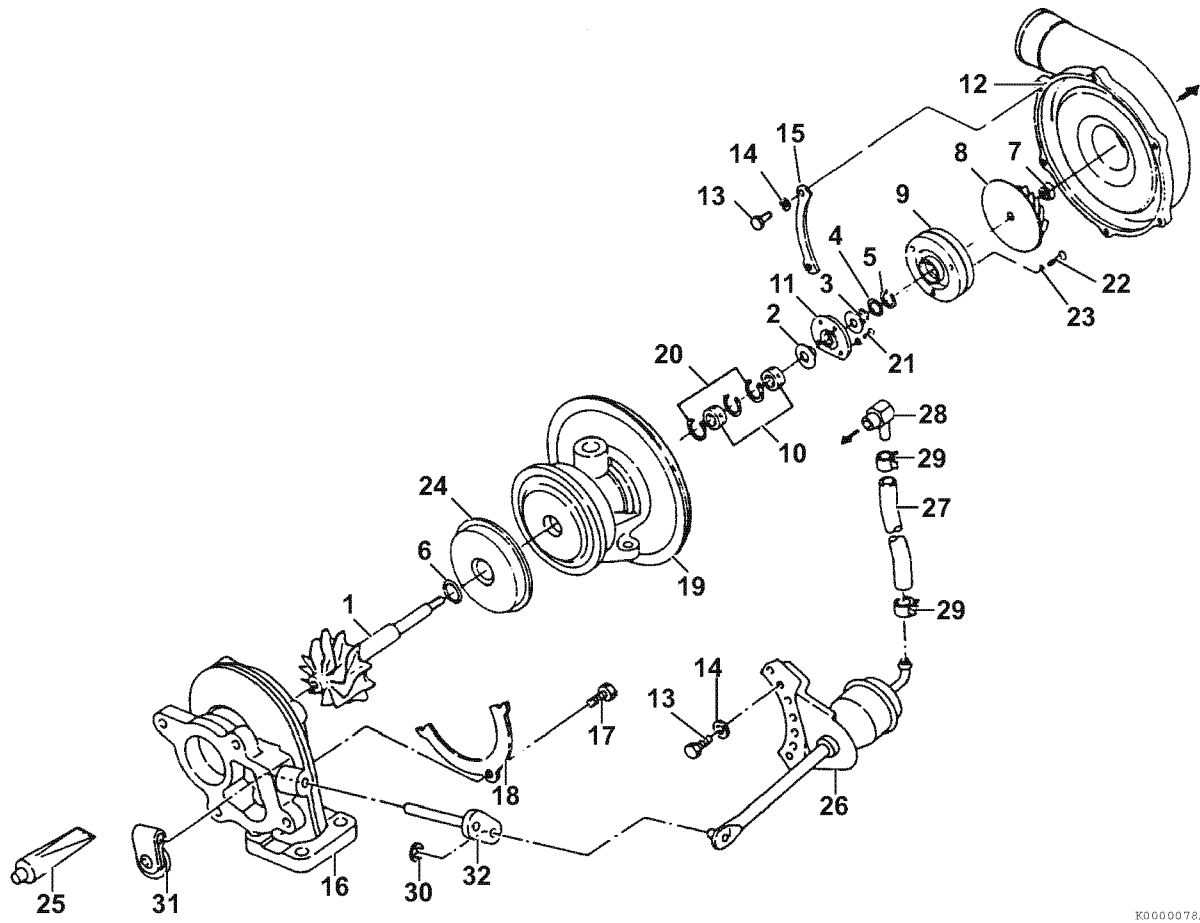

K0000078A

- | | |
|------------------------------|--------------------------|
| 1 – Turbine shaft | 17 – Bolt |
| 2 – Thrust bearing | 18 – Lock plate |
| 3 – Oil thrower | 19 – Bearing housing |
| 4 – Seal ring | 20 – Retaining ring |
| 5 – Seal ring | 21 – Bolt |
| 6 – Seal ring (Turbine side) | 22 – Bolt |
| 7 – Lock nut | 23 – Lock washer |
| 8 – Impeller | 24 – Heat protector |
| 9 – Seal plate | 25 – Liquid gasket |
| 10 – Journal bearing | 26 – Waste gate actuator |
| 11 – Thrust bearing | 27 – Hose |
| 12 – Compressor housing | 28 – Adapter |
| 13 – Flanged bolt | 29 – Clip |
| 14 – Spring washer | 30 – Retaining ring |
| 15 – Clamp | 31 – Waste gate valve |
| 16 – Turbine housing | 32 – Link plate |

Figure 10-1

TURBOCHARGER COMPONENT FUNCTIONS

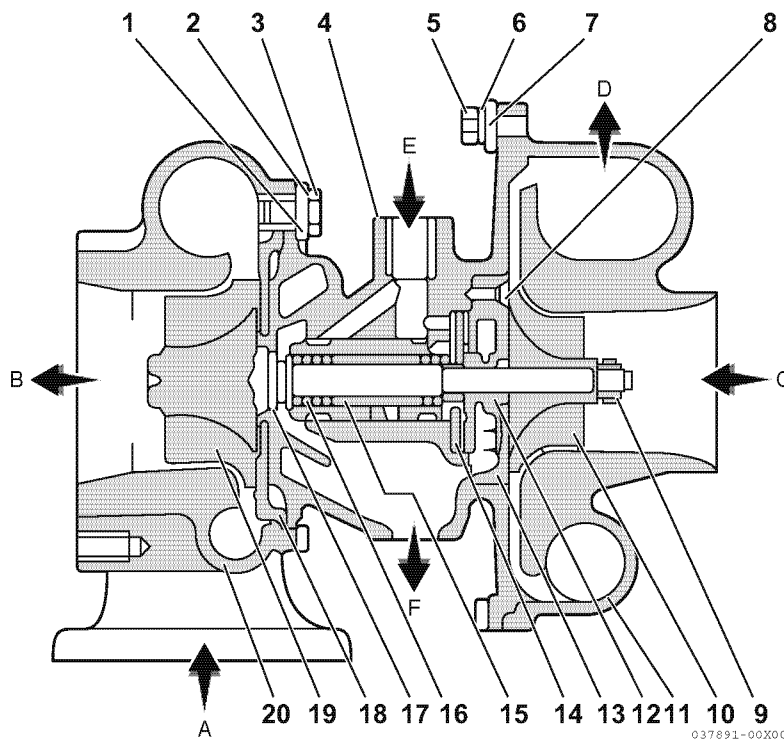

- | | |
|-----------------------------------|-----------------------------|
| 1 – Turbine side clamp | 11 – Oil thrower |
| 2 – Lock washer | 12 – Compressor housing |
| 3 – M6 hex bolt | 13 – Seal plate |
| 4 – Bearing housing | 14 – Thrust bearing |
| 5 – M5 hex bolt | 15 – Retaining ring |
| 6 – M5 spring washer | 16 – Journal bearing |
| 7 – Compressor side clamp | 17 – Turbine side seal ring |
| 8 – M3 countersunk flat-head bolt | 18 – Heat protector |
| 9 – Shaft end nut | 19 – Shaft end nut |
| 10 – compressor wheel | 20 – Turbine shaft |

- | | |
|-----------------------|---------------|
| A. Exhaust gas inlet | D. Air outlet |
| B. Exhaust gas outlet | E. Oil inlet |
| C. Air inlet | F. Oil outlet |

Figure 10-2

Theory of Operation

Normally aspirated engines produce horsepower that is limited by the atmospheric pressure of the induction air. The turbocharger is an exhaust gas pressure driven device that adds to the atmospheric pressure, resulting in a boost in pressure at the combustion chambers. This substantially increases the amount of fuel that can be injected into the combustion chambers, while maintaining the proper fuel-to-air ratio. A slight parasitic loss is imposed on the engine because of added back pressure in the exhaust system. That loss is offset by horsepower gains. The net result is substantially increased overall horsepower over normally aspirated engines.

The turbocharger consists of two main components:

- Turbine
- Compressor

■ Turbine

The turbine is driven by exhaust gas pressure from the engine and is coupled to a shaft on the compressor side of the turbocharger.

Exhaust gas velocity is accelerated at the nozzle portion in the turbine housing where the cross-sectional area is reduced. As exhaust passes over the turbine impeller at high linear velocity, the turbine shaft is rotated at proportionally high rpm.

■ Compressor

The compressor is driven by a shaft on the turbine side of the turbocharger and increases the induction air pressure at the intake manifold.

The compressor impeller draws induction air into the turbocharger, compresses it and directs it into the engine at high pressure.

A seal ring and heat insulating plate thermally isolate heat energy, at the turbine side, from the bearings and the induction air, at the compressor side.

■ Bearings

Thrust bearing

A thrust force is continuously imposed on the turbine shaft during engine operation. A thrust bearing prevents the shaft from moving laterally under this thrust force.

Radial bearing

A floating radial bearing moves with the turbine shaft as oil films form on the inside and outside bearing surfaces. The bearing slipping speed is slower than the turbine shaft speed, resulting in higher dynamic stability and reduced mechanical noise.

Lubrication

The oil pump delivers oil from the engine to the turbocharger for cooling and lubrication of the bearings. As oil leaves the turbocharger, it is returned to the engine.

Compressor Side Sealing Mechanism

A seal ring and a seal plate form a double wall structure at the rear of the compressor impeller. The seal ring and seal plate prevent intake air and oil leakage.

Waste Gate Modulation

Excessive boost pressure that cannot be accommodated by the engine can damage the turbocharger. The waste gate is a component that monitors intake boost pressure on the compressor side and diverts exhaust gases around the turbocharger turbine. The amount of exhaust gas diverted is varied to limit turbine rpm and maintain the intake pressure equal to, or less than the specified maximum level. This improves the response to load variation in the low to medium rpm range and minimizes black smoke.

■ Waste gate control

A mechanical pressure sensor in the outlet of the compressor side of the turbocharger opens and closes the waste gate to maintain the specified intake pressure at the intake manifold.

WASHING PROCEDURE

Note: Inspection, cleaning and repair of the internal turbocharger components must be performed by a qualified repair facility.

The washing procedure described in this section is intended to clean the impeller on the compressor only if the engine loses rpm, seems sluggish or has insufficient boost pressure. The process does not require disassembling any portion of the turbocharger.

Since washing is quick and easy, perform this procedure before considering replacement.

1. Start the engine and allow it to reach the normal operating temperature.

NOTICE

Avoid damage to the turbocharger or the engine. Do not spray blower wash fluid or water too quickly.

Use short strokes from a spray bottle to inject blower wash fluid or water into the turbocharger.

Spraying too much wash fluid or water, or spraying too quickly will damage the turbocharger.

2. While the engine is operating at normal load (75 - 80 % of maximum), slowly and evenly spray 2 - 3 oz (60 - 90 cc) of blower wash fluid over a period of ten to fifteen seconds into the air inlet (**Figure 10-3**).

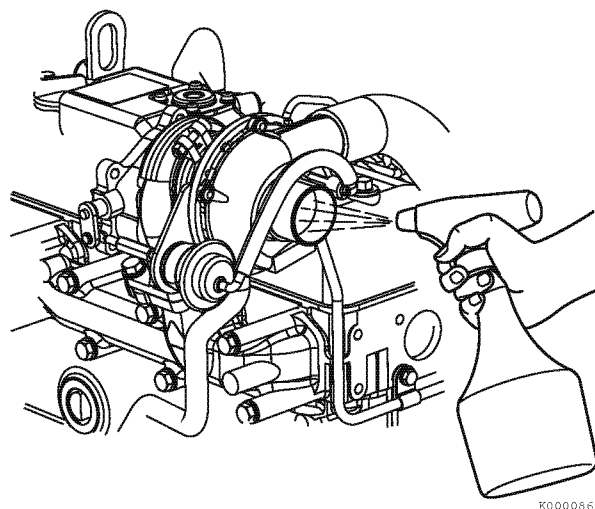

Figure 10-3

3. Continue to operate the engine under the same load for three to four minutes.
4. While the engine is still operating at normal load (75 - 80 % of maximum), slowly and evenly spray 2 - 3 oz (60 - 90 cc) of clean water over a period of ten to fifteen seconds into the air inlet.
5. Continue to operate the engine under the same load for at least ten minutes to completely dry the air intake system and turbocharger.
6. Test the engine performance. If engine performance has not improved, repeat steps 2 through 6. If the engine performance does not improve after executing the washing process three times, replace the turbocharger or have it repaired by a qualified repair facility.

PERIODIC INSPECTION

Inspect the turbocharger at regularly scheduled intervals (for reference).

Visual Inspection

1. Check for indications of oil leaks at the oil inlet and outlet lines. Repair or replace the oil lines as needed.
2. Inspect the air inlet connection to the turbocharger's turbine side for cracks or broken hardware. Repair or replace the connection as needed.
3. Inspect the exhaust outlet connection to the turbocharger's compressor side for cracks or broken hardware. Repair or replace the connection as needed.

Inspection of Rotor Rotation

1. With the engine cool and not operating, manually rotate the rotor. Smooth rotation is normal. Any catching or resistance to rotation is an indication of abnormal operation. Replace the turbocharger or have it repaired by a qualified repair facility.
2. Start the engine.
3. After the engine reaches normal operating temperature, place a stethoscope firmly against the turbocharger case.
4. Increase the rpm gradually. A high-pitched sound, occurring at intervals of two or three seconds, is an indication of abnormal operation. Replace the turbocharger or have it repaired by a qualified repair facility.

Inspection of Rotor Play

To inspect the rotor, the turbocharger must be removed. Inspect for maximum rotor end play and run-out limits before reinstalling.

Removal of Turbocharger

1. Shut down the engine and allow the turbocharger to cool. Remove the exhaust outlet connection from the turbocharger housing.
2. Remove the air inlet connection from the turbocharger housing.

NOTICE

Do not allow any material to fall into the oil lines or the oil inlet and outlet ports of the turbocharger.

3. Remove the inlet and outlet oil lines from the turbocharger. Plug the lines and ports with tape to prevent contamination. Discard the sealing washers and O-rings. Inspect the oil lines and replace if damaged.
4. Remove the turbocharger mounting nuts from the mounting studs. Lift the turbocharger from the engine and place it on a clean, level working surface.
5. Discard the turbocharger exhaust manifold gasket.

Checking Rotor Play

Note: If rotor play measurements are not within specification, replace the turbocharger assembly or have it repaired by a qualified facility.

in. (mm)

Rotor play	Standard dimension		Wear limit	
	RHF4	RHF5	RHF4	RHF5
End play	0.0010 - 0.0033 (0.026 - 0.084)	0.0011 - 0.0024 (0.03 - 0.06)	0.0035 (0.09)	0.0035 (0.09)
Run-out	0.0031 - 0.0051 (0.08 - 0.13)	0.0031 - 0.0051 (0.08 - 0.13)	0.0063 (0.16)	0.0067 (0.17)

■ To check rotor end play:

1. Set up a dial indicator as shown (**Figure 10-4**).
2. Manually move the rotor end-to-end while observing indicated readings. Replace the turbocharger if end play measurements are outside specified limits. *See table above.*

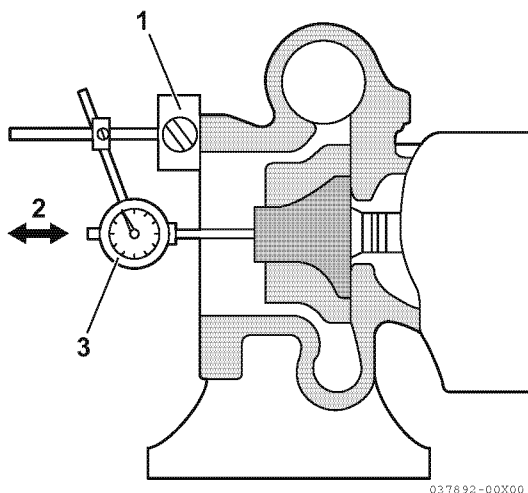

Figure 10-4

■ To check rotor run-out:

1. Set up a dial indicator as shown (**Figure 10-5**).
2. Manually rotate the rotor while observing indicated limits. Replace the turbocharger if run-out measurements are outside specified limits. *See table above.*

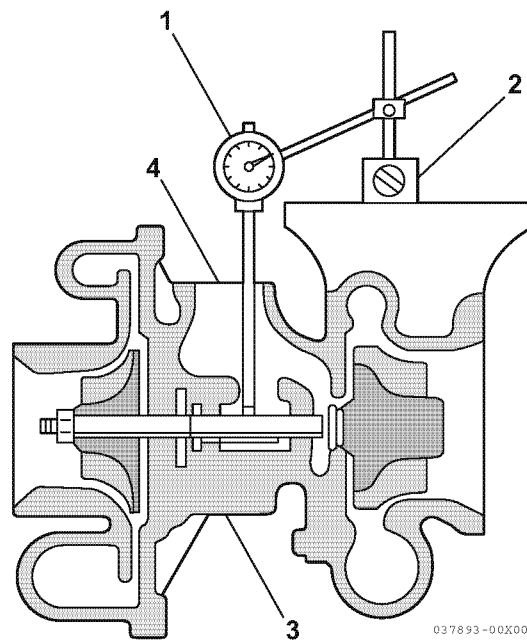

Figure 10-5

Waste Gate Valve Test

Before reinstalling the turbocharger, verify the operation of the waste gate valve. Poor waste gate operation will adversely affect the engine performance.

NOTICE

If the waste valve does not meet specifications, replace the turbocharger or have it repaired by a qualified repair facility.

1. Connect a hand-operated air pump to the waste gate actuator pipe (**Figure 10-6, (1)**). The pump should be equipped with a 30 PSI (0.21 MPa; 2.21 kgf/cm²) pressure gauge (**Figure 10-6, (2)**), and a pressure release valve to release any pressure pumped into the system. (Similar pumps are used to check for leaks in marine gear cases.)

⚠ WARNING

Never apply over 40 PSI (2.8 kgf/cm) to the waste gate actuator.

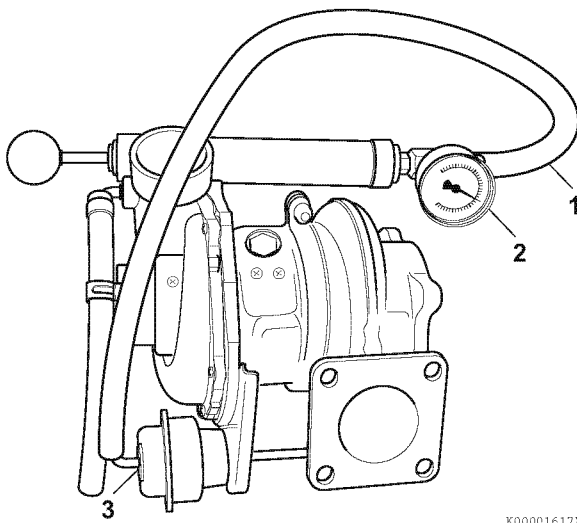

Figure 10-6

2. Apply 17 PSI (0.12 MPa; 1.2 kgf/cm²) to the waste gate actuator (**Figure 10-6, (3)**) circuit. Observe if the waste gate valve is open fully. If the waste valve does not open fully, replace the turbocharger or have it repaired by a qualified repair facility.

Waste Gate Actuator Leak Test

Allow the pressure, 17 PSI (0.12 MPa; 1.2 kgf/cm²) to remain in the circuit for one minute. After one minute, observe the pressure reading.

- If the pressure reading is equal to or greater than 15.9 PSI (0.11 MPa; 1.1 kgf/cm²), the waste gate actuator is not leaking and is operating properly.
- If the pressure reading is less than 15.9 PSI (0.11 MPa; 1.1 kgf/cm²), the waste gate actuator is leaking. Replace the turbocharger or have it repaired by a qualified repair facility.

Installation of Turbocharger

1. Pour 2 oz (60 cc) of clean engine oil in the oil inlet port at the top of the turbocharger. Rotate the compressor wheel to ensure the shaft bearings are lubricated.
2. Flush the oil lines to ensure that they are free of containments.
3. Put a new turbocharger exhaust manifold gasket in place and reinstall turbocharger on the exhaust manifold.
4. Apply anti-seize compound to the turbocharger mounting studs.
5. Reinstall the mounting nuts. Torque the nuts to the specified torque.
6. Install new sealing washers and O-rings and reinstall the inlet and outlet oil lines to the turbocharger.

NOTICE

Do not allow any material to fall into the oil lines or the oil inlet and outlet ports of the turbocharger.

7. Reinstall the air inlet connection to the turbocharger turbine housing.
8. Reinstall the exhaust connection to the turbocharger compressor housing.

This Page Intentionally Left Blank

Section 11

STARTER MOTOR

	Page
Before You Begin Servicing	11-3
Introduction.....	11-4
Starter Motor Information	11-4
3TNV88C to 4TNV86CT - Standard and Optional.....	11-4
4TNV98C and 4TNV98CT - Standard and Optional.....	11-4
Starter Motor Specifications	11-5
Starter Motor Troubleshooting.....	11-6
Starter Motor Components	11-7
Starter Motor	11-8
Removal of Starter Motor	11-8
Disassembly of Starter Motor	11-8
Cleaning and Inspection	11-10
Reassembly of Starter Motor.....	11-15
Check Pinion Projection Length	11-16
No-Load Test.....	11-17
Installation of Starter Motor	11-18

This Page Intentionally Left Blank

BEFORE YOU BEGIN SERVICING

Before performing any service procedures within this section, read the following safety information and review the *Safety* section on page 3-1.

INTRODUCTION

This section of the Service Manual covers the servicing of the starter motor. YANMAR Part No. 129900-77010 is typical equipment on 4TNV98C model engines and is used in this section to show the service procedures for a representative starter motor. For specific part detail, see the *YANMAR Parts Catalog* for the engine you are working on.

STARTER MOTOR INFORMATION

3TNV88C to 4TNV86CT - Standard and Optional

YANMAR Part No.	Mfg.	Mfg. Part No.	Specification	No load			Loaded			
				Terminal voltage	Amperage draw	min ⁻¹ (rpm)	Terminal voltage	Amperage draw	Torque	min ⁻¹ (rpm)
129129-77010	Denso	228000-0251	DC 12 V-1.6 HP (1.2 kW)	11.5	90 A maximum	3000	8	280 maximum	87 in.-lb (9.81 N·m; 1.0 kgf·m)	900
129407-77010	Denso	228000-3732	DC 12 V-1.9 HP (1.4 kW)	11.5	90 A maximum	3000	8.5	350 maximum	117 in.-lb (13.2 N·m; 1.4 kgf·m)	1000
129608-77010	Hitachi	S114-817A	DC 12 V-1.9 HP (1.4 kW)	11	90 A maximum	2700	8.4	250 maximum	74 in.-lb (8.3 N·m; 0.9 kgf·m)	1000
129242-77010	Hitachi	S114-883	DC 12 V-2.3 HP (1.7 kW)	11	90 A maximum	2300	8	370 maximum	134 in.-lb (15.1 N·m; 1.5 kgf·m)	880
129136-77011	Hitachi	S13-332	DC 12 V-3.1 HP (2.3 kW)	11	140 A maximum	4100	7.7	400 maximum	97 in.-lb (11.0 N·m; 1.1 kgf·m)	1400

4TNV98C and 4TNV98CT - Standard and Optional

YANMAR Part No.	Mfg.	Mfg. Part No.	Specification	No load			Loaded			
				Terminal voltage	Amperage draw	min ⁻¹ (rpm)	Terminal voltage	Amperage draw	Torque	min ⁻¹ (rpm)
129900-77010	Hitachi	S13-204	DC 12 V-3.1 hp (2.3 kW)	11	140 A maximum	4100	7.7	400 maximum	97 in.-lb (11.0 N·m; 1.1 kgf·m)	1400
129940-77011	Hitachi	S14-102	DC 12 V-4.0 hp (3.0 kW)	12	160 A maximum	3600	10.85	300 maximum	60 in.-lb (6.9 N·m; 0.7 kgf·m)	2000

STARTER MOTOR SPECIFICATIONS

YANMAR Part No.		129900-77010	
Nominal output		3.0 HP (2.3 kW)	
Weight		12.1 lb (5.5 kg)	
Revolution direction (as viewed from pinion)		Clockwise	
Engagement system		Magnetic shift	
No-load	Terminal voltage/current	11 V/140 A max	
	Revolution	4100 min ⁻¹ (rpm)	
Loaded	Terminal voltage/current	2.5 V/1050 A maximum	
	Torque	18 ft-lb (24.5 N·m; 2.5 kgf·m) minimum	
Clutch system		Overrunning	
Pinion projection voltage at 212 °F (100 °C)		8.6 V maximum	
Pinion DP or module/number of teeth		M3/9	
Difference (O-ring, oil seal)		Dry (none)	
Application		Standard	
Brush	Spring force	7.868 lbf (35 N; 3.6 kgf)	
	Height	Standard	0.591 in. (15 mm)
		Limit	0.354 in. (9 mm)
Magnetic switch	Series coil resistance	0.27 W at 68 °F (20 °C)	
	Shunt coil resistance	0.60 W at 68 °F (20 °C)	
Commutator	Outside diameter	Standard	1.437 in. (36.5 mm)
		Limit	1.398 in. (35 mm)
	Run-out	Standard	0.001 in. (0.03 mm)
		Limit	0.008 in. (0.2 mm)
	Insulation depth	Standard	0.020 - 0.031 in. (0.5 - 0.8 mm)
		Limit	0.008 in. (0.2 mm)
Armature	Run-out	Standard	0.001 in. (0.03 mm)
		Limit	0.008 in. (0.02 mm)
Bearing type	Armature front	Nominal No.	6903DDU
	Armature rear		608DDU
	Pinion front		60004DDU
	Pinion rear		6904DDU
Pinion projection length (length L)		0.012 - 0.059 in. (0.3 - 1.5 mm)	

STARTER MOTOR TROUBLESHOOTING

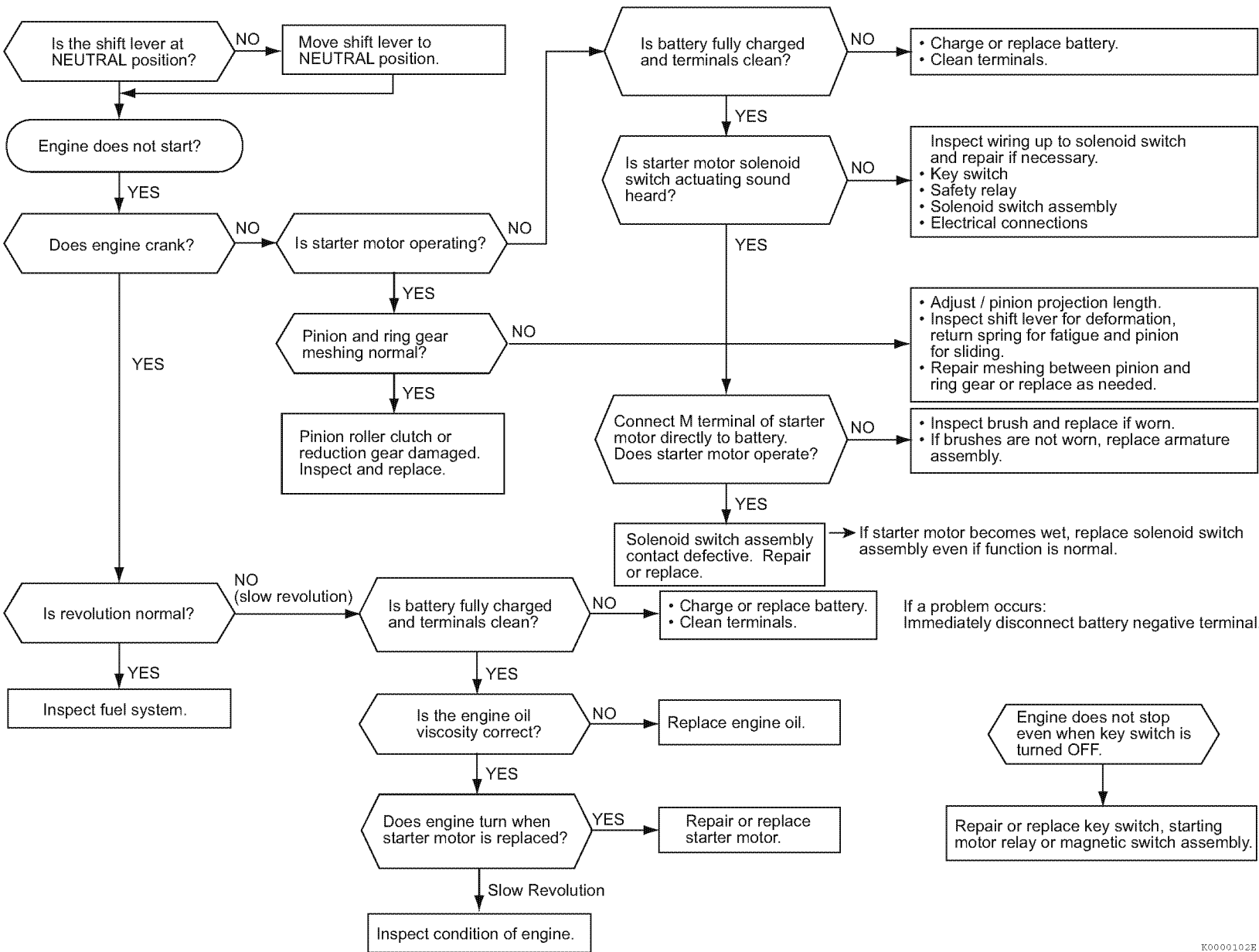

K0000102E

If a problem occurs: Immediately disconnect battery negative terminal.

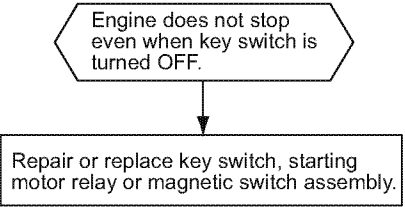

STARTER MOTOR COMPONENTS

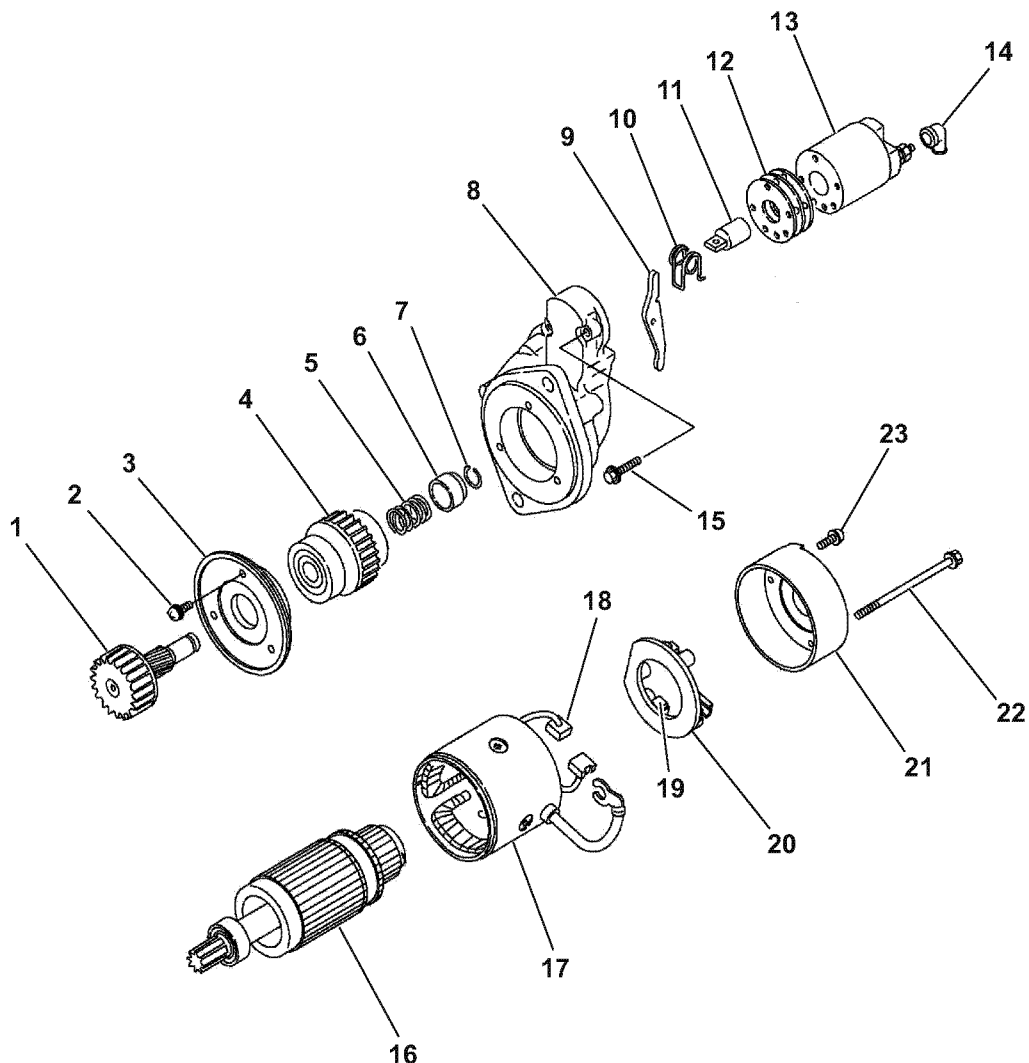

K0000102A

- | | |
|---|---|
| <ul style="list-style-type: none"> 1 – Pinion shaft 2 – M4 bolts (3 used) 3 – Bearing retainer 4 – Pinion clutch assembly 5 – Return spring 6 – Pinion stop 7 – Retaining ring 8 – Gear housing 9 – Shift lever 10 – Torsion spring 11 – Plunger 12 – Dust covers (shims) | <ul style="list-style-type: none"> 13 – Magnetic switch assembly (solenoid) 14 – Cover 15 – M6 bolts (2 used) 16 – Armature assembly 17 – Field coil assembly 18 – Positive (+) brushes 19 – Negative (-) brushes 20 – Brush holder assembly 21 – Rear cover 22 – M5 through bolts (2 used) 23 – M4 bolts (2 used) |
|---|---|

Figure 11-1

STARTER MOTOR

WARNING**Shock Hazard!**

- Turn off the battery switch (if equipped) or disconnect the negative battery cable before servicing the electrical system.

- Check the electrical harnesses for cracks, abrasions, and damaged or corroded connectors. Always keep the connectors and terminals clean.
- Failure to comply could result in death or serious injury.

Note: While starter motor design varies between models, the basic repair procedures are the same. The following procedures are typical and may differ from the stater being serviced.

Removal of Starter Motor

1. Disconnect the battery cables at the battery, negative (-) cable first.
2. Remove the electrical wires from the magnetic switch assembly.
3. Remove the starter mounting bolts (Figure 11-2, (1)). Remove the starter motor from the flywheel housing.

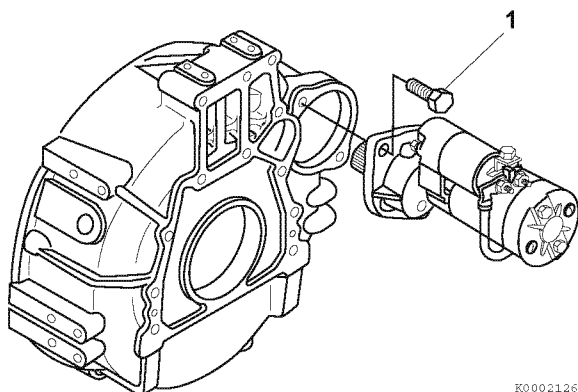

K0002126

Figure 11-2**Disassembly of Starter Motor**

1. Loosen the M8 nut from the magnetic switch (solenoid) assembly (Figure 11-3). Disconnect the wire from the magnetic switch.

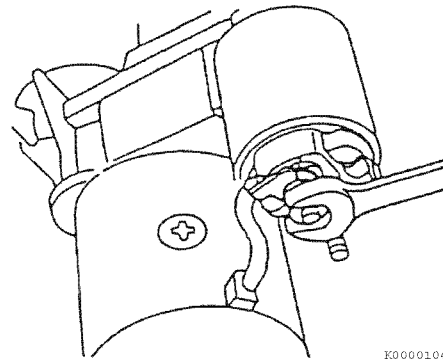

K0000104

Figure 11-3

2. Remove the two M4 bolts (Figure 11-4, (1)) securing the rear cover (Figure 11-4, (2)) to the brush holder assembly (Figure 11-4, (3)).

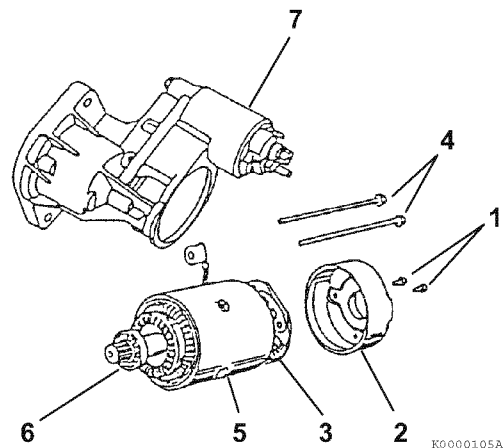

K0000105A

Figure 11-4

3. Remove the two M5 through bolts (Figure 11-4, (4)). Separate the rear cover (Figure 11-4, (2)), field coil assembly (Figure 11-4, (5)) with the armature assembly (Figure 11-4, (6)) from the gear housing (Figure 11-4, (7)).

4. Pull the brush springs up using a brush spring puller. On the negative (-) side, bring the brush spring into contact with the side of the brush for lifting from the commutator surface. On the positive (+) side, remove the brush from the brush holder assembly **(Figure 11-5, (1))**.

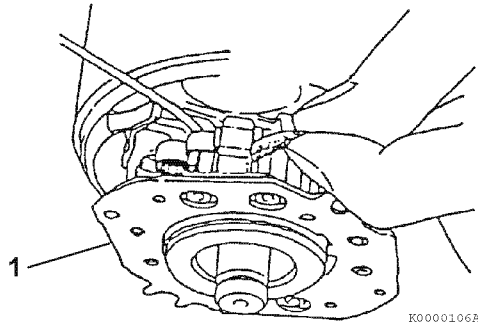

Figure 11-5

5. Remove the brush holder assembly **(Figure 11-6, (1))** from the armature assembly **(Figure 11-6, (3))**.

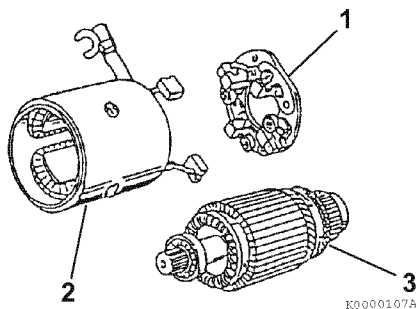

Figure 11-6

6. Pull the armature assembly **(Figure 11-6, (3))** out from the field coil assembly **(Figure 11-6, (2))**.
7. Remove the two M6 bolts **(Figure 11-7, (1))** retaining the magnetic switch assembly **(Figure 11-7, (2))** to the gear housing. Remove the magnetic switch assembly, dust cover(s) **(Figure 11-7, (3))** and torsion spring **(Figure 11-7, (4))** from the gear housing.

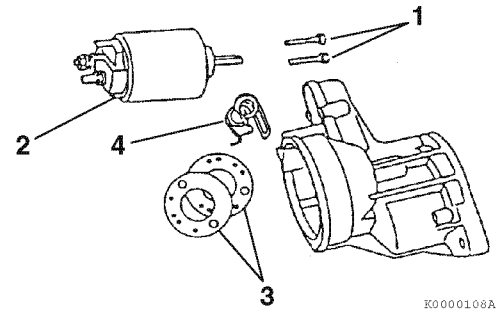

Figure 11-7

8. Disassemble the dust cover **(Figure 11-8, (3))** and shift the lever **(Figure 11-8, (4))** from the gear housing.

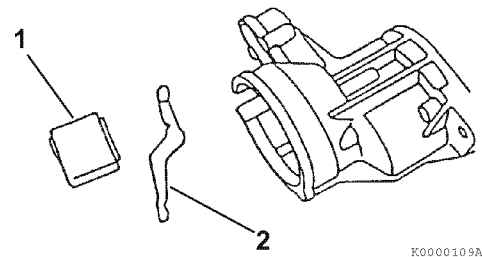

Figure 11-8

9. Remove the three M4 bolts **(Figure 11-9, (1))** securing the bearing retainer assembly **(Figure 11-9, (2))** to the gear housing. Remove the bearing retainer assembly from the gear housing.

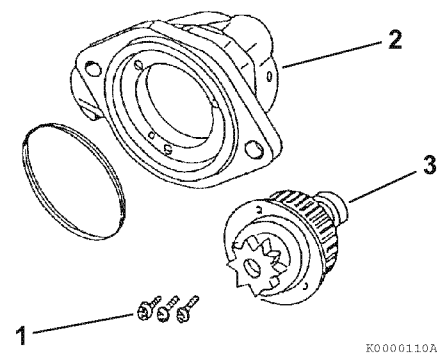

Figure 11-9

10. Remove the pinion clutch assembly (Figure 11-9, (3)) from the bearing retainer assembly.
11. Using a flat-blade screwdriver, remove the retaining ring (Figure 11-10, (1)) from the shaft of the pinion.

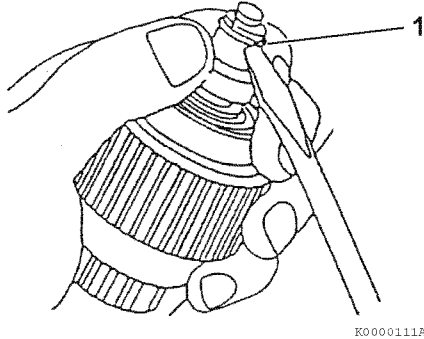

Figure 11-10

12. Disassemble the pinion stop (Figure 11-11, (3)), return spring (Figure 11-11, (4)), pinion clutch assembly (Figure 11-11, (1)), and pinion shaft (Figure 11-11, (5)).

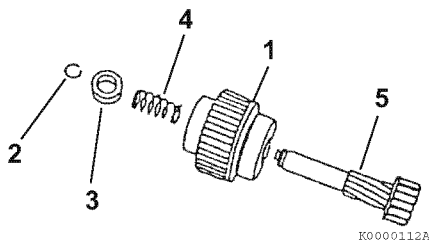

Figure 11-11

Cleaning and Inspection

■ **Armature**

Commutator surface inspection

If the commutator surface is rough, polish the surface with a #500 to #600 emery cloth (Figure 11-12).

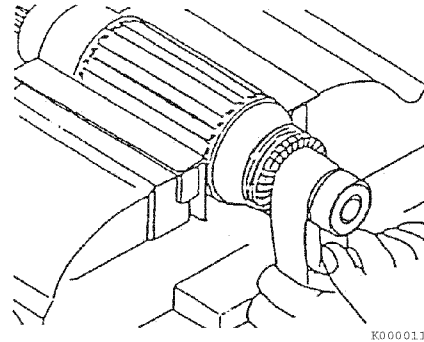

Figure 11-12

Measure commutator outside diameter

Measure the commutator outside diameter (Figure 11-13). Replace the armature if the measurement is less than the limit.

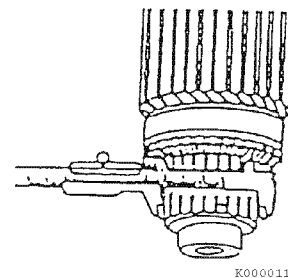

Figure 11-13

See Starter Motor Specifications on page 11-5 for the service limit.

Measure commutator insulation depth

Measure the depth of the insulating material (Figure 11-14, (1)) between commutator segments (Figure 11-14, (2)). If the depth measures less than the limit, use a hacksaw blade (Figure 11-14, (3)) to remove the insulating material until the depth is within the limit.

A normal commutator condition is indicated in (Figure 11-14, (4)). An abnormal commutator condition is indicated in (Figure 11-14, (5)).

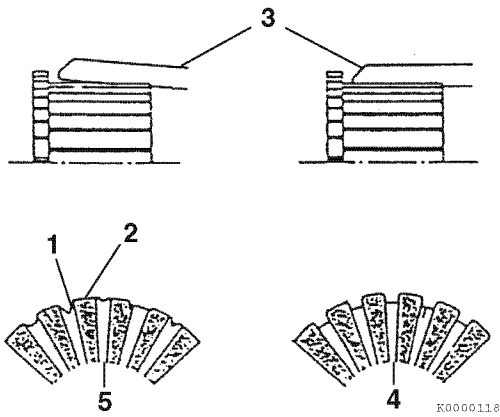

Figure 11-14

See Starter Motor Specifications on page 11-5 for the service limit.

Armature coil continuity test

Check for continuity between the commutator segments using a multimeter (Figure 11-15). The multimeter should indicate continuity.

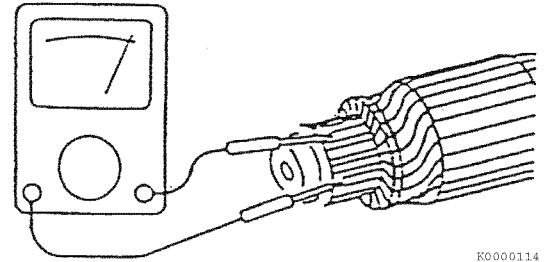

Figure 11-15

If the multimeter does not indicate continuity, replace the armature.

Armature coil insulation test

Check for continuity between a commutator segment and the shaft or armature using a multimeter (Figure 11-16). The multimeter should not indicate continuity.

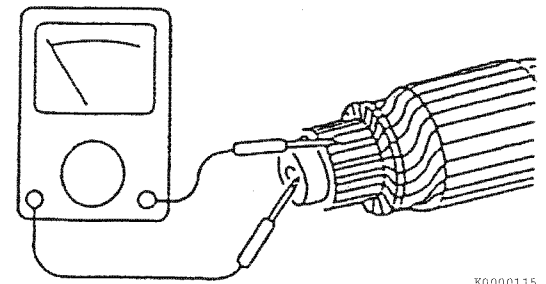

Figure 11-16

If the multimeter indicates continuity, replace the armature.

Measure armature and commutator run-outs

Measure the armature core run-out and the commutator run-out using a dial indicator (Figure 11-17). Replace the armature if either of the measurements is less than the limit.

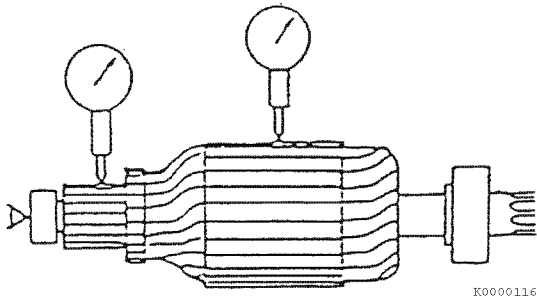

Figure 11-17

See Starter Motor Specifications on page 11-5 for the service limit.

■ **Field coil**

Field coil continuity test

Check for continuity between the field coil terminals using a multimeter (Figure 11-18). The multimeter should indicate continuity.

If the multimeter does not indicate continuity, replace the field coil assembly.

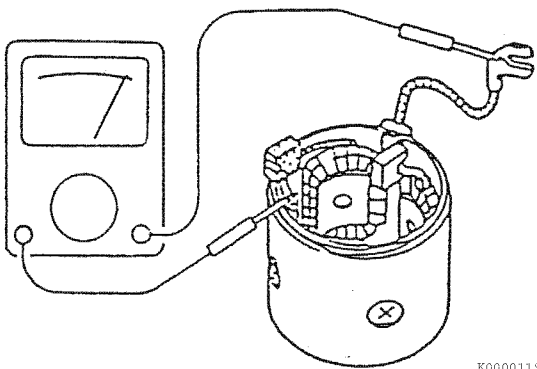

Figure 11-18

Field coil insulation test

Check for continuity between the field coil terminal and the yoke using a multimeter (Figure 11-19). The multimeter should not indicate continuity.

If the multimeter indicates continuity, replace the field coil assembly.

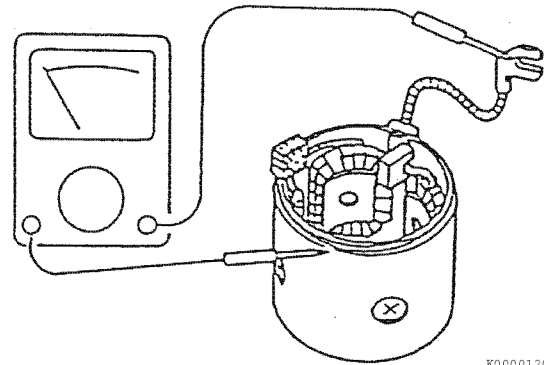

Figure 11-19

Measure brush length

Measure the length of the brush (Figure 11-20). Replace the brush if the length is less than the limit.

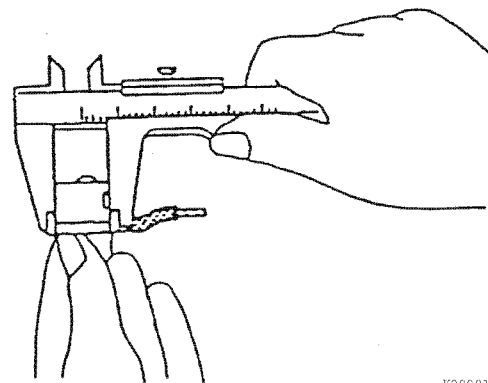

Figure 11-20

See Starter Motor Specifications on page 11-5 for the service limit.

■ **Magnetic switch**

If the starter motor becomes wet, replace the magnetic switch even if the magnetic switch assembly function is normal.

Shunt coil continuity test

Check for continuity between the “S” terminal and the switch body using a multimeter (**Figure 11-21**). The multimeter should indicate continuity.

If the multimeter does not indicate continuity, replace the magnetic switch.

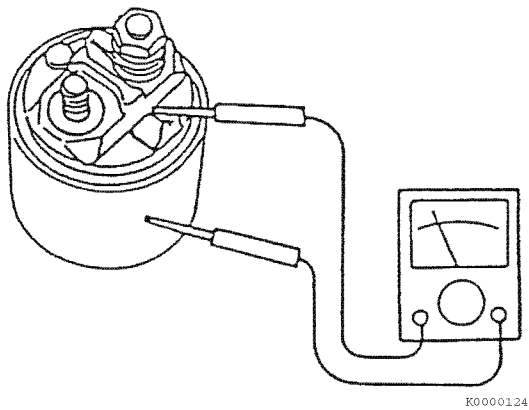

Figure 11-21

Series coil continuity test

Check for continuity between the “S” and “M” terminals using a multimeter (**Figure 11-22**). The multimeter should indicate continuity.

If the multimeter does not indicate continuity, replace the magnetic switch.

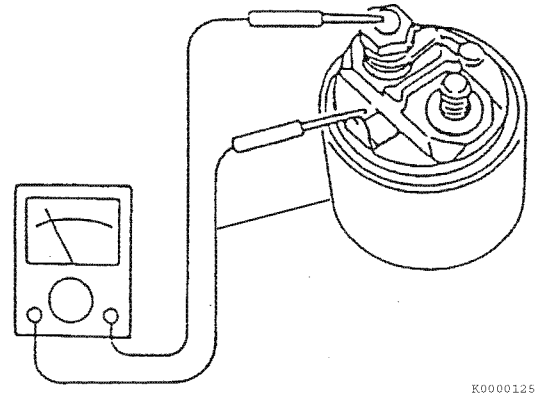

Figure 11-22

Coil resistance test

See Starter Motor Specifications on page 11-5 for the service limit.

Contact continuity test

Depress the plunger at the bottom of the magnetic switch. Check for continuity between the “B” and “M” terminals using a multimeter (**Figure 11-23**). The multimeter should indicate continuity.

If the multimeter does not indicate continuity, replace the magnetic switch.

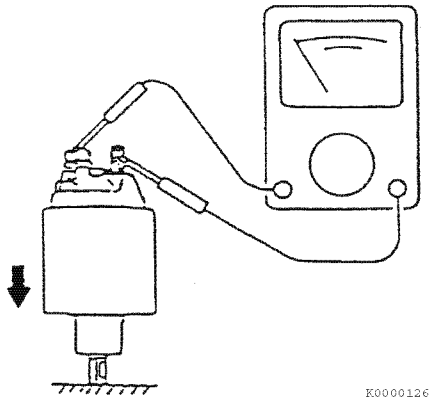

Figure 11-23

■ **Pinion clutch assembly**

Pinion clutch assembly inspection

Manually rotate the pinion clutch assembly in the drive direction (**Figure 11-24**). It should rotate freely in the drive direction and is locked by turning it in the opposite direction. Replace the pinion clutch assembly if the results are different.

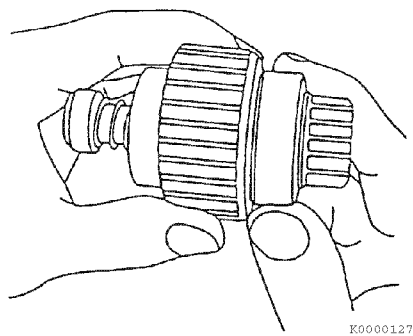

Figure 11-24

Slide the pinion clutch assembly on the shaft. It should slide smoothly on the shaft (**Figure 11-25**). Rust, too much grease or damage could prevent the pinion clutch from sliding smoothly. If the pinion clutch assembly does not slide smoothly, clean the shaft and pinion clutch assembly or replace the damaged component.

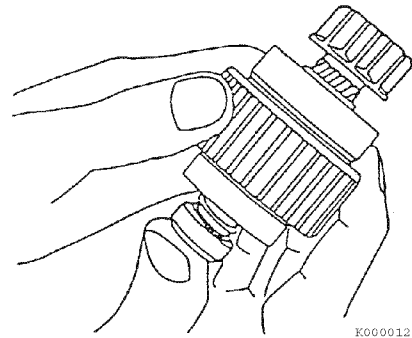

Figure 11-25

Ball bearing inspection

Rotate each ball bearing while holding the pinion clutch assembly (**Figure 11-26**). Replace the ball bearing if it does not rotate smoothly or has excessive play.

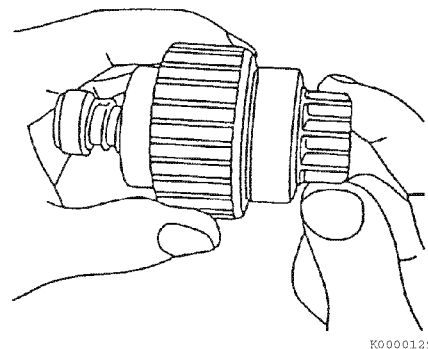

Figure 11-26

Reassembly of Starter Motor

1. Apply the appropriate starter bendix grease (obtain locally) to the pinion shaft. Reassemble the pinion shaft (**Figure 11-27, (5)**), pinion clutch assembly (**Figure 11-27, (1)**), return spring (**Figure 11-27, (4)**) and pinion stop (**Figure 11-27, (3)**). Reinstall the retaining ring (**Figure 11-27, (2)**) in the groove in the pinion shaft. Slide the piston stop over the retaining ring.

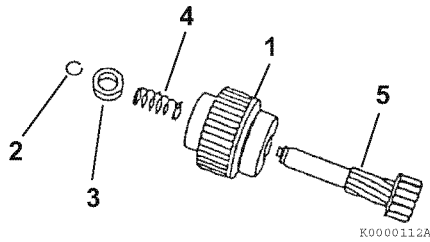

Figure 11-27

2. Reinstall the pinion clutch assembly into the bearing retainer assembly.
3. Reinstall the bearing retainer assembly and pinion assembly to the gear housing. Reinstall and tighten the three M4 bolts.
4. Apply a small amount of high temperature lithium grease (obtain locally) to the sliding portions of the shift lever (**Figure 11-28, (1)**). Reassemble the torsion spring (**Figure 11-28, (2)**), shift lever and dust cover(s) (**Figure 11-28, (3)**), plunger (**Figure 11-28, (4)**) and magnetic switch assembly (**Figure 11-28, (5)**).

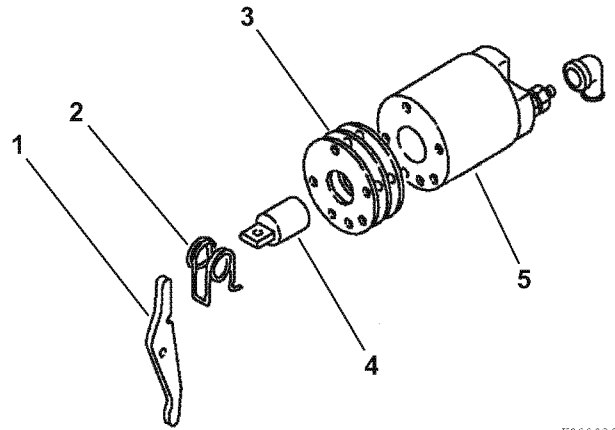

Figure 11-28

5. Reassemble the magnetic switch assembly to the gear housing. Pry the pinion away from the gear housing to allow installation of the magnetic switch assembly (**Figure 11-29**).

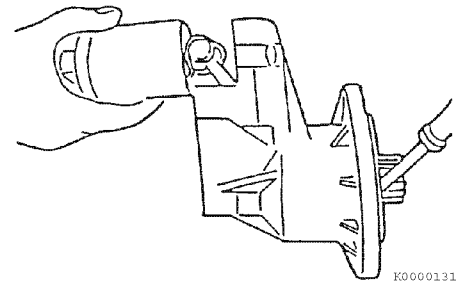

Figure 11-29

6. Secure the magnetic switch assembly to the gear housing using the two M6 bolts.

- Carefully install the armature assembly (**Figure 11-30, (1)**) into the field coil assembly (**Figure 11-30, (2)**).

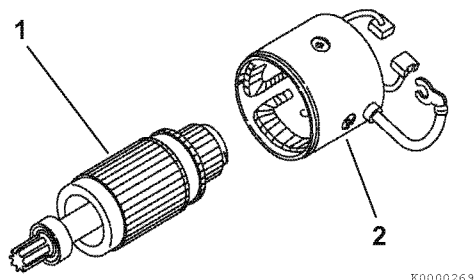

Figure 11-30

- Position the brush springs in brush holders (**Figure 11-31**). Reinstall the brushes in the brush holders. Reversing the brushes will cause the starter motor to turn backwards.

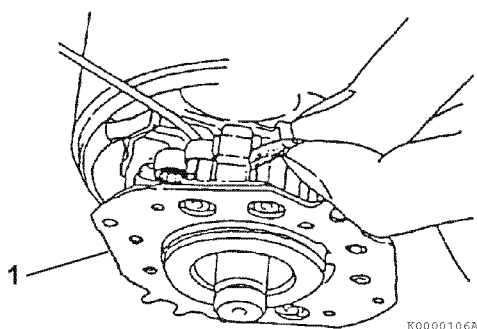

Figure 11-31

- Carefully install the brush holder assembly to the armature assembly.
- Reinstall the field coil assembly with the armature assembly to the gear housing.
- Reinstall the rear cover to the brush holder assembly. Securely tighten the two bolts.

- Reinstall the two M4 through bolts (**Figure 11-32**). Securely tighten the through bolts. Reconnect the wire to the magnetic switch assembly. Tighten the M8 nut. Reinstall the cover over the connection.

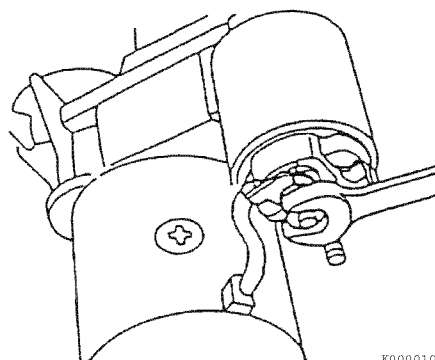

Figure 11-32

Check Pinion Projection Length

- Connect the positive (+) lead from a battery to the "S" terminal.
- Connect the negative (-) lead to the "M" terminal.
- Lightly pull the pinion away from the gear housing.
- Turn the switch ON and measure the pinion moving distance L in the thrust direction (**Figure 11-33**). Perform this test within 10 seconds. See *Starter Motor Specifications* on page 11-5 for the service limit.

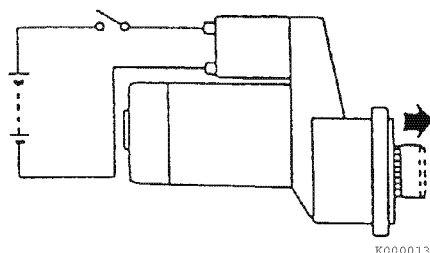

Figure 11-33

- If the measured L dimension is outside the standard range, adjust the dust covers to obtain the standard range. Dust covers (Figure 11-34, (1)) are available in 0.020 in. (0.5 mm) and 0.031 in. (0.8 mm) thicknesses.

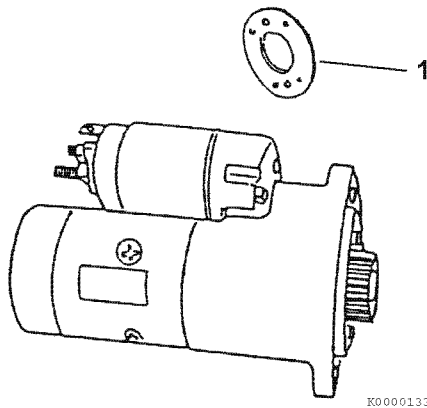

Figure 11-34

No-Load Test

Test the characteristics of the starter motor by performing a no-load test.

NOTICE

The starter motor can be damaged if operated continuously longer than 10 seconds while performing the no-load test.

- Secure the starting motor in a vise or other suitable fixture.
- Connect an ammeter (Figure 11-35, (1)) in series between the battery positive (+) terminal (Figure 11-35, (2)) and the main positive (+) terminal (Figure 11-35, (3)) on the starter motor.

Note: The ammeter and all wire leads used in this test must have a capacity equal to or greater than the amperage draw specification for the starter motor being tested.

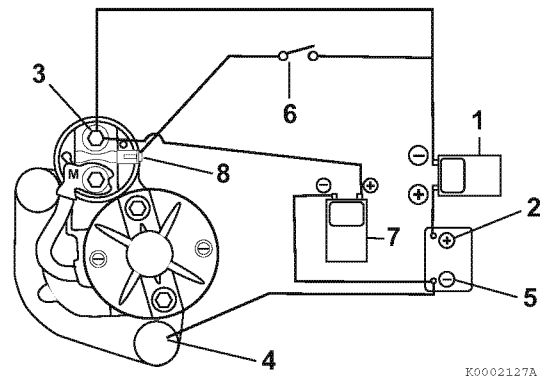

Figure 11-35

- Connect a wire lead between the mounting base of the starter motor (Figure 11-35, (4)) and the battery negative terminal (Figure 11-35, (5)).
- Connect a voltmeter (Figure 11-35, (7)) to the battery negative (-) terminal (Figure 11-35, (5)) and the main positive (+) battery terminal (Figure 11-35, (3)) on the starter motor.
- Install a switch (Figure 11-35, (6)) in a circuit between the battery positive (+) terminal (Figure 11-35, (2)) and the starter magnetic switch (solenoid) terminal (Figure 11-35, (8)) on the starter motor.
- Use a suitable tachometer to monitor the rpm of the starter.
- Turn the switch to the ON position. Monitor the rpm, amperage draw and voltage. For test specifications, see 3TNV88C to 4TNV86CT - Standard and Optional and 4TNV98C and 4TNV98CT - Standard and Optional on page 11-4 for the appropriate starter motor.

Installation of Starter Motor

1. Reinstall the starter motor to the flywheel housing.
2. Reinstall the starter mounting bolts (**Figure 11-36, (1)**). Tighten the bolts to specification. *See Tightening Torques for Standard Bolts and Nuts on page 4-39.*

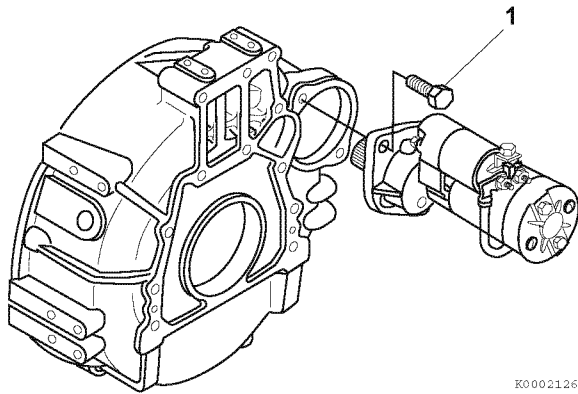

Figure 11-36

3. Reconnect the electrical wires to the magnetic switch assembly (solenoid). Be sure to place the cover over the battery positive (+) cable connection.
4. Reconnect the battery cables at the battery.

Section 12

ALTERNATOR

	Page
Before You Begin Servicing	12-3
Introduction.....	12-4
Dynamo and Alternator Information	12-4
3TNV88C to 4TNV98CT - Standard and Optional Dynamos	12-4
3TNV88C to 4TNV98CT - Standard and Optional Alternators	12-4
Alternator Specifications.....	12-5
Dynamo Specifications.....	12-5
Alternator Troubleshooting	12-6
Alternator Components	12-7
Alternator Wiring Diagram	12-8
Alternator Standard Output	12-9
Alternator	12-10
Removal of Alternator.....	12-10
Disassembly of Alternator.....	12-10
Reassembly of Alternator	12-12
Installation of Alternator.....	12-14
Dynamo Component Location.....	12-15
Dynamo Wiring Diagram	12-16
Operation of Dynamo	12-16
Dynamo Standard Output	12-17
Testing of Dynamo	12-18
Testing Stator Coil Continuity	12-18
Testing Stator Coil Short-to-Ground.....	12-18
Testing Dynamo Regulated Output	12-18
Dynamo	12-18
Removal of Dynamo	12-18

ALTERNATOR

Disassembly of Dynamo.....	12-19
Reassembly of Dynamo	12-19
Installation of Dynamo.....	12-20

BEFORE YOU BEGIN SERVICING

Before performing any service procedures within this section, read the following safety information and review the *Safety* section on page 3-1.

INTRODUCTION

This section of the Service Manual describes the servicing of the dynamos and alternators. YANMAR Part No. 129423-77200 alternator is used in this section to show the service procedures for the representative alternator. YANMAR Part No. 171301-77201 dynamo is used in this section to show the service procedures for the representative dynamo. For specific part detail, see the *Parts Catalog* for the engine you are working on.

DYNAMO AND ALTERNATOR INFORMATION

3TNV88C to 4TNV98CT - Standard and Optional Dynamos

YANMAR Part No.	Mfg.	Mfg. Part No.	Specification
171301-77201	Kokusan	GP8138	DC 12 V - 15 A
119910-77200	Kokusan	GP9191	DC 12 V - 20 A

3TNV88C to 4TNV98CT - Standard and Optional Alternators

YANMAR Part No.	Mfg.	Mfg. Part No.	Specification
119620-77201	Denso	100211-4531	DC 12 V - 40 A
129423-77200	Denso	101211-1170	DC 12 V - 40 A with pulse
129961-77200	Denso	101211-2591	DC 12 V - 55 A
119626-77210	Denso	101211-2951	DC 12 V - 55 A with pulse

ALTERNATOR SPECIFICATIONS

YANMAR Part No.	129423-77200
Nominal output (13.5 volts heat)	40 A
Weight	6.17 lb (2.8 kg)
Revolution direction (as viewed from pulley)	Clockwise
Rating	Continuous
Battery voltage	12 V
Rated revolution	5000 min ⁻¹ (rpm)
Operating range	1350 - 18000 min ⁻¹ (rpm)
Grounding characteristics	Negative (-) side of circuit
Integrated regulator	IC regulator
Outside diameter of pulley	2.724 in. (69.2 mm)
Belt shape	Type A

DYNAMO SPECIFICATIONS

YANMAR Part No.	119910-77200	
Nominal output	20 A	
Weight	3.97 lb (1.8 kg)	
Revolution direction (as viewed from pulley)	Clockwise	
Rating	Continuous	
Battery voltage	12 V	
Rated revolution	3500 min ⁻¹ (rpm)	
Operating range	1400 - 6600 min ⁻¹ (rpm)	
Grounding characteristics	Negative (-) side of circuit	
Regulator	Current limiter (YANMAR Part No. 119653-77710)	
Outside diameter of pulley	A-belt	2.56 in. (65 mm)
	Special M-belt	2.28 in. (58 mm)
Belt shape	Type A or type special M	

ALTERNATOR TROUBLESHOOTING

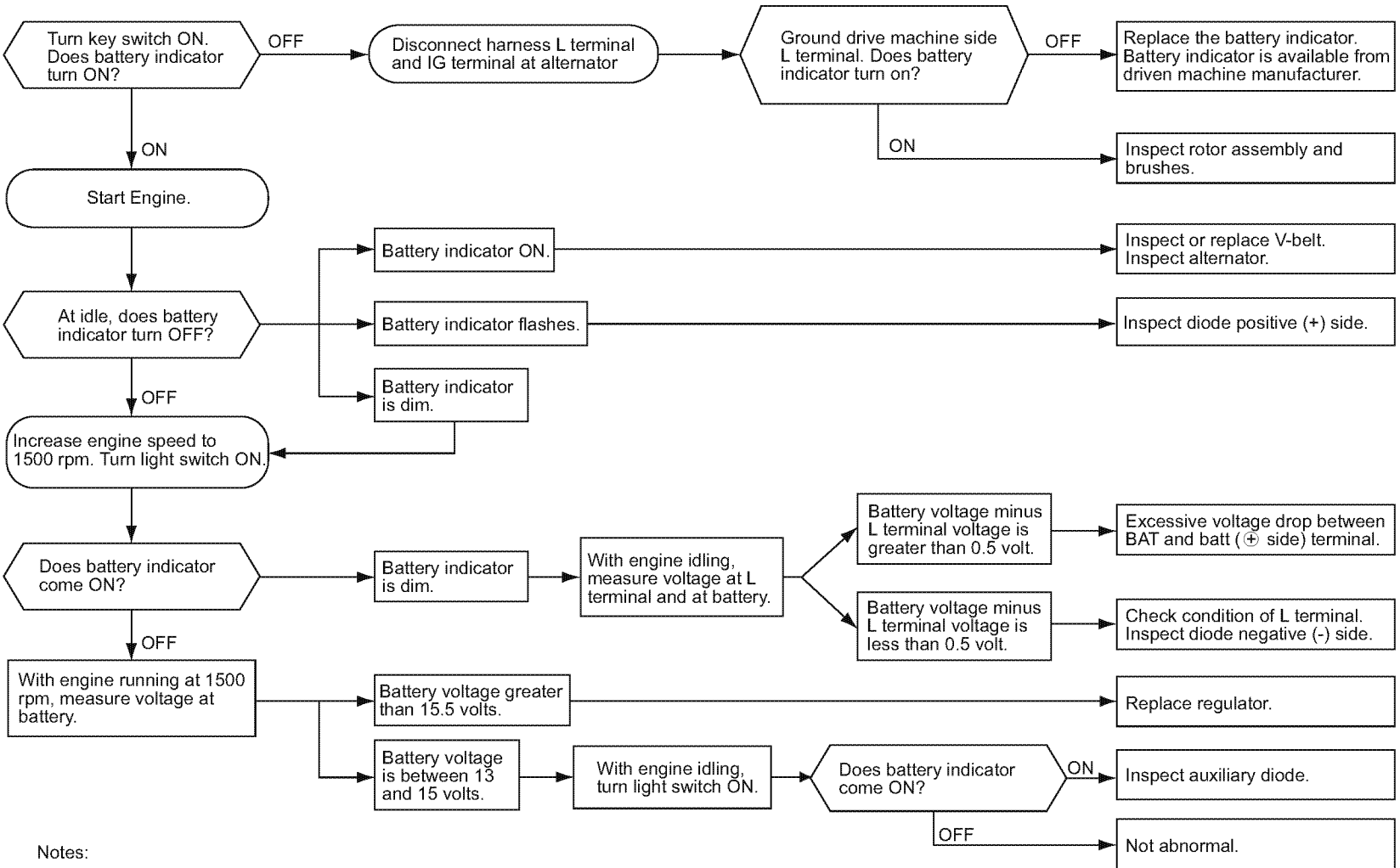

Notes:

1. Use a fully charged battery
2. DC voltmeter: 0 to 30 V, 0.5 class
3. The check method is also applicable to the bench test

ALTERNATOR COMPONENTS

YANMAR Part No. 129423-77200 alternator is used in this section to show the service procedures for the representative alternator. For specific part detail, see the *Parts Catalog* for the engine you are working on.

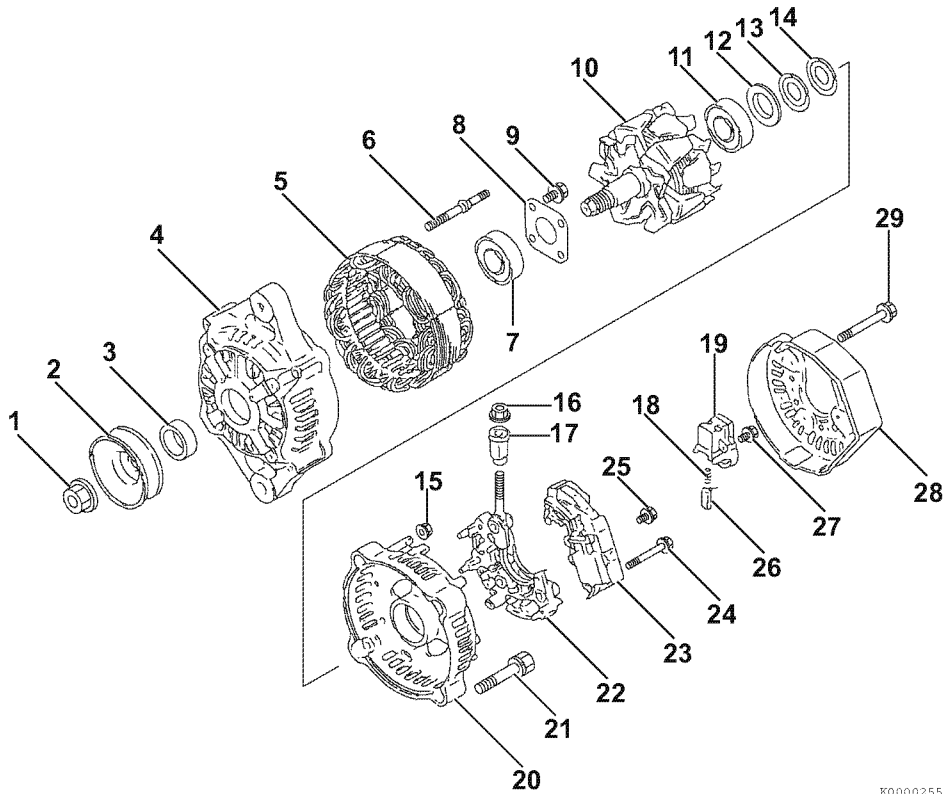

- | | |
|---------------------------------|----------------------------|
| 1 – Nut | 16 – Nut |
| 2 – Pulley | 17 – Insulation bushing |
| 3 – Collar | 18 – Spring (2 used) |
| 4 – Front frame housing | 19 – Brush holder |
| 5 – Stator assembly | 20 – Rear frame housing |
| 6 – Stud (2 used) | 21 – Bolt (2 used) |
| 7 – Front frame housing bearing | 22 – Holder |
| 8 – Bearing cover | 23 – IC regulator assembly |
| 9 – Bearing cover bolt (4 used) | 24 – Bolt (2 used) |
| 10 – Rotor assembly | 25 – Bolt |
| 11 – Rear frame housing bearing | 26 – Brush (2 used) |
| 12 – Bearing cover | 27 – Bolt |
| 13 – Thrust washer | 28 – Rear cover |
| 14 – Thrust washer | 29 – Bolt (3 used) |
| 15 – Nut (2 used) | |

Figure 12-1

ALTERNATOR WIRING DIAGRAM

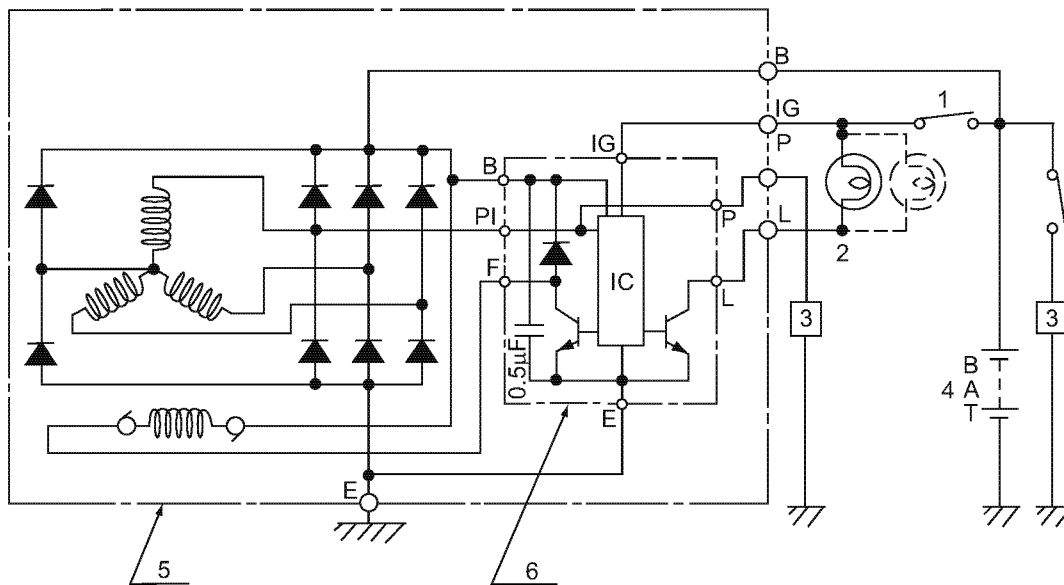

- 1 – Key switch
- 2 – Charge lamp (3.4 watts maximum)
- 3 – Load

- 4 – Battery
- 5 – Alternator assembly
- 6 – IC regulator assembly

Figure 12-2

NOTICE

Do not short-circuit the charging system between alternator terminals IG and L. Damage to the alternator will result.

NOTICE

Do not remove the positive (+) battery cable from alternator terminal B while the engine is operating. Damage to the alternator will result.

NOTICE

Do not connect a load between alternator terminals L and E. Damage to the alternator will result.

ALTERNATOR STANDARD OUTPUT

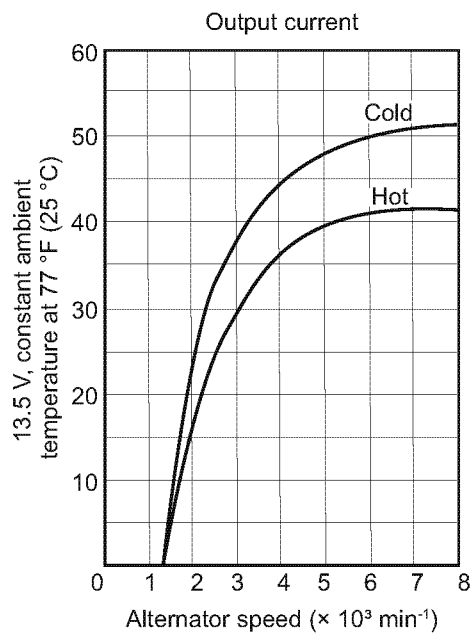

Figure 12-3

ALTERNATOR

⚠ WARNING**Shock Hazard!**

- Turn off the battery switch (if equipped) or disconnect the negative battery cable before servicing the electrical system.

- Check the electrical harnesses for cracks, abrasions, and damaged or corroded connectors. Always keep the connectors and terminals clean.
- Failure to comply could result in death or serious injury.

Removal of Alternator

⚠ CAUTION**Pinch Hazard!**

Carefully rotate the alternator toward the cylinder block while loosening the V-belt. Failure to comply may result in minor or moderate injury.

1. Disconnect the electrical wires from the alternator.
2. Loosen the V-belt.
3. Remove the V-belt adjuster from the alternator bolt (Figure 12-4, (1)).

4. Remove the nut (Figure 12-4, (2)) from the gear case stud. Remove the alternator.

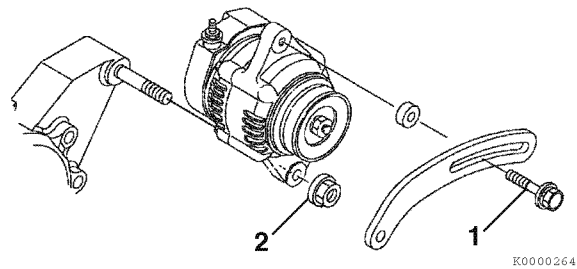

Figure 12-4

Disassembly of Alternator

1. Remove the nut (Figure 12-5, (1)) from the shaft of the rotor assembly. Remove the pulley (Figure 12-5, (2)).

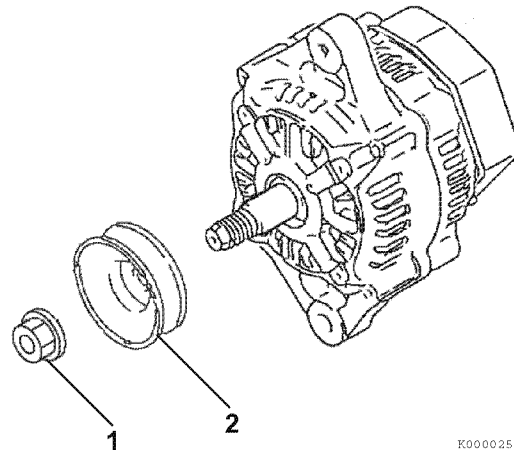

Figure 12-5

- Remove the three bolts (Figure 12-6, (1)) retaining the rear cover (Figure 12-6, (2)) to the rear frame assembly.

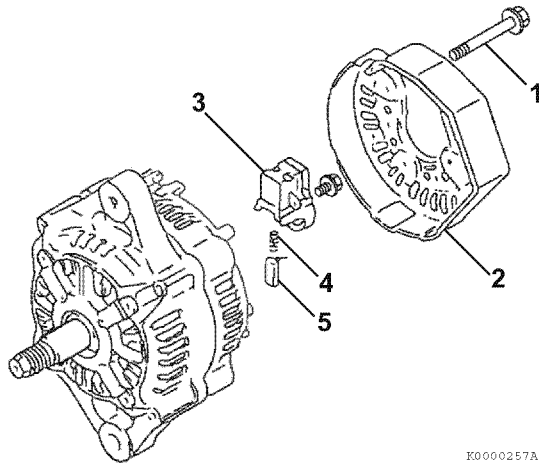

Figure 12-6

- Remove the brush holder (Figure 12-6, (3)). Remove the brush springs (Figure 12-6, (4)) and brushes (Figure 12-6, (5)).
- Remove the bolt retaining the regulator assembly (Figure 12-7, (1)) to the holder (Figure 12-7, (2)).

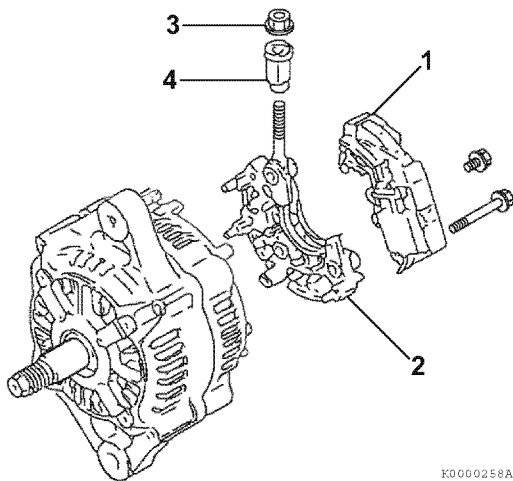

Figure 12-7

- Remove the bolts retaining the holder (Figure 12-7, (2)) to the rear frame housing. Remove the holder.

- Remove the nut (Figure 12-7, (3)) retaining the insulation bushing (Figure 12-7, (4)). Remove the insulation bushing.
- Remove the two bolts (Figure 12-8, (1)) and two nuts (Figure 12-8, (2)) securing the rear frame housing to the front frame housing.

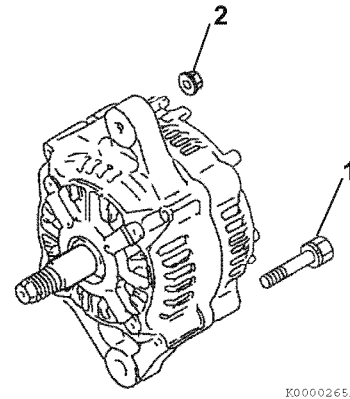

Figure 12-8

- Using a press, remove the rotor assembly (Figure 12-9, (1)) from the front frame housing (Figure 12-9, (2)) and rear frame housing (Figure 12-9, (3)).

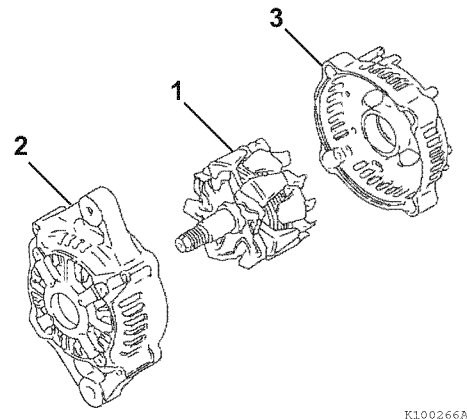
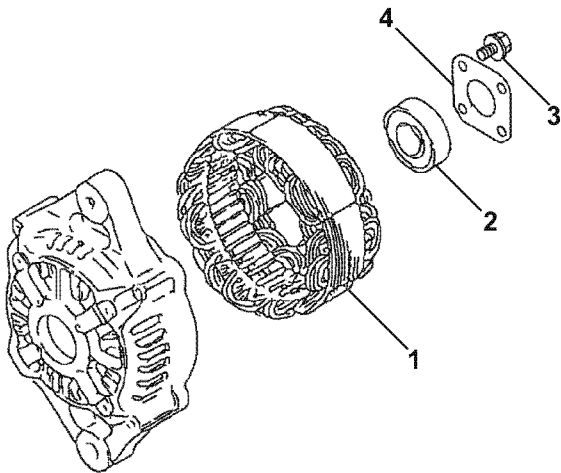

Figure 12-9

9. Remove the stator assembly (Figure 12-10, (1)) from the front frame housing.



K0000259A

Figure 12-10

10. If it is necessary to replace the bearing (Figure 12-10, (2)) in the front frame housing, remove the four bolts (Figure 12-10, (3)) securing the plate (Figure 12-10, (4)) to the front frame housing. Remove the plate. Use a puller to remove the bearing. Discard the bearing.
11. If it is necessary to replace the bearing (Figure 12-11, (1)) in the rear frame housing, use a puller to remove. Discard the bearing. Remove the bearing cover (Figure 12-11, (2)) and two thrust washers (Figure 12-11, (3)).

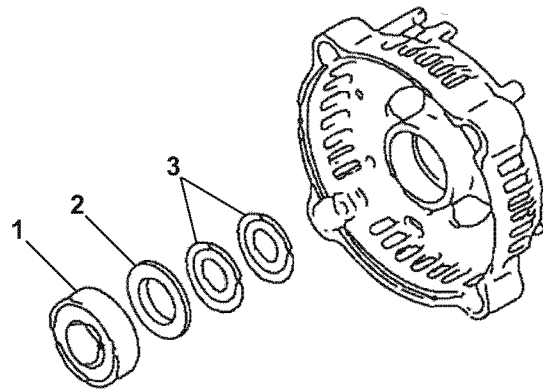

K0000260A

Figure 12-11

Reassembly of Alternator

1. If removed, reinstall the two thrust washers (Figure 12-12, (3)) and bearing cover (Figure 12-12, (2)) in the rear frame housing. Lubricate the outside diameter of a new bearing (Figure 12-12, (1)). Press the bearing into the rear frame housing.

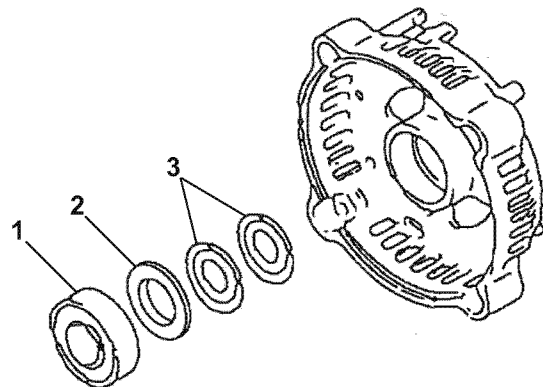

K0000260A

Figure 12-12

- If removed, lubricate the outside diameter of a new front frame housing bearing. Press the bearing (**Figure 12-13, (2)**) into the front frame housing. Reinstall the plate (**Figure 12-13, (4)**) to the front housing. Tighten the four bolts (**Figure 12-13, (3)**).

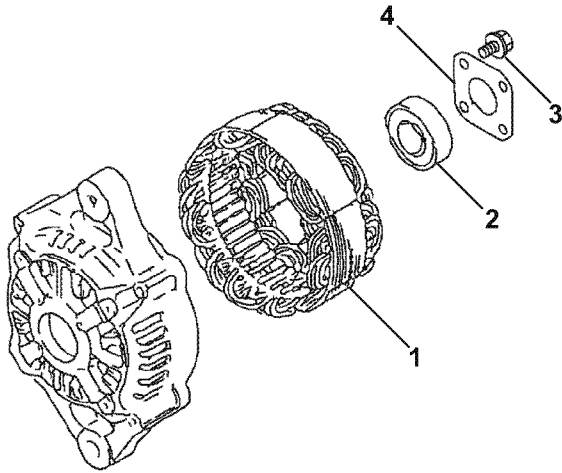

K0000259A

Figure 12-13

- Position the stator assembly (**Figure 12-13, (1)**) on the front frame housing studs.
- Lubricate the shaft of the rotor assembly (**Figure 12-14, (1)**). Press the rotor assembly into the front frame housing (**Figure 12-14, (2)**) and rear frame housing (**Figure 12-14, (3)**).

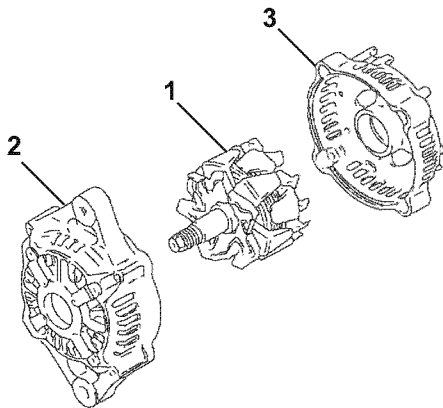

K100266A

Figure 12-14

- Align the front frame housing with the rear frame housing. Reinstall the two bolts (**Figure 12-15, (1)**) and two nuts (**Figure 12-15, (2)**).

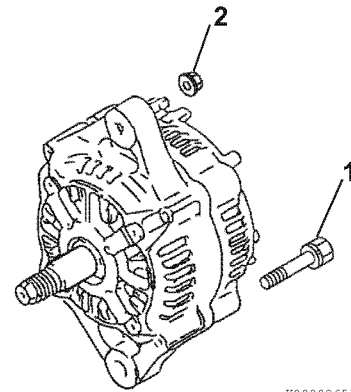

K0000265A

Figure 12-15

- Reinstall the insulation bushing (**Figure 12-16, (4)**) and nut (**Figure 12-16, (3)**).

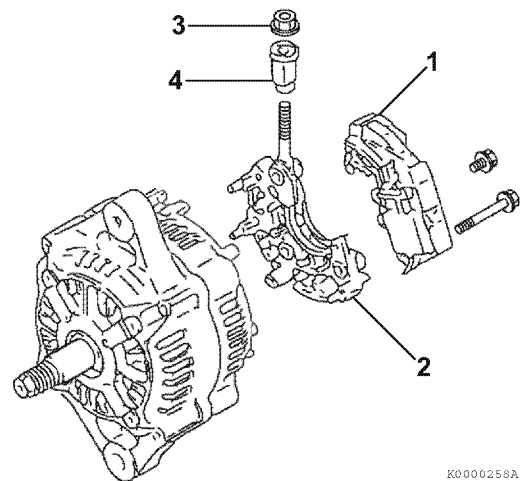

K0000256A

Figure 12-16

- Reassemble the regulator assembly (**Figure 12-16, (1)**) to the holder (**Figure 12-16, (2)**).

8. Reinstall the brush holder (**Figure 12-17, (3)**), springs (**Figure 12-17, (4)**) and brushes (**Figure 12-17, (5)**).
9. Reattach the regulator assembly and holder to the rear frame housing.

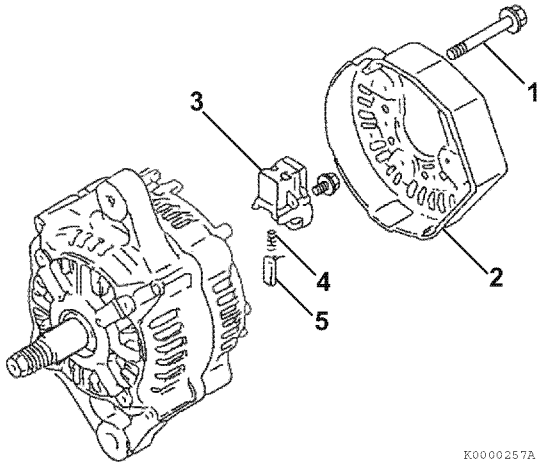

Figure 12-17

10. Reinstall the rear cover (**Figure 12-17, (2)**) to the rear frame housing with three bolts (**Figure 12-17, (1)**).
11. Reassemble the pulley (**Figure 12-18, (2)**) and nut (**Figure 12-18, (1)**) to the shaft of the rotor assembly. Tighten the nut.

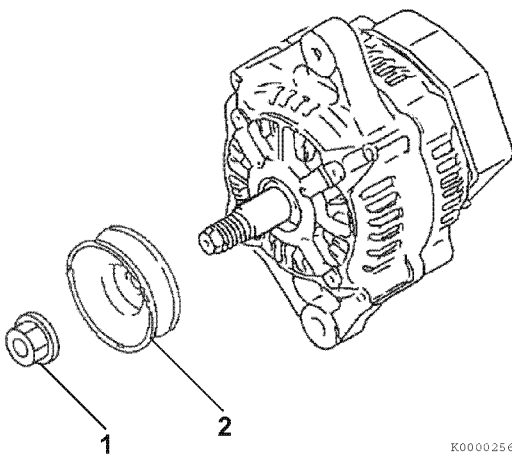

Figure 12-18

Installation of Alternator

1. Position the alternator on the gear case. Loosely reinstall the nut (**Figure 12-19, (2)**) on the gear case stud and the V-belt adjuster bolt (**Figure 12-19, (1)**).

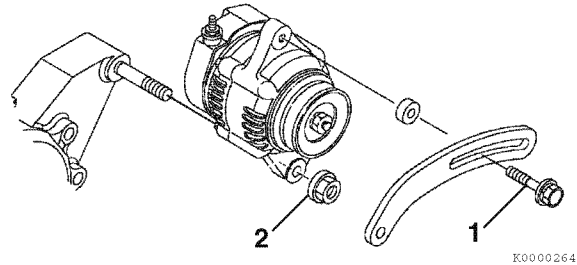

Figure 12-19

2. Reconnect the electrical wires to the alternator. Tighten the nuts to 15 - 20 in.-lb (1.7 - 2.3 N·m; 17 - 23 kgf·m).
3. Reinstall the V-belt. Tighten the V-belt to the proper tension as described in *Check and adjust cooling fan V-belt on page 5-9*.
4. Start the engine. Listen for any unusual sounds from the alternator.

NOTICE

Do not operate the engine if the alternator is producing unusual sounds. Damage to the alternator will result.

5. Verify that the charge indicator is ON while the engine is operating. If the charge indicator is not ON, repair the problem before operating the engine.

DYNAMO COMPONENT LOCATION

YANMAR Part No. 171301-77201 dynamo is used in this section to show the service procedures for the representative dynamo. For specific part detail, see the *Parts Catalog* for the engine you are working on.

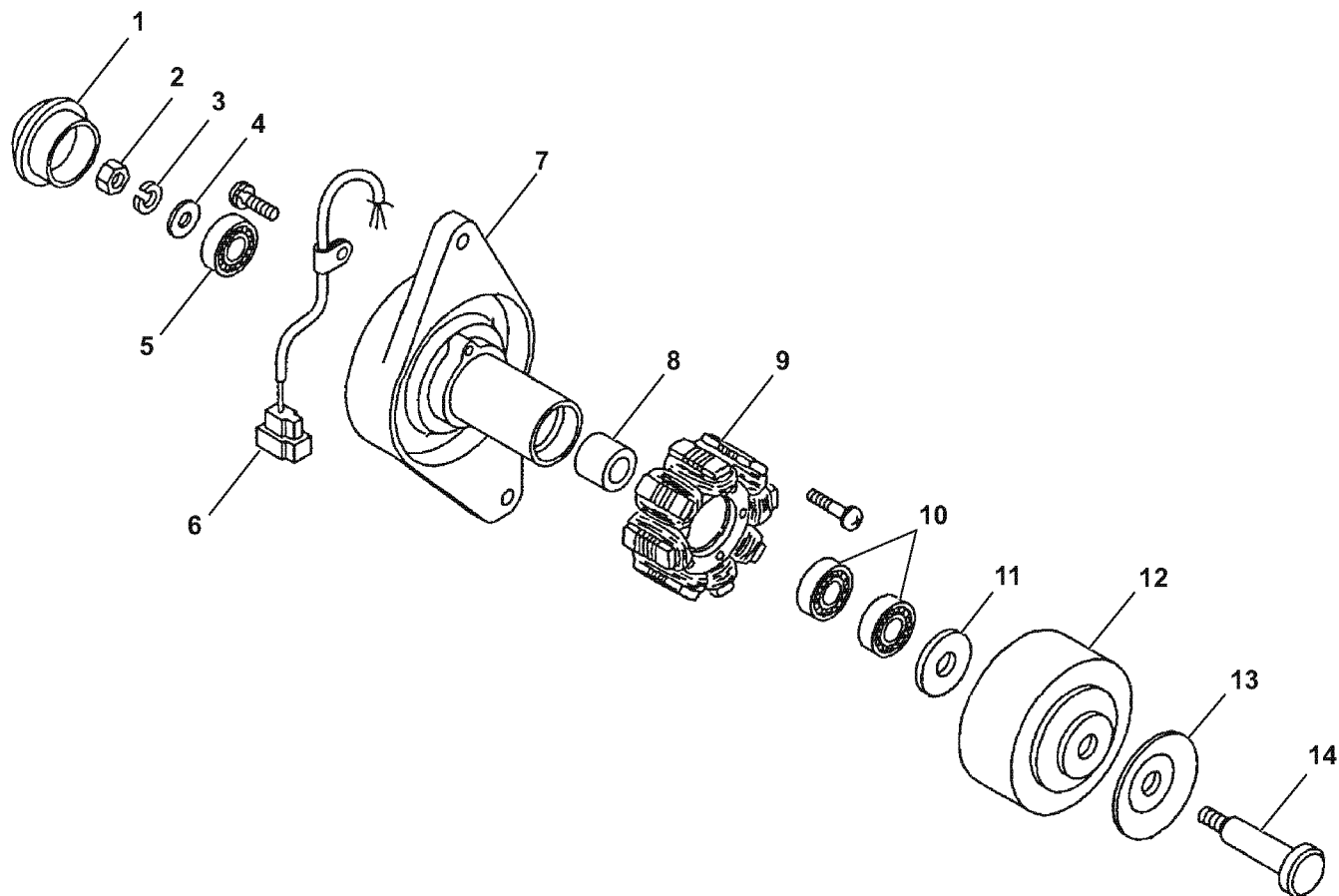

K0002140X

- 1 – Rear cover
- 2 – Nut
- 3 – Lock washer
- 4 – Flat washer
- 5 – Rear bearing
- 6 – Output wire and connector
- 7 – Plate

- 8 – Spacer
- 9 – Stator assembly
- 10 – Front bearing (2 used)
- 11 – Flat washer
- 12 – Flywheel assembly
- 13 – Pulley half
- 14 – Through bolt

Figure 12-20

DYNAMO WIRING DIAGRAM

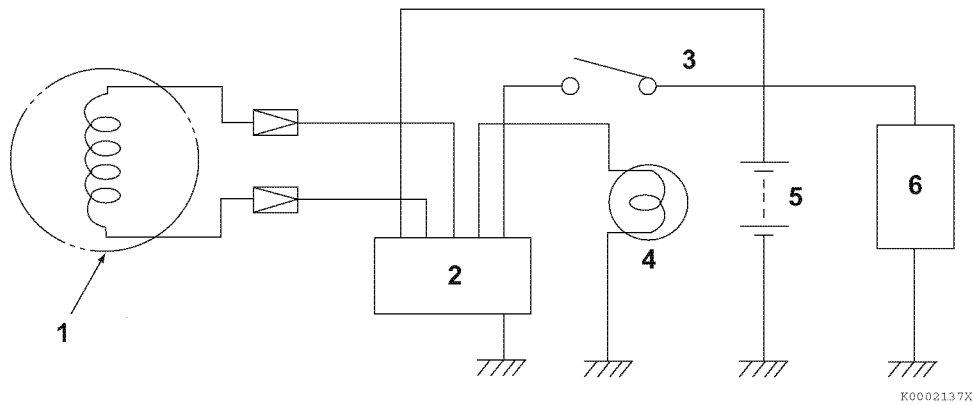

1 –Dynamo
2 –Current limiter
3 –Key switch

4 –Charge lamp (3.4 watts maximum)
5 –Battery
6 –Load

Figure 12-21

OPERATION OF DYNAMO

The dynamo consists of a series of permanent magnets that rotate around a stationary stator coil. The magnets are attached to the flywheel which is rotated via the engine cooling fan drive belt. The resultant output is an AC (alternating current) signal. The AC is converted to DC (direct current) by the current limiter. The current limiter outputs charging DC current to the battery.

DYNAMO STANDARD OUTPUT

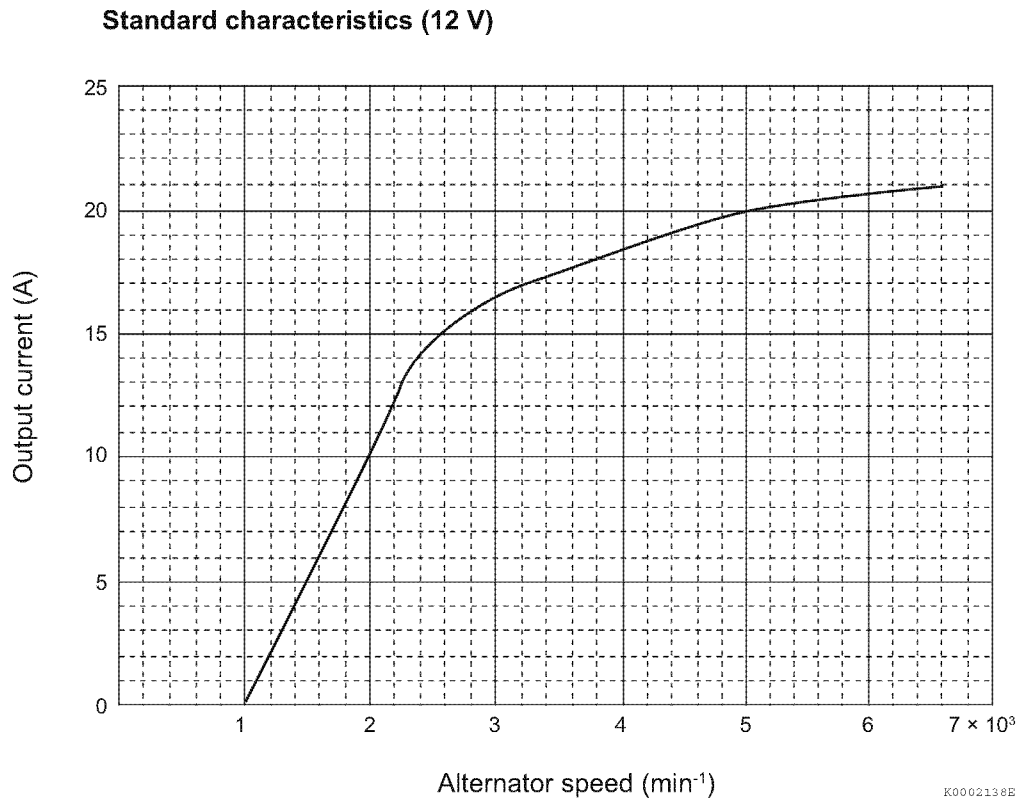

Figure 12-22

TESTING OF DYNAMO

Use a circuit tester or multimeter to perform the following tests.

Testing Stator Coil Continuity

1. Disconnect the dynamo output wire connector.
2. Connect one meter lead to each of the stator wire terminals and read the meter.

Results: The meter reading should indicate continuity. If continuity is not indicated, the windings are open and the stator must be replaced.

Testing Stator Coil Short-to-Ground

1. Disconnect the dynamo output wire connector.
2. Test continuity between each stator wire terminal and engine ground.

Results: The meter reading should infinity. If the meter reading indicates continuity, the windings are shorted to ground and the stator must be replaced.

Testing Dynamo Regulated Output

1. Test and record the battery voltage with the engine not running.
2. Start the engine and operate it at normal operating rpm.
3. Again, check the battery voltage with the engine running.

Results: The meter reading with the engine running must be higher than with the engine not running.

- If results are not correct, test the stator for continuity and shorts to the ground.
- Check the charging system wiring.
- If no problems are found in previous checks, replace the IC regulator.

DYNAMO

Removal of Dynamo

⚠ CAUTION

Pinch Hazard!



Carefully rotate the alternator toward the cylinder block while loosening the V-belt. Failure to comply may result in minor or moderate injury.

1. Disconnect the output wire connector from the dynamo.
2. Loosen the V-belt.
3. Remove the V-belt adjuster from the dynamo bolt (**Figure 12-23, (1)**).
4. Remove the nut (**Figure 12-23, (2)**) from the gear case stud. Remove the dynamo.

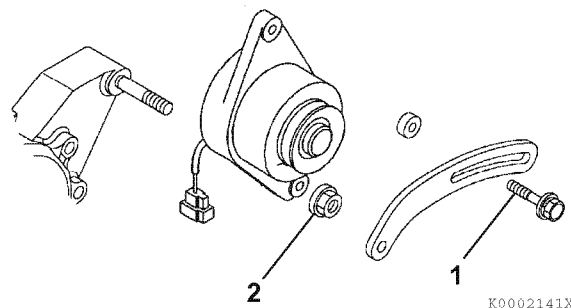

Figure 12-23

Disassembly of Dynamo

1. Remove the rear cover (Figure 12-24, (1)).
2. Remove the nut (Figure 12-24, (2)), lock washer (Figure 12-24, (3)), and flat washer (Figure 12-24, (4)).

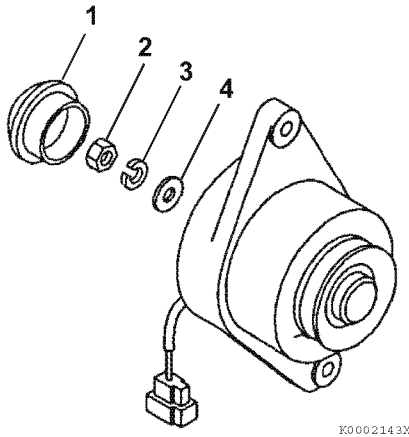

Figure 12-24

3. Remove the through bolt (Figure 12-25, (1)), pulley half (Figure 12-25, (2)), flywheel (Figure 12-25, (3)), flat washer (Figure 12-25, (4)), bearings (Figure 12-25, (5)), and spacer (Figure 12-25, (6)).

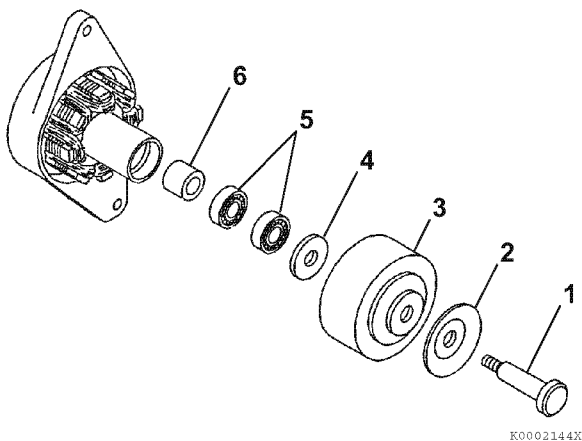

Figure 12-25

4. Remove the screws (Figure 12-26, (1)) and the stator assembly (Figure 12-26, (2)).
5. Remove the rear bearing (Figure 12-26, (3)).

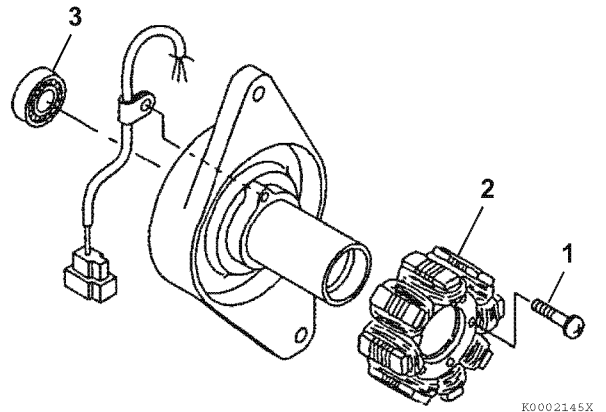

Figure 12-26

Reassembly of Dynamo

1. Reinstall the rear bearing (Figure 12-27, (3)).
2. Reinstall the stator (Figure 12-27, (2)) and screws.

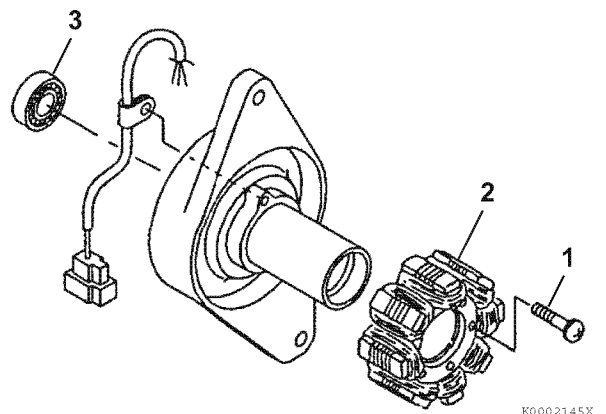

Figure 12-27

3. Reinstall the front bearings (Figure 12-28, (5)) and spacer (Figure 12-28, (6)).
4. Reinstall the flat washer (Figure 12-28, (4)), flywheel (Figure 12-28, (3)), pulley half (Figure 12-28, (2)), and through bolt (Figure 12-28, (1)).

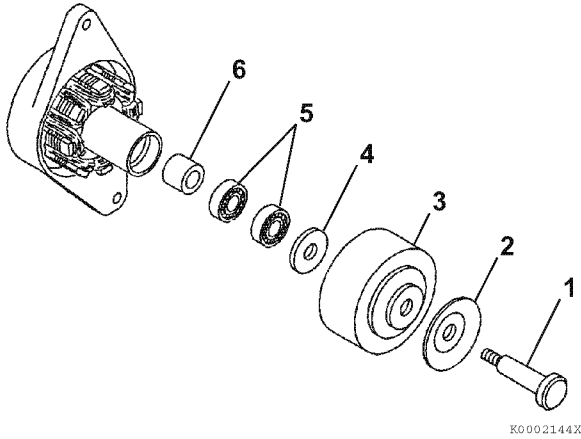

Figure 12-28

5. Reinstall the flat washer (Figure 12-29, (4)), lock washer (Figure 12-29, (3)), and nut (Figure 12-29, (2)). Tighten the nut to the specified torque.
6. Reinstall the rear cap (Figure 12-29, (1)).

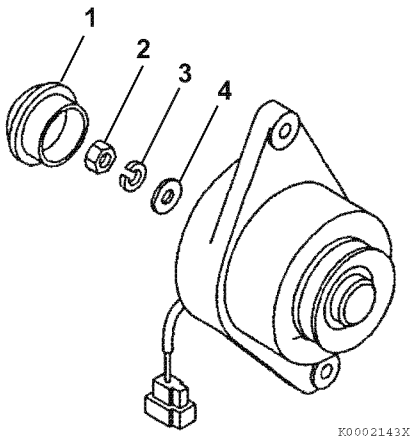

Figure 12-29

Installation of Dynamo

1. Position the dynamo on the gear case. Loosely reinstall the nut (Figure 12-30, (2)) on the gear case stud and the V-belt adjuster bolt (Figure 12-30, (1)).

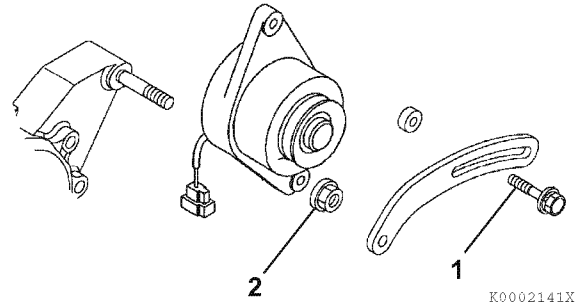

Figure 12-30

2. Reconnect the dynamo output wire connector.
3. Reinstall the V-belt. Tighten the V-belt to the proper tension as described in *Check and adjust cooling fan V-belt on page 5-9*.
4. Start the engine. Listen for any unusual sounds from the alternator.

NOTICE

Do not operate the engine if the alternator is producing unusual sounds. Damage to the alternator will result.

5. Verify that the charge indicator is ON while the engine is operating. If the charge indicator is not ON, repair the problem before operating the engine.

Section 13

ELECTRONIC CONTROL SYSTEM

	Page
Before You Begin Servicing	13-3
Introduction.....	13-3
Electronic Control System	13-4
Diesel Particulate Filter (DPF)	13-5
Electronic Control Harness Connections.....	13-8

This Page Intentionally Left Blank

BEFORE YOU BEGIN SERVICING

Before performing any service procedures within this section, read the following safety information and review the *Safety section on page 3-1*.

INTRODUCTION

None of the components of the electronic control system can be individually repaired. When any component is faulty and needs repair, the entire assembly must be replaced.

ELECTRONIC CONTROL SYSTEM

Model TNV engines come with the Common Rail System and the Exhaust Gas Recirculation (EGR) system to conform to the engine emission regulations (EPA 2012 rules).

The electronic engine control system regulates the exhaust gas recirculation flow rate and the fuel injection volume depending on the engine load and speed signals from the engine controller (E-ECU), so that the exhaust gas is kept clean according to the emission control regulations. **Figure 13-1** illustrates the electronic engine control system.

Also, control the diesel particulate filter (DPF) regeneration mode operation by managing the condition of the DPF (clogging) by controlling the intake throttle.

Features of the electronic engine control system include:

- Engine speed control schemes
Droop control/low-idling speed up/auto deceleration/high-idling speed down/black smoke suppression
- Starting aid
Auto preheating/after heating
- Engine failure detection
- CAN communication with the control system of the driven machine

Although these features are described in section 4-7, whether they are available as options differs among machines/vehicles; for more information, see the instruction manuals for the respective machines/vehicles.

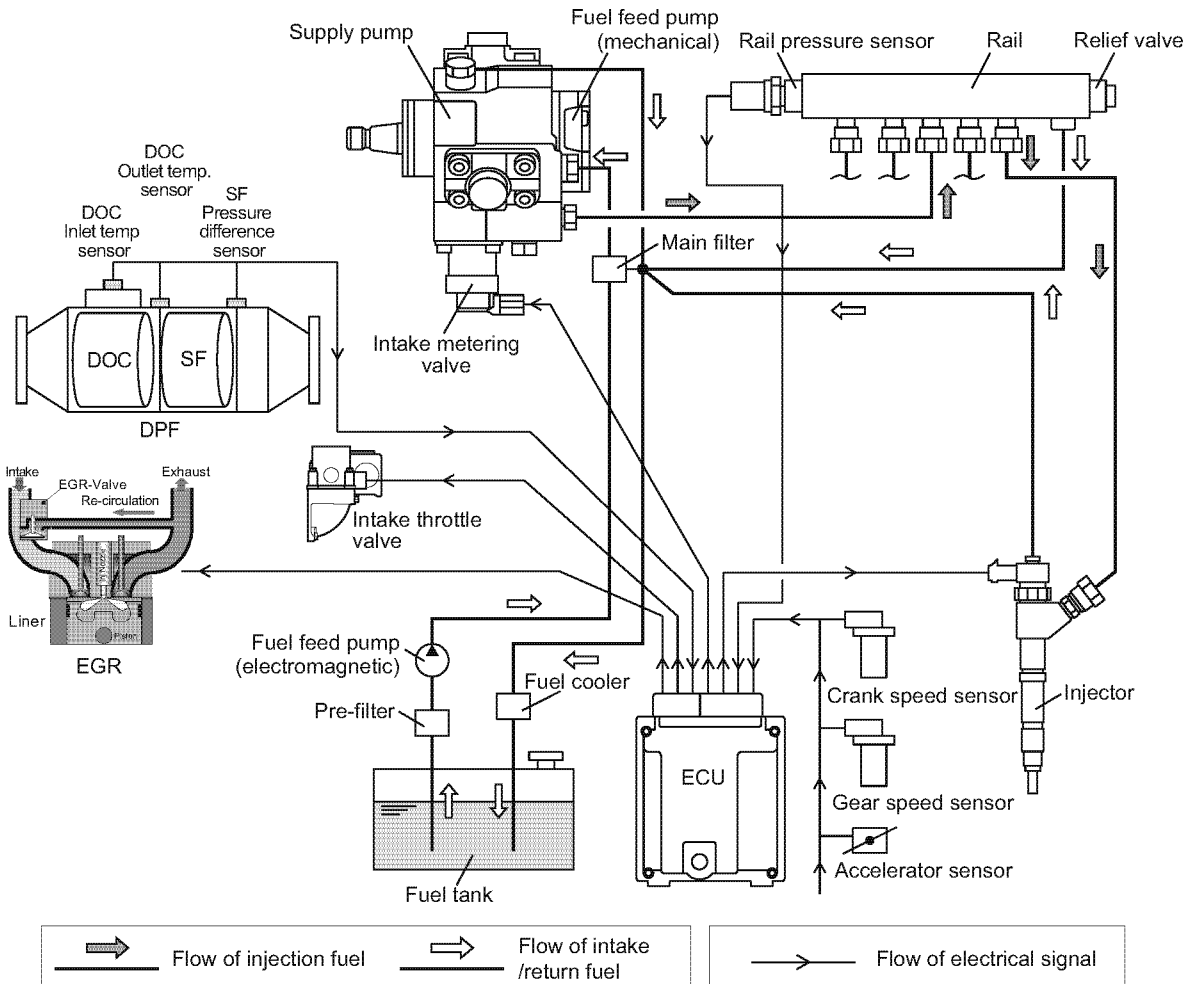

043932-01E00

Figure 13-1

DIESEL PARTICULATE FILTER (DPF)

The DPF consists of the diesel oxidation catalyst (DOC) and the SF, held by a case that sends the exhaust gas to the DOC and the SF. The role of the DPF is to prevent the discharge of PM by breaking down the hazardous constituents with the DOC and collecting the PM with the SF. The PM clogs the SF if left there and the engine performance decreases, so a means of regeneration is required. YANMAR engines use a continuous regeneration method. While continuing the operation, the DPF collects the PM and is regenerated at the same time. To perform the regeneration, the PM collected in the SF is combusted with NO₂ generated in the DOC and O₂ in the exhaust gas. At the same time, the DOC purifies the exhaust gas elements such as HC and CO into H₂O and CO₂.

Apart from the PM, ash also collects in the SF. This comes mostly from metallic components in the additives to the lubricating oil. Part of the lubricating oil is burnt in the high temperature combustion chamber and exhausted along with the combustion gas. In that case, metallic components are collected together with the PM in the SF. However, because the amount of ash is very little compared to the PM, it does not clog the SF immediately. Because ash is a metallic component, it cannot be combusted in the DPF for treatment like the PM. Therefore, ash is over-accumulated in the SF over a long period of time. This increases the pressure loss and has adverse effects on the engine. In this case, maintenance must be performed to remove the SF with the accumulated ash from the DPF. Yanmar recommends to do this maintenance once every 3,000 operating hours.

Be sure to use the specified fuel and lubricating oil so that the DPF can fulfill its function. For fuel, use diesel fuel (ultra-low sulfur) with a sulfur mass of 15 ppm or lower. If you use a fuel other than the specified, performance of the catalyst contained in the DOC deteriorates rapidly due to sulfur. Because of this, the DPF cannot develop its regeneration capabilities and PM accumulates easier. This leads to increased fuel consumption and a deterioration of general engine receptiveness caused by decreased engine performance and frequent switching to the regeneration mode.

For lubricating oil, use low ash oil. If you use any other than the specified lubricating oil, a large amount of ash is vented through the exhaust and the DPF will clog within a short period of time. This will not only cause the engine output to decrease and the fuel costs to increase, but also makes earlier maintenance of the SF necessary.

■ Overview of DPF regeneration control

Electrical components such as the DPF differential pressure sensor, temperature sensor, and intake throttle are installed in the DPF. If the DPF cannot perform continuous regeneration due to low load operation, the ECU uses these electrical components to control assisted DPF regeneration (DPF regeneration control) automatically to prevent PM from over-accumulating.

■ Self-regeneration

Regeneration without the use of regeneration assistance devices (normal)

During the operation at high speed or high load, the exhaust temperature rises and PM is continuously combusted and eliminated.

■ Assisted regeneration

Regeneration with the use of assistance devices (e.g. the intake throttle)

When the differential pressure in the SF inlet/outlet in the DPF rises, the differential pressure sensor installed to the DPF detects the increase. The ECU commands the intake throttle to open the throttle according to the detected differential pressure to adjust the amount of engine intake air. The ECU also controls the regeneration by performing after-injection to increase the exhaust temperature. At this time, the EGR valve is closed.

■ Reset regeneration

Regeneration with the combined use of assisted regeneration and post-injection

Approximately every 100 hours of operation, the assisted regeneration and post-injection are automatically used together to control regeneration by increasing the exhaust temperature to burn off and remove PM.

These automatic regenerations can be performed during operation. No special operation is required for the operator. The following conditions may occur due to the characteristics of the DPF system, but they are not malfunctions.

- The engine sound may change during the idling operation at no load.
- White smoke may be discharged from the exhaust pipe right after starting a cold engine or during acceleration.
This is due to discharge of water vapor. When the exhaust temperature increases, the white smoke disappears.
- The exhaust gas is purified through the catalyst installed in the DPF, so the smell of the exhaust gas is different from the exhaust gas of a conventional diesel engine.

CAUTION

- **During reset regeneration, post-injection is used and fuel is burned directly inside the DPF (burned by chemical reaction inside the DOC). Through this heat, regeneration occurs inside the SF, but the combustion increases the temperature of the exhaust gas to close to 600 °C (1112 °F). Be careful that neither people nor flammable materials are near the exhaust gas outlet.**
- **Post-injection can cause the fuel consumption to increase by a small amount.**
- **Through this genuine YANMAR regeneration method, the dilution of the lubricating oil with fuel caused by the post-injection is kept to a minimum, but some dilution is possible for low-load operation (low temperature exhaust gas) of fork lifters or similar machines. Make sure that you do a daily check of the oil level.**

■ Stationary regeneration

Although the DPF performs the regeneration control, if the operation conditions with idling at no load and low speed/low load operation are frequently repeated, the PM may not be regenerated. If the ECU determines that performing the stationary regeneration is required at this time, the DPF regeneration request lamp lights up.

If the DPF regeneration request lamp is lit, immediately conduct the stationary regeneration by performing the following operation.

If the operation is continued with the DPF regeneration request lamp lit up, an excessive amount of PM will accumulate. Abnormal combustion of PM may cause fire and damage to the DPF.

Operation procedures of stationary regeneration

1. Move to a well-ventilated and safe location.
2. Move the accelerator lever to the lowest position and operate the engine in idling.
Note: If the DPF regeneration prohibition switch is installed, turn the DPF regeneration prohibition switch to "Regeneration Permitted".
3. Operate the interlock mechanism including the parking brake and activate the interlock function.

Note: When the ECU verifies that the interlock mechanism is enabled with the regeneration interlock switch, the DPF regeneration approval lamp starts blinking.

4. Press the DPF regeneration request switch for 1 second or longer to start the stationary regeneration.
 - When the stationary regeneration starts, the engine speed increases gradually to high idle speed. Then the reset regeneration is performed at that operation condition.
 - When the stationary regeneration starts, the DPF regeneration request lamp turns off, the DPF regeneration approval lamp switches from blinking to continuously lit, and the exhaust temperature warning lamp lights up.
 - The stationary regeneration is complete after approximately 25 to 30 minutes.
 - If you want to interrupt the stationary regeneration, perform one of the following operations.
 - Turn the interlock switch to "Regeneration Disabled".
 - Turn the DPF regeneration prohibition switch to "Regeneration Prohibited".
 - Raise the accelerator lever above the lowest position.
 - Turn off the power switch.
5. When the above-mentioned time has elapsed, the engine speed decreases to low idling, the regeneration approval lamp and the exhaust temperature warning lamp turn off, and the stationary regeneration is complete.

■ Outline of Diesel Particulate Filter (DPF)

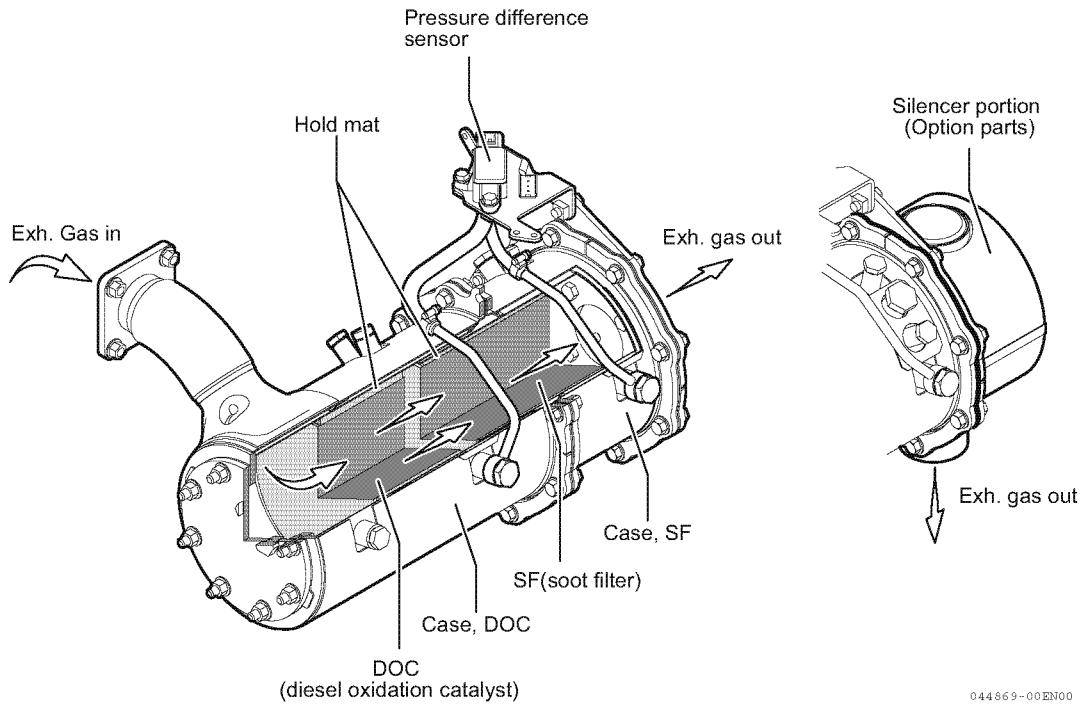

Figure 13-2

■ DPF service

DOC: Maintenance-free parts
Replacement only, every 9000 hrs of operation

SF: Maintenance is required parts
Perform the cleaning every 3000 hrs of operation

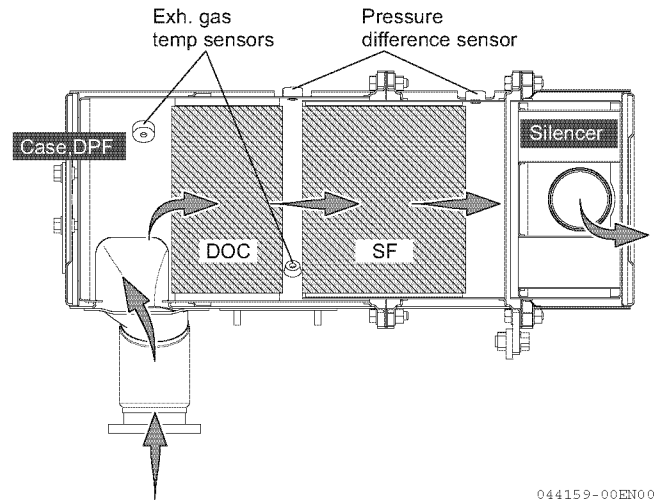
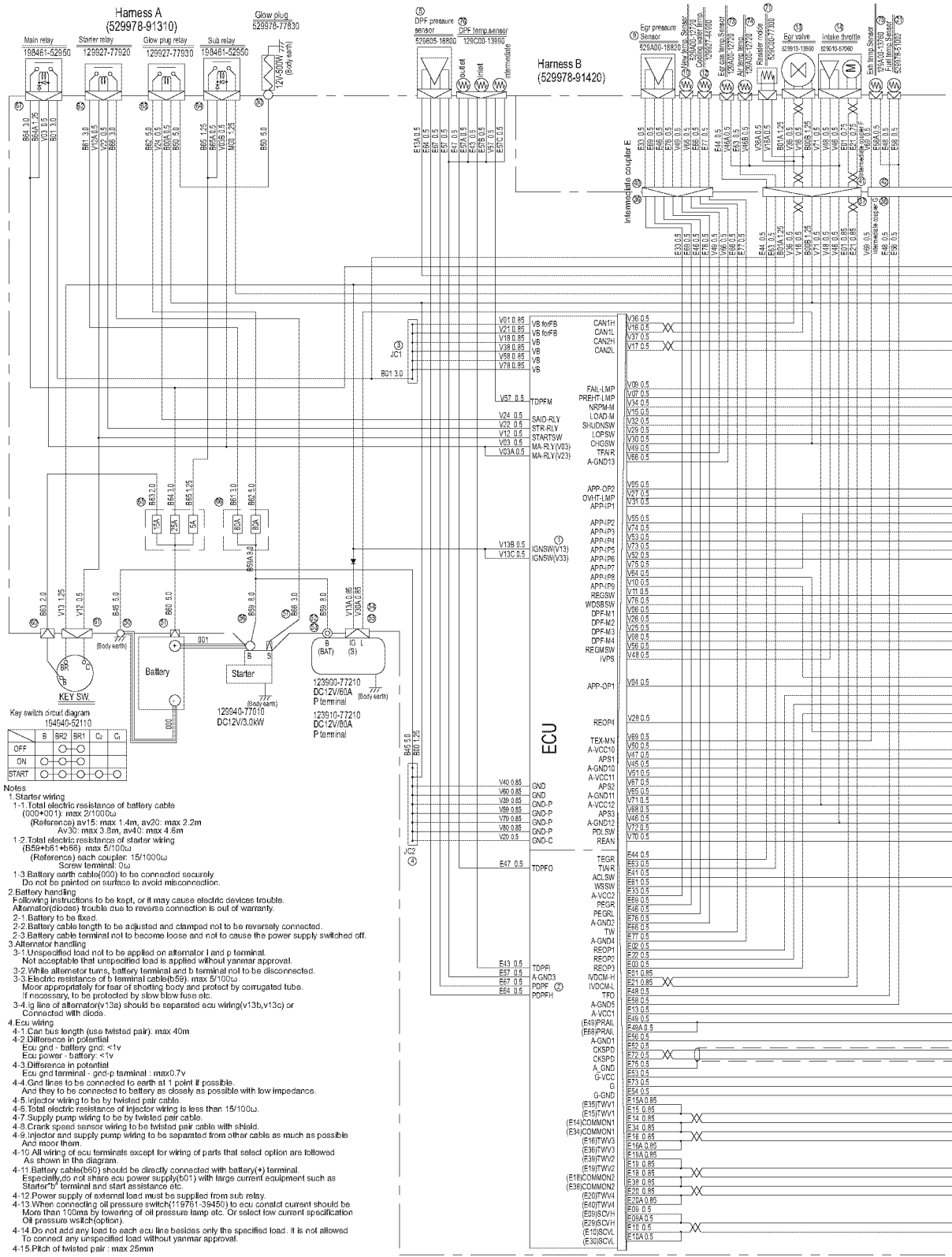
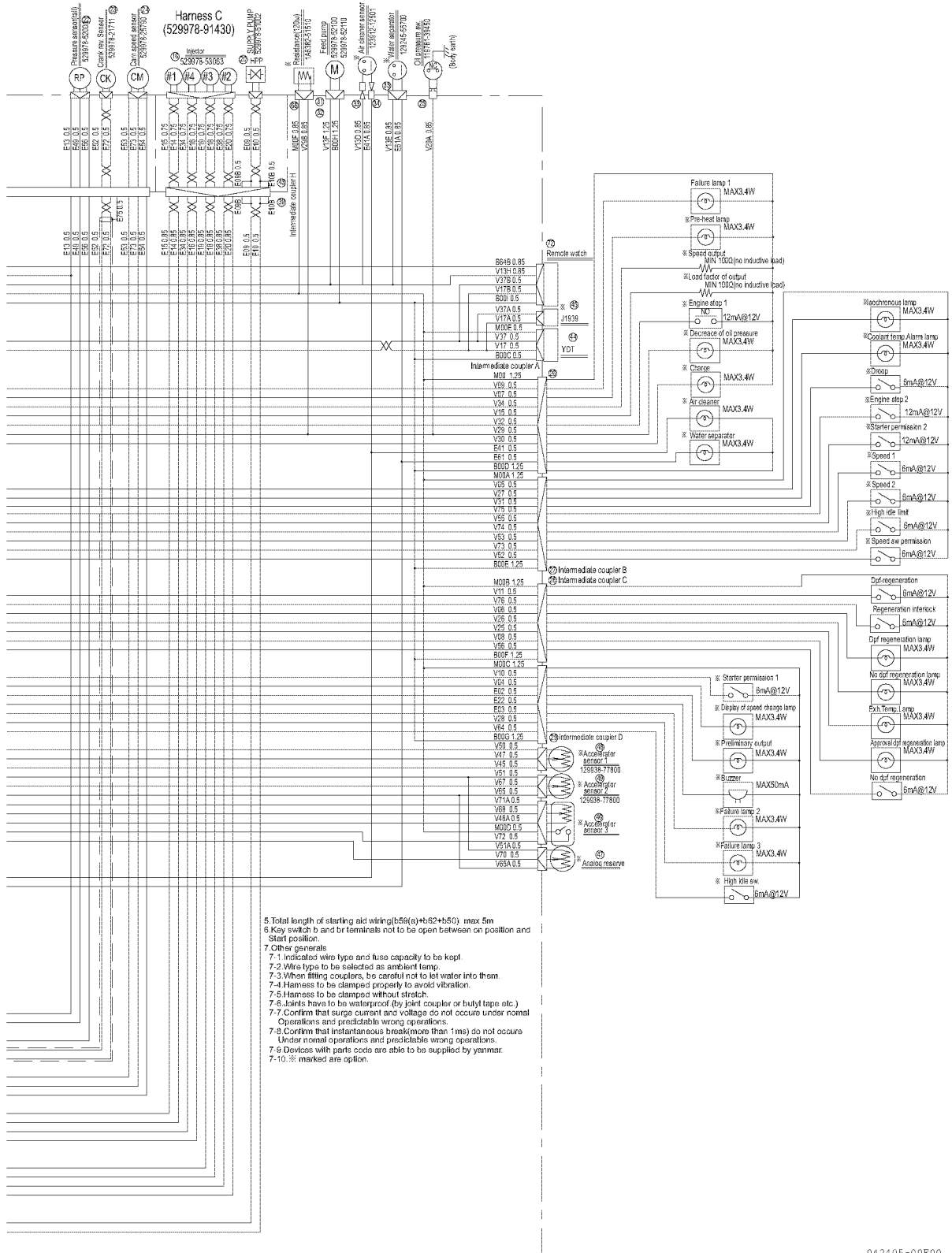

Figure 13-3

Item	Engine type	Emission warranty (Useful life)	Periodic maintenance interval	
			Replacement	Clean
DOC	19 - 37 kW	5000 hrs or 7 years, whichever comes first.	Every 9000 hrs of operation	N/A
	³ 37 kW	8000 hrs or 10 years, whichever comes first		
SF	19 - 37 kW	5000 hrs or 7 years, whichever comes first.	Every 9000 hrs of operation	Every 3000 hrs of operation
	³ 37 kW	8000 hrs or 10 years, whichever comes first		

ELECTRONIC CONTROL HARNESS CONNECTIONS





- 5. Total length of starting aid wiring (b56(a)+b62+b50) max 5m
- 6. Key switch b and br terminals not to be open between on position and Start position.
- 7. Other generals
 - 7-1. Indicated wire type and fuse capacity to be kept.
 - 7-2. Wire type to be selected as ambient temp.
 - 7-3. When fitting couplers, be careful not to let water into them.
 - 7-4. Harness to be damped properly to avoid vibration.
 - 7-5. Harness to be clamped without stretch.
 - 7-6. Joints have to be waterproof (by joint coupler or butyl tape etc.)
 - 7-7. Confirm that surge current and voltage do not occur under normal Operations and predictable wrong operations.
 - 7-8. Confirm that instantaneous break (more than 1ms) do not occur Under normal operations and predictable wrong operations.
 - 7-9. Devices with parts code are able to be supplied by yanmar.
 - 7-10. ※ marked are option.

042405-00E00

No.	Kind of wire	Cross section	Wire color	Circuit mark	Terminal	Circuit mark	Terminal	Circuit mating tip	Remarks
001	AVS	5.0	R	B60		B60		51 65	
002	AVS	3.0	R	B01		B01		67 3	
003	AVSS	1.25	R			B01A		37	
004	AVSS	0.85	R	V01		V01	Gold	3 1	
005	AVSS	0.85	R	V21		V21	Gold	3 1	
006	AVSS	0.85	R	V18		V18	Gold	3 1	
007	AVSS	0.85	R	V38		V38	Gold	3 1	
008	AVSS	0.85	R	V58		V58	Gold	3 1	
009	AVSS	0.85	R	V78		V78	Gold	3 1	
010	AVSS	2.0	RW	B63		B63		65 60	
011	AVSS	3.0	RY	B64		B64		65 67	
012	AVSS	1.25	RY			B64A		67	
013	AVSS	0.85	RY			B64B		72	
014	AVSS	0.5	G	V03		V03	Gold	67 1	
015	AVSS	0.5	G			V03A	Gold	1	
016	AVSS	0.5	G			V03B		64	
017	AVSS	1.25	Y	B65		B65		65 64	
018	AVSS	0.5	Y			B65A		64	
019	AVSS	1.25	O	V13		V13		61 31	
020	AVSS	0.85	O			V13A		54	
021	AVSS	0.5	O			V13B	Gold	1	
022	AVSS	0.5	O			V13C	Gold	1	
023	AVSS	0.85	O			V13D		33	
024	AVSS	0.85	O			V13E		35	
025	AVSS	1.25	O			V13F		32	
026	AVSS	0.85	O			V13G		55	
027	AVSS	0.85	O			V13H		72	
028	AVSS	0.5	G	V12		V12	Gold	61 1	
029	AVSS	0.5	G			V12A		62	
030	AVS	5.0	B	B45		B45		4 50	
031	AVSS	0.85	B	V40	Gold	V40		1 4	
032	AVSS	0.85	B	V60	Gold	V60		1 4	
033	AVSS	0.85	B	V39	Gold	V39		1 4	
034	AVSS	0.85	B	V59	Gold	V59		1 4	
035	AVSS	0.85	B	V79	Gold	V79		1 4	
036	AVSS	0.85	B	V80	Gold	V80		1 4	
037	AVSS	0.5	B	V20	Gold	V20		1 4	
038	AVSS	1.25	B	B00		B00		4 31	
039	AVSS	0.5	B			B00A		63	
040	AVSS	1.25	B			B00B		37	
041	AVSS	0.5	B			B00C		44	
042	AVSS	1.25	B			B00D		26	
043	AVSS	1.25	B			B00E		27	
044	AVSS	1.25	B			B00F		28	
045	AVSS	1.25	B			B00G		29	
046	AVSS	1.25	B			B00H		32	
047	AVSS	0.5	B			B00I		72	
048	AV	8.0	W	B59		B59		56 52	
049	AV	8.0	W			B59A		66	
050	AV	8.0	W			B59B		53	
051	AVS	3.0	BrY	B61		B61		66 62	
052	AVS	5.0	Br	B62		B62		66 63	
053	AVS	3.0	W	B66		B66		62 57	
054	AVSS	0.5	P	V22	Gold	V22		1 62	
055	AVSS	0.5	LW	V24	Gold	V24		1 63	
056	AVS	5.0	R	B50		B50		30 63	
057	AVSS	1.25	R	M00		M00		64 26	
058	AVSS	1.25	R			M00A		27	
059	AVSS	1.25	R			M00B		28	
060	AVSS	1.25	R			M00C		29	
061	AVSS	0.5	R			M00D		46	
062	AVSS	0.5	R			M00E		44	
063	AVSS	0.85	R			M00F		68	
064	AVSS	0.5	RG	V09	Gold	V09		1 26	
065	AVSS	0.5	L	V07	Gold	V07		1 26	
066	AVSS	0.5	Y	V34	Gold	V34		1 26	
067	AVSS	0.5	G	V15	Gold	V15		1 26	
068	AVSS	0.5	P	V32	Gold	V32		1 26	
069	AVSS	0.5	Br	V29	Gold	V29		1 26	
070	AVSS	0.85	Br			V29A		25	
071	AVSS	0.85	Br			V29B		68	
072	AVSS	0.5	RW	V30	Gold	V30		1 26	
073	AVSS	0.85	RW			V30A		54	
074	AVSS	0.85	RW			V30B		55	
075	AVSS	0.5	L	E41	Gold	E41		2 26	
076	AVSS	0.85	L			E41A		34	
077	AVSS	0.5	GY	E61	Gold	E61		2 26	
078	AVSS	0.85	GY			E61A		35	
079	AVSS	0.5	W	V05	Gold	V05		1 27	
080	AVSS	0.5	RW	V27	Gold	V27		1 27	
081	AVSS	0.5	Br	V31	Gold	V31		1 27	
082	AVSS	0.5	G	V75	Gold	V75		1 27	
083	AVSS	0.5	L	V55	Gold	V55		1 27	
084	AVSS	0.5	Y	V74	Gold	V74		1 27	
085	AVSS	0.5	P	V53	Gold	V53		1 27	
086	AVSS	0.5	LW	V73	Gold	V73		1 27	
087	AVSS	0.5	BrW	V52	Gold	V52		1 27	
088	AVSS	0.5	LW	V11	Gold	V11		1 28	
089	AVSS	0.5	Y	V76	Gold	V76		1 28	
090	AVSS	0.5	Br	V06	Gold	V06		1 28	
091	AVSS	0.5	P	V26	Gold	V26		1 28	
092	AVSS	0.5	W	V25	Gold	V25		1 28	
093	AVSS	0.5	G	V08	Gold	V08		1 28	
094	AVSS	0.5	O	V56	Gold	V56		1 28	
095	AVSS	0.5	W	V10	Gold	V10		1 29	
096	AVSS	0.5	G	V04	Gold	V04		1 29	
097	AVSS	0.5	Br	E02	Gold	E02		2 29	
098	AVSS	0.5	P	E22	Gold	E22		2 29	
099	AVSS	0.5	P	E03	Gold	E03		2 29	
100	AVSS	0.5	Y	V28	Gold	V28		1 29	
101	AVSS	0.5	RW	V64	Gold	V64		1 29	
102	AVSS	0.5	R	E33	Gold	E33		2 36	
103	AVSS	0.5	Y	E69	Gold	E69		2 36	
104	AVSS	0.5	W	E46	Gold	E46		2 36	
105	AVSS	0.5	S	E76	Gold	E76		2 36	
106	AVSS	0.5	P	V49	Gold	V49		1 36	
107	AVSS	0.5	BW	V66	Gold	V66		1 36	

No.	Kind of wire	Cross section	Wire color	Circuit mark	Terminal	Circuit mark	Terminal	Circuit mating tip	Remarks
108	AVSS	0.5	G	E66	Gold	E66		2 36	
109	AVSS	0.5	L	E77	Gold	E77		2 36	
110	AVSS	0.5	P	V36	Gold	V36		1 37	V16 twisted pair
111	AVSS	0.5	L	V16	Gold	V16		1 37	V36 twisted pair
112	AVSS	0.5	R	V71	Gold	V71		1 37	
113	AVSS	0.5	R			V71A		46	
114	AVSS	0.5	G	V48	Gold	V48		1 37	
115	AVSS	0.5	Br	V46	Gold	V46		1 37	
116	AVSS	0.5	Br			V46A		46	
117	AVSS	0.85	Y	E01	Gold	E01		2 37	E21 twisted pair
118	AVSS	0.85	LW	E21	Gold	E21		2 37	E01 twisted pair
119	AVSS	0.5	L	E48	Gold	E48		2 38	
120	AVSS	0.5	BrW	E58	Gold	E58		2 38	
121	AVSS	0.5	R	E13	Gold	E13		2 38	
122	AVSS	0.5	R			E13A	Gold	2 38	
123	AVSS	0.5	G	E49	Gold	E49		38 2	
124	AVSS	0.5	G			E49A	Gold	2	
125	AVSS	0.5	BW	E56	Gold	E56		2 38	
126	AVSS	0.5	P	E52	Gold	E52		2 38	Shield and twist with e72
127	AVSS	0.5	O	E72	Gold	E72		2 38	Shield and twist with e52
128	AVSS	0.5	B	E75	Gold	E75		2 38	Shield with e52 e72
129	AVSS	0.5	RW	E53	Gold	E53		2 38	
130	AVSS	0.5	L	E73	Gold	E73		2 38	
131	AVSS	0.5	BL	E54	Gold	E54		2 38	
132	AVSS	0.85	WL	E15		E15	Gold	39 2	E14 twisted pair
133	AVSS	0.85	WL			E15A	Gold	2	Connected to e15
134	AVSS	0.85	R	E14	Gold	E14		2 39	E15 twisted pair Connected to e34 and a
135	AVSS	0.85	R	E34	Gold	E34		2 39	E16 twisted pair Connected to e14 and a
136	AVSS	0.85	Y	E16		E16	Gold	39 2	E34 twisted pair
137	AVSS	0.85	Y			E16A	Gold	2	Connected to e16
138	AVSS	0.85	W	E19		E19	Gold	39 2	E18 twisted pair
139	AVSS	0.85	W			E19A	Gold	2	Connected to e19
140	AVSS	0.85	L	E18	Gold	E18		2 39	E19 twisted pair Connected to e38 and a
141	AVSS	0.85	L	E38	Gold	E38		2 39	E20 twisted pair Connected to e18 and a
142	AVSS	0.85	WL	E20		E20	Gold	39 2	E38 twisted pair
143	AVSS	0.85	WL			E20A	Gold	2	Connected to e20
144	AVSS	0.5	Y	E09	Gold	E09		2 39	E10 twisted pair
145	AVSS	0.5	Y			E09A	Gold	2	Connected to e09
146	AVSS	0.5	Y			E09B		39	Connected to e09
147	AVSS	0.5	P	E10	Gold	E10		2 39	E09 twisted pair
148	AVSS	0.5	P			E10A	Gold	2	Connected to e10
149	AVSS	0.5	P			E10B		39	Connected to e10
150	AVSS	0.5	G	E64	Gold	E64	Gold	2 5	
151	AVSS	0.5	L	E67	Gold	E67	Gold	2 5	
152	AVSS	0.5	B	E57	Gold	E57	Gold	2 5	
153	AVSS	0.5	B			E57A		76	
154	AVSS	0.5	B			E57B		76	
155	AVSS	0.5	B			E57C		76	
156	AVSS	0.5	RW	E43	Gold	E43		2 76	
157	AVSS	0.5	Br	V57	Gold	V57		1 76	
158	AVSS	0.5	Y	V37	Gold	V37		1 44	V17 twisted pair
159	AVSS	0.5	Y			V37A		45	Connected to v37
160	AVSS	0.5	Y			V37B		72	Connected to v37
161	AVSS	0.5	L	V17		V17		1 44	V37 twisted pair
162	AVSS	0.5	L			V17A		45	Connected to v17
163	AVSS	0.5	L			V17B		72	Connected to v17
164	AVSS	0.5	R	V50	Gold	V50	Gold	1 48	
165	AVSS	0.5	P	V47	Gold	V47	Gold	1 48	
166	AVSS	0.5	B	V45	Gold	V45	Gold	1 48	
167	AVSS	0.5	LW	V51	Gold	V51	Gold	1 49	
168	AVSS	0.5	LW			V51A	Gold	47	
169	AVSS	0.5	G	V67	Gold	V67	Gold	1 49	
170	AVSS	0.5	Y	V65	Gold	V65	Gold	1 49	
171	AVSS	0.5	Y			V65A	Gold	47	
172	AVSS	0.5	O	V68	Gold	V68		1 46	
173									

No.	Kind of wire	Cross section	Wire color	Circuit mark	Terminal	Circuit mark	Terminal	Circuit mating tip	Remarks
189	AVSSX	0.5	P				V36A	71	
190	AVSSX	0.5	L	V16		V16		13 41	V36 twisted pair
191	AVSSX	0.5	L			V16A		71	
192	AVSSX	1.25	B	B00B		B00B		13 41	
193	AVSSX	0.5	R	V71	Gold	V71		14 41	
194	AVSSX	0.5	G	V48	Gold	V48		14 41	
195	AVSSX	0.5	Br	V46	Gold	V46		14 41	
196	AVSSX	0.5	Br			V46A	Gold	73	
197	AVSSX	0.5	Br			V46B	Gold	74	
198	AVSSX	0.75	Y	E01		E01		14 41	E21 twisted pair
199	AVSSX	0.75	LW	E21		E21		14 41	E01 twisted pair
200	AVSSX	0.5	L	E48	Gold	E48		21 42	
201	AVSSX	0.5	BrW	E58	Gold	E58		21 42	
202	AVSSX	0.5	BrW			E58A		75	
203	AVSSX	0.5	R	E13	Gold	E13		22 42	
204	AVSSX	0.5	G	E49	Gold	E49		22 42	
205	AVSSX	0.5	BW	E56	Gold	E56		22 42	
206	AVSS	0.5	P	E52		E52		23 42	E72 twisted pair
207	AVSS	0.5	O	E72		E72		23 42	E52 twisted pair
208	AVSSX	0.5	RW	E53		E53		24 42	
209	AVSSX	0.5	L	E73		E73		24 42	
210	AVSSX	0.5	BL	E54		E54		24 42	
211	AVSSX	0.5	YG	V69	Gold	V69		75 42	
212	AVSSX	0.5	RW	E44	Gold	E44		73 41	
213	AVSSX	0.5	LY	E63	Gold	E63		74 41	
214	AVSSX	0.75	WL	E15		E15		16 43	E14 twisted pair
215	AVSSX	0.75	R	E14		E14		16 43	E15 twisted pair
216	AVSSX	0.75	R	E34		E34		16 43	E16 twisted pair
217	AVSSX	0.75	Y	E16		E16		16 43	E34 twisted pair
218	AVSSX	0.75	W	E19		E19		16 43	E18 twisted pair
219	AVSSX	0.75	L	E18		E18		16 43	E19 twisted pair
220	AVSSX	0.75	L	E38		E38		16 43	E20 twisted pair
221	AVSSX	0.75	WL	E20		E20		16 43	E38 twisted pair
222	AVSSX	0.5	Y	E09		E09		20 43	E10 twisted pair
223	AVSSX	0.5	Y			E09B		43	Connected to e09
224	AVSSX	0.5	P	E10		E10		20 43	E09 twisted pair
225	AVSSX	0.5	P			E10B		43	Connected to e10

042421-00E00

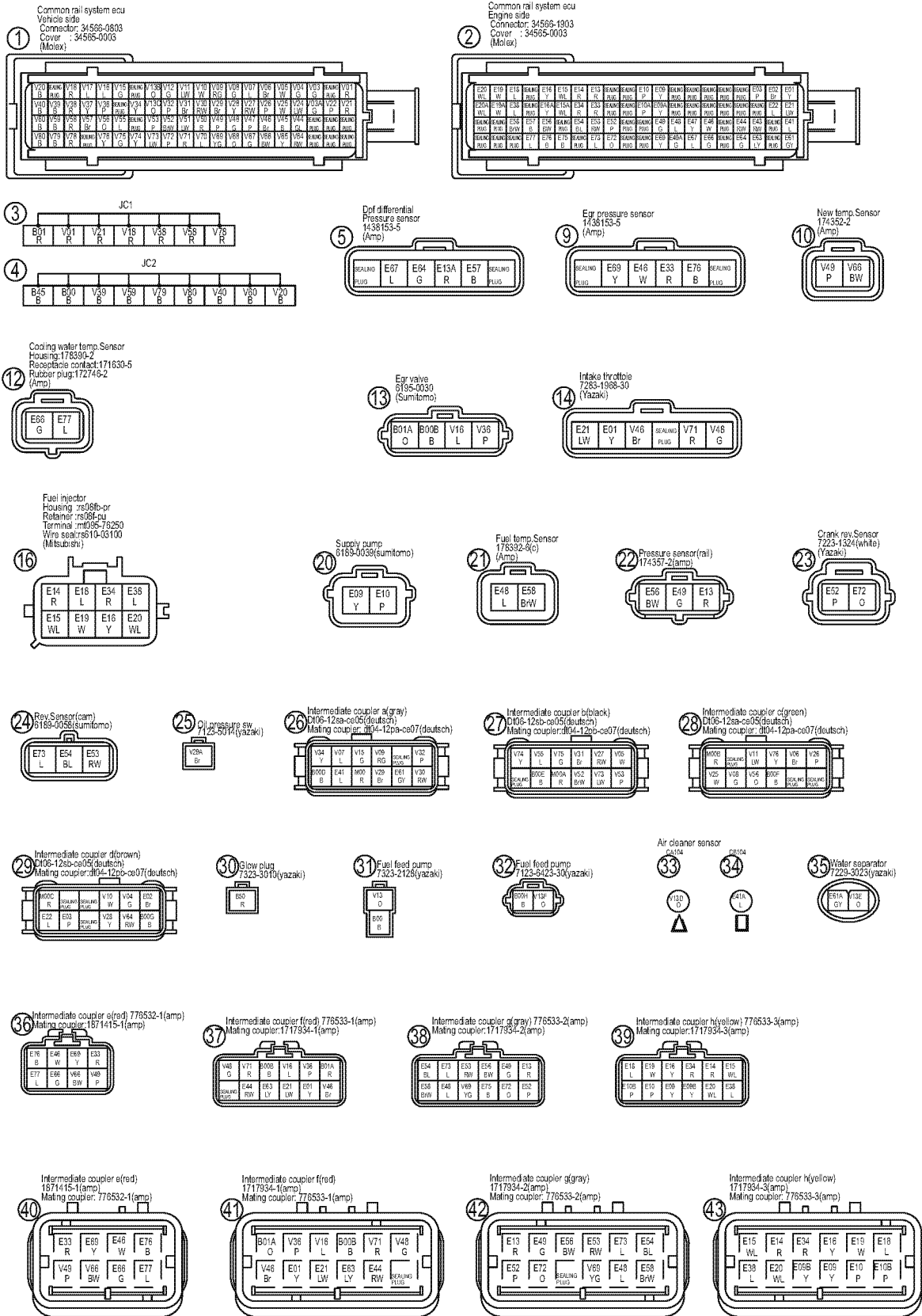

This Page Intentionally Left Blank

Section 14

ELECTRIC WIRING

	Page
Electric Wiring Precautions	14-3
Electrical Wire Resistance	14-4
Battery Cable Resistance.....	14-5
Electrical Wire Sizes - Voltage Drop	14-6
Conversion of AWG to European Standards.....	14-7

This Page Intentionally Left Blank

ELECTRIC WIRING PRECAUTIONS

Failure to follow these precautions may result in the failure of an electrical component and the loss of warranty coverage on that item as well as related items. Make sure that all users read and understand these precautions.

NOTICE

Do not reverse the positive (+) and negative (-) ends of the battery cable. The alternator diode and stator coil will be damaged.

NOTICE

When the battery indicator goes out, it should not come on again. The battery indicator only comes on during operation if the alternator fails. However, if an LED is used in the battery indicator, the LED will shine faintly during normal operation.

NOTICE

Make sure that the combined total resistance of the battery cable in both directions between the starter motor and the battery is within the value indicated in the *Battery Cable Resistance chart* in the *Electric Wiring Section* of this manual. The starter motor will malfunction and fail if the resistance is higher than the specified value.

NOTICE

Removing the battery cables or the battery while the engine is operating may cause damage to the current limiter depending on the electrical equipment being used. This situation could cause loss of control of output voltage. The continuous high voltage of 23 - 24 V (for 5000 min⁻¹ (rpm) dynamo) will damage the current limiter and other electrical equipment.

NOTICE

Reversing the battery cable connections at the battery or on the engine will destroy the SCR diode in the current limiter. This will cause the charging system to malfunction and may cause damage to the electrical harnesses.

ELECTRICAL WIRE RESISTANCE

AWG	Metric nominal mm ²	Ohms/foot resistance
20	0.5	0.009967
18	0.8	0.006340
16	1.25	0.004359
14	2	0.002685
12	3	0.001704
10	5	0.001073
8	8	0.000707
6	15	0.000421
4	20	0.000270
2	30	0.000158
1	40	0.000130
0 (1/0)	50	0.000103
00 (2/0)	60	0.000087
000 (3/0)	85	0.000066
0000 (4/0)	100	0.000051

Wiring voltage drop should not exceed 5 % $[0.05] \times 12 \text{ volts} = 0.6 \text{ volts}$.

Voltage drop = Current [Amps] \times Length of wire [feet] \times Resistance per foot Ω

Example:

Current draw of 100 Amps \times 3 feet of 4 AWG wire

100 Amps \times 3 feet \times 0.000270 = 0.08 volts [voltage drop]

BATTERY CABLE RESISTANCE

AWG	mm ²	Maximum total battery cable length (positive cable + negative cable + a*) 12 V starter motor output			
		Less than 2.68 HP (2 kW)		Greater than 2.68 HP (2 kW)	
		m	ft	m	ft
6	15	1.5	4.75	N/A	N/A
4	20	2.3	7.4	N/A	N/A
2	30	3.8	12.6	2.3	7.5
1	40	4.6	15.3	2.8	9.2
0 (1/0)	50	5.9	19.5	3.5	11.6
00 (2/0)	60	7.0	22.8	4.2	13.7
000(3/0)	85	9.3	30.5	5.6	18.3
0000 (4/0)	100	11.9	39.0	7.1	23.4
00000 (5/0)	125	N/A	N/A	8.3	27.3
000000 (6/0)	150	N/A	N/A	10.1	33.3

Note:

- Total allowable resistance of the complete battery cable circuit (positive cable + negative cable + a*) (a*: Resistance (Ω) of a battery switch or other electrical equipment having high resistance).
- For starter motors of less than 2.68 HP (2 kW): the total resistance must be less than 0.002 Ω .
For starter motors of greater than 2.68 HP (2 kW): the total resistance must be less than 0.0012 Ω .

ELECTRICAL WIRE SIZES - VOLTAGE DROP

Total current on circuit in amps	Length of conductor from source of current to device and back to source (in feet)																			
	10	15	20	25	30	40	50	60	70	80	90	100	110	120	130	140	150	160	170	
12 v	Wire size (AWG)																			
5	18	16	14	12	12	10	10	10	8	8	8	6	6	6	6	6	6	6	6	6
10	14	12	10	10	10	8	6	6	6	6	4	4	4	4	2	2	2	2	2	2
15	12	10	10	8	8	6	6	6	4	4	2	2	2	2	2	1	1	1	1	1
20	10	10	8	6	6	6	4	4	2	2	2	2	1	1	1	0	0	0	0	2/0
25	10	8	6	6	6	4	4	2	2	2	1	1	0	0	0	2/0	2/0	2/0	2/0	3/0
30	10	8	6	6	4	4	2	2	1	1	0	0	0	2/0	2/0	3/0	3/0	3/0	3/0	3/0
40	8	6	6	4	4	2	2	1	0	0	2/0	2/0	3/0	3/0	3/0	4/0	4/0	4/0	4/0	4/0
50	6	6	4	4	2	2	1	0	2/0	2/0	3/0	3/0	4/0	4/0	4/0					
60	6	4	4	2	2	1	0	2/0	3/0	3/0	4/0	4/0	4/0							
70	6	4	2	2	1	0	2/0	3/0	3/0	4/0	4/0									
80	6	4	2	2	1	0	3/0	3/0	4/0	4/0										
90	4	2	2	1	0	2/0	3/0	4/0	4/0											
100	4	2	2	1	0	2/0	3/0	4/0												
24 v																				
5	18	18	18	16	16	14	12	12	12	10	10	10	10	10	8	8	8	8	8	8
10	18	16	14	12	12	10	10	10	8	8	8	6	6	6	6	6	6	6	6	6
15	16	14	12	12	10	10	8	8	6	6	6	6	6	4	4	4	4	4	4	2
20	14	12	10	10	10	8	6	6	6	6	4	4	4	4	2	2	2	2	2	2
25	12	12	10	10	8	6	6	6	4	4	4	4	2	2	2	2	2	2	2	1
30	12	10	10	8	8	6	6	4	4	4	2	2	2	2	2	1	1	1	1	1
40	10	10	8	6	6	6	4	4	2	2	2	2	1	1	1	0	0	0	0	2/0
50	10	8	6	6	6	4	4	2	2	2	1	1	0	0	0	2/0	2/0	2/0	2/0	3/0
60	10	8	6	6	4	4	2	2	1	1	0	0	0	2/0	2/0	3/0	3/0	3/0	3/0	3/0
70	8	6	6	4	4	2	2	1	1	0	0	2/0	2/0	3/0	3/0	3/0	3/0	3/0	4/0	4/0
80	8	6	6	4	4	2	2	1	0	0	2/0	2/0	3/0	3/0	3/0	4/0	4/0	4/0	4/0	4/0
90	8	6	4	4	2	2	1	0	0	2/0	2/0	3/0	3/0	4/0	4/0	4/0	4/0	4/0	4/0	
100	6	6	4	4	2	2	1	0	2/0	2/0	3/0	3/0	4/0	4/0	4/0					

CONVERSION OF AWG TO EUROPEAN STANDARDS

Conductor size (AWG)	Conductor diameter (mm)	Conductor cross-sectional area (mm ²)
25	0.455	0.163
24	0.511	0.205
23	0.573	0.259
22	0.644	0.325
21	0.723	0.412
20	0.812	0.519
19	0.992	0.653
18	1.024	0.823
17	1.15	1.04
16	1.29	1.31
15	1.45	1.65
14	1.63	2.08
13	1.83	2.63
12	2.05	3.31
11	2.30	4.15
10	2.59	5.27
9	2.91	6.62
8	3.26	8.35
7	3.67	10.6
6	4.11	13.3
5	4.62	16.8
4	5.19	21.2
3	5.83	26.7
2	6.54	33.6
1	7.35	42.4
0 (1/0)	8.25	53.4
00 (2/0)	9.27	67.5
000(3/0)	10.40	85.0
0000 (4/0)	11.68	107.2
00000 (5/0)	13.12	135.1
000000 (6/0)	14.73	170.3

1.1 circular mil (CM) \approx 0.0005067 mm²

This Page Intentionally Left Blank

Section 15

FAILURE DIAGNOSIS

	Page
Special Service Tools.....	15-3
Tier 4 (BOSCH) Compression Inspection Procedures	15-4
Measured Value and Troubleshooting	15-6
Quick Reference Table for Troubleshooting.....	15-6

This Page Intentionally Left Blank

SPECIAL SERVICE TOOLS

<p>Compression gauge</p>	<p>For measuring compression pressure YANMAR Part No.129978-92950</p> <p>For detailed dimensions, refer to <i>Compression gauge adapter (129A00-92950)</i> on page 6-22.</p>	
--------------------------	--	--

TIER 4 (BOSCH) COMPRESSION INSPECTION PROCEDURES

1. Warm up the engine.
2. Stop the engine.
3. Remove the high-pressure fuel line assembly.
4. Remove the injector harnesses (couplers) of all cylinders.
5. Remove the injector fuel return hose assembly of all cylinders.
6. Remove the injectors of all cylinders. Fill in the cylinder No. on the injector before removal.
7. Install the injectors and the high-pressure lines of all cylinders in the direction where there is no influence of the inspection operation.
Install the harnesses (couplers) in the injectors.
8. Connect the service tool (SMARTASSIST-Direct) while the engine key is turned ON. Cut the injector fuel injection of all cylinder with the active control mode.
9. Install the special-purpose adapter and the compression gauge to the cylinder you want to measure.
10. Crank and inspect the engine until the display of the compression gauge becomes stable.
11. When the compression inspection is complete, turn OFF the active control, turn OFF the SA-D communication, turn OFF the engine key.
12. Remove the special-purpose adapter and the compression gauge to the cylinder you want to measure.
13. Insert the injectors to the correct cylinders.
Tighten the injectors.
Note: Be sure to install the injector packings to all cylinders.
14. Install the injector fuel return hose assembly of all cylinders.
15. Install the injector harnesses (couplers) of all cylinders.
16. Install the new high-pressure fuel line assembly.
17. Open the cock of the fuel system.
18. Test the engine. Check for the fuel leaks..
Note: Take care not to adhere or mix the foreign matter when you install the injector, rail, and high-pressure fuel line.

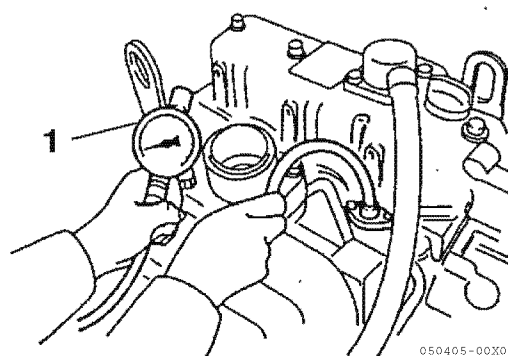

■ Standard compression pressure (reference value)

Engine model	Compression pressure at 250 min ⁻¹		Deviation between cylinders
	Standard	Limit	
3TNV88C 3TNV86CT 4TNV88C 4TNV86CT 4TNV98C 4TNV98CT	3.14 - 3.34 MPa (32 - 34 kgf/cm ²)	2.45 - 2.65 MPa (25 - 27 kgf/cm ²)	0.2 - 0.3 MPa (2 - 3 kgf/cm ²)

■ Engine speed and compression pressure (use for reference)

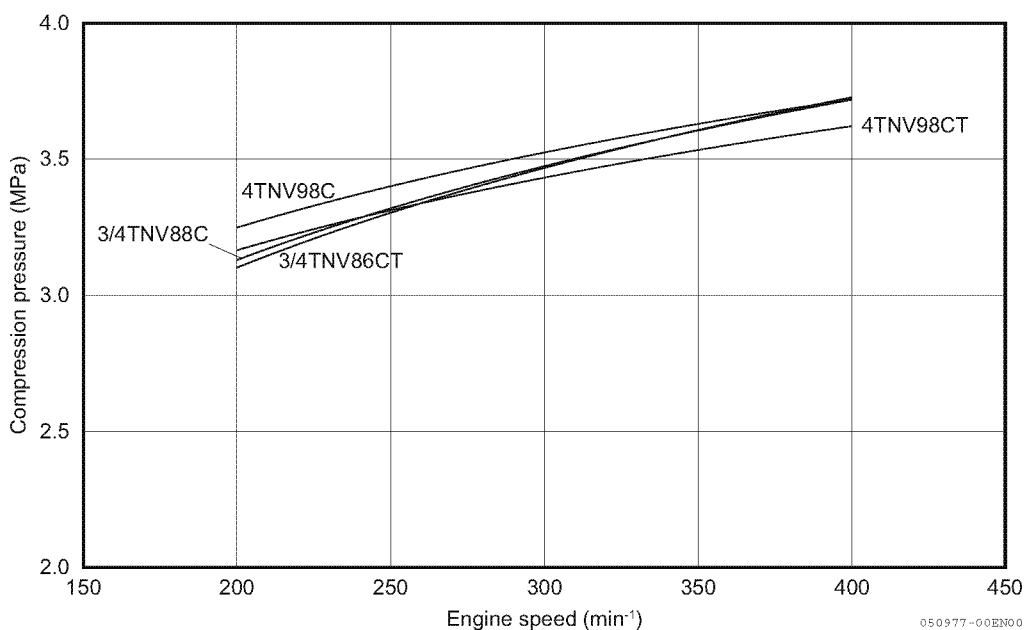

Figure 15-1

MEASURED VALUE AND TROUBLESHOOTING

When the measured compression pressure is below the limit value, inspect each part by referring to the table below.

No.	Item	Cause	Corrective action
1	Air cleaner element	Clogged element	Clean the element.
		Broken element	Replace the element.
		Defect at element seal portion	
2	Valve clearance	Excessive or no clearance	Adjust the valve clearance.
3	Valve timing	Incorrect valve clearance	Adjust the valve clearance.
4	Cylinder head gasket	Gas leak from gasket	Replace the gasket.
			Retighten the cylinder head bolts to the specified torque.
5	Intake/exhaust valve	Sticking valve	Replace the intake/exhaust valve.
	Valve seat	Gas leak due to worn valve seat or foreign matter trapped in valve	Lap the valve seat.
6	Piston	Gas leak due to scratching or wear	Perform honing and use an oversized part.
	Piston ring		
	Cylinder		

QUICK REFERENCE TABLE FOR TROUBLESHOOTING

The following table summarizes the general trouble symptoms and their causes. If any trouble symptom occurs, take corrective action before it becomes a serious problem so as not to shorten the engine service life.

For details of troubleshooting on electronic control (ECU), refer to the SA-D section in Tier 4 Troubleshooting Manual.

Symptoms and conditions of failures	Defective start		Engine stall after start	Defective rotation control			Insufficient engine output		Noise/vibration			Lubricant			Cooling water	Intake	Exhaust			Fuel	Electrics/electronics			Cause	Action	Referenced page number														
	Starter not rotate	Starter rotates	Exhaust fume	Without load	At work	Exhaust color																																		
	ECU indicator lamp not on just after key-on	ECU indicator lamp on just after key-on (2 seconds)	Engine not start (not even initial combustion)																								Engine not start (stall after serial combustion)	Engine starts later than ever	None	Little	Much	Speed change by accelerator not available (constant speed)	Specified speed setting not available	Poor acceleration	Return to low speed not smooth	Hunting	Hunting	Normal	White	Black
Cooling water system	Radiator super cooled																								Thermostat replacement	See Disassembly of Engine Coolant Pump on page 8-8.														
	Insufficient radiator cooling																									Thermostat replacement or check for fan belt loose	See Disassembly of Engine Coolant Pump on page 8-8 or Check and adjust cooling fan V-belt on page 5-9.													
	Insufficient cooling water quantity																									Water leak inspection of cooling water system	See Engine Coolant System Check on page 8-6.													
	Water jacket cracks																									Repair or replacement	See Disassembly of Engine Coolant Pump on page 8-8.													
	Fan belt elongation																									Adjustment of belt tension	See Check and adjust cooling fan V-belt on page 5-9.													
	Thermostat fault																									Inspection or replacement	See Disassembly of Engine Coolant Pump on page 8-8.													
Lubricant system	Incorrect lubricant																									Usage of correct lubricant	See Engine Oil Specifications on page 4-25.													
	Lubricant system leakage																									Repair	See Disassembly of Oil Pump on page 9-8.													
	Insufficient discharge rate of trochoid pump																									Inspection and repair	See Disassembly of Oil Pump on page 9-8.													
	Lubricant filter clogged																									Cleaning or replacement	See Replace engine oil and engine oil filter on page 5-7.													
	Regulator valve fault																									Cleaning, adjustment or replacement	See Disassembly of Oil Pump on page 9-8.													
	Insufficient lubricant quantity																									Replenishment of correct lubricant	See Adding Engine Oil on page 4-26.													
	Excess filling into crankcase																									Engine oil check	See Adding Engine Oil on page 4-26.													
Fuel system	Incorrect fuel																									Usage of correct fuel	See Diesel Fuel Specifications on page 4-22.													
	Water entered into fuel system																									Drainage of fuel filter	See Drain fuel filter/water separator on page 5-10.													
	Fuel filter clogged																									Cleaning or replacement	See Replace element of fuel filter/water separator on page 5-18.													
	Air entered into fuel system																									Bleeding	See Priming the Fuel System on page 4-24.													
	Fuel pipe clogged, cracked																									Cleaning or replacement														
	Insufficient fuel feeding to fuel supply pump																									Check of fuel tank cock, fuel filter, fuel pipe, fuel feed pump														
	Priming not available																									Valve in priming pump pinched dust (disassembled cleaning)	See Fuel System Components on page 7-7.													
	Strainer at feed pump inlet clogged																									Cleaning of strainer														
Sealing defect of fuel tank																										Check of fuel tank and cap, as well as installation of genuine parts														

Symptoms and conditions of failures	Defective start		Engine stall after start	Defective rotation control			Insufficient engine output	Noise/vibration	Lubricant	Cooling water	Intake	Exhaust		Fuel	Electrics/electronics			Action	Referenced page number																					
	Starter not rotate	Starter rotates	Exhaust fume	Without load	At work	Exhaust color							At work																											
	ECU indicator lamp not on just after key-on	ECU indicator lamp on just after key-on (2 seconds)	Engine not start (not even initial combustion)										Engine not start (stall after serial combustion)	Engine starts later than ever						None	Little	Much	Speed change by accelerator not available (constant speed)	Specified speed setting not available	Poor acceleration	Return to low speed not smooth	Hunting	Hunting	Normal	White	Black	Knocking noise at combustion too high	Combustion noise uneven	Noise other than combustion from engine	Engine vibration too big	Lubricant consumption too much	Lubricant diluted with fuel	Lubricant mixed with water	Oil pressure too low (oil pressure lamp on)	Overheated (water temperature lamp on)
Intake	Air filter clogged																		Cleaning of air filter	See Clean air cleaner element on page 5-15.																				
	Engine operation at high temperature or high land																		Consideration of matching output reduction with load																					
	Exhaust pipe clogged																		Cleaning of exhaust pipe																					
Electric system	Fuse meltdown, disconnection	○	○																Inspection and replacement of fuse Repair or replacement of harness	For harness inspection method, see Failure Diagnosis on page 15-1.																				
	Starter fault		○	○															Repair or replacement of starter	See Starter Motor on page 11-8.																				
	Alternator fault			○															Repair or replacement of alternator	See Removal of Alternator on page 12-10.																				
	Wiring disconnection	○	○	○															Repair or replacement of harness disconnection																					
	Wiring short-circuit (insulator broken), electric power load of added device too big	○																	Inspection, repair or replacement of harnesses Review of added devices																					
	Battery voltage descent		○	○															Inspection and charging of battery	See Check battery on page 5-12.																				
	Key switch fault, disconnection	○																	Repair or replacement of harness Key switch replacement	For harness inspection method, see Failure Diagnosis on page 15-1.																				
	Instantaneous interruption of key switch			○															Key switch replacement																					
	Failure, disconnection, short-circuit of starter relay		○																Repair or replacement of harness Replacement of starter relay	For harness inspection method, see Failure Diagnosis on page 15-1.																				
	Main relay fault (Error other than contact sticking that ECU can't detect)	○																	Repair or replacement of harness Replacement of main relay	For harness inspection method, see Failure Diagnosis on page 15-1.																				
	Actuator relay fault (Error of contact that ECU can't detect)		○	○															Replacement of actuator relay																					
	The start assist relay may be faulty. (Error of contact that ECU can't detect)			○	○														Replacement of start assist relay																					
	Accelerator sensor signal error (Error at which level ECU can't detect)					○		○	○										Repair or replacement of accelerator sensor	Monitor the accelerator sensor by the diagnosis tool.																				
	Water temperature sensor signal error (Error at which level ECU can't detect)			○	○			○	○										Replacement of water temperature sensor	Monitor the cooling water temperature by the diagnosis tool.																				
	Speed sensor signal error (Cause of noise etc. that ECU can't detect)			○	○	○		○	○										Cleaning or replacement of speed sensor Repair or replacement of fuel supply pump	Monitor the engine rotational speed by the diagnosis tool.																				
	Rack position sensor signal error (Level that ECU can't detect)			○	○			○	○										Repair or replacement of fuel supply pump	Monitor the rack position sensor signal by the diagnosis tool.																				
Operation defect of rack actuator (Level that ECU can't detect)			○	○			○	○										Repair or replacement of fuel supply pump	Check the movement of rack actuator by the diagnosis tool.																					
ECU failure lamp disconnected																		Replace the lamp. Repair or replace the harness.																						
ECU faulty (ECU self diagnosis failure)	○	○					○											Replace the ECU.																						

Symptoms and conditions of failures	Defective start		Engine stall after start	Defective rotation control			Insufficient engine output	Noise/vibration	Lubricant	Cooling water	Intake	Exhaust	Fuel	Electrics/electronics	Action	Referenced page number																								
	Starter not rotate	Starter rotates	Exhaust fume	Without load	At work	Exhaust color						At work																												
	ECU indicator lamp not on just after key-on	ECU indicator lamp on just after key-on (2 seconds)	Engine not start (not even initial combustion)	Engine not start (stall after serial combustion)	Engine starts later than ever	None	Little	Much	Speed change by accelerator not available (constant speed)	Specified speed setting not available	Poor acceleration	Return to low speed not smooth	Hunting	Hunting			Normal	White	Black	Knocking noise at combustion too high	Combustion noise uneven	Noise other than combustion from engine	Engine vibration too big	Lubricant consumption too much	Lubricant diluted with fuel	Lubricant mixed with water	Oil pressure too low (oil pressure lamp on)	Overheated (water temperature lamp on)	Water temperature too low	Pressure down (air cleaner lamp on)	Pressure up	White exhaust color	Black exhaust color	Blow-by too much	Exhaust temperature up	Fuel consumption too much	Fuel mixed with water (oil-water separator lamp on)	Fuel filter contaminated too early	Battery charge defect (charge lamp on)	ECU indicator lamp flashing
Cause	ECU control function operating																Not failure Implement regular usage	Check the causes of engine stop or starter restraint by a diagnosis tool.																						
	Disconnection/short-circuit of water temperature sensor																Repair or replacement of harness Replacement of water temperature sensor	For harness inspection method, see <i>Failure Diagnosis on page 15-1</i> .																						
	Disconnection/short-circuit of accelerator sensor																Repair or replacement of harness Replacement of accelerator sensor	For harness inspection method, see <i>Failure Diagnosis on page 15-1</i> .																						
	Speed sensor signal error																Repair or replacement of harness Repair or replacement of fuel supply pump	For harness inspection method, see <i>Failure Diagnosis on page 15-1</i> .																						
	Engine over speed																Check operating machine's driving. Check speed sensor signal.																							
	CAN communication error																Repair or replacement of harness ECU Replacement	For harness inspection method, see <i>Failure Diagnosis on page 15-1</i> .																						
	Disconnection/short-circuit of EGR valve motor																Repair or replacement of harness Replacement of EGR valve	For harness inspection method, see <i>Failure Diagnosis on page 15-1</i> .																						
	Disconnection/short-circuit of start assist relay																Repair or replacement of harness Relay replacement	For harness inspection method, see <i>Failure Diagnosis on page 15-1</i> .																						
	Main relay "OFF" not available																Relay replacement																							
	Malfunction by ECU self-diagnosis																ECU Replacement																							

YANMAR

Head Office:

YANMAR CO., LTD.

Umeda Gate Tower 1-9 Tsurunocho, kita-ku, Osaka, Japan
<http://www.yanmar.co.jp>

Yanmar America Corporation

101 International Parkway
Adairsville, GA 30103, U.S.A.
TEL: +1-770-877-9894 FAX: +1-770-877-9009
<http://www.yanmar.com>

Yanmar Europe B.V.

Brugplein11, 1332 BS Almere -de Vaart,
The Netherlands.
TEL: +31-36-5493200 FAX: +31-36-5493209
<http://www.yanmar.nl>

Yanmar Asia (Singapore) Corporation Pte. Ltd.

4 Tuas Lane, Singapore 638613
TEL: +65-68615077 FAX: +65-68611509
<http://www.yanmar.co.jp/yasc/>

Yanmar Engine (Shanghai) Corporation Ltd.

10F, E-Block POLY PLAZA, No.18 Dongfang Road,
Pudong Shanghai, CHINA P.R.C 200120
TEL: +86-21-6880-5090 FAX: +86-21-6880-8682
<http://www.yanmar-sha.com>

Yanmar South America Industria De Maquinas Ltda.

Av. Presidente Vargas 1400, Indaiatuba, S.P., Brazil, CEP: 13338-901
TEL: +55-19-3801-9224 FAX: +55-19-3875-3899, 2241
<http://www.yanmar.com.br>

SERVICE MANUAL

TNV Series

1st edition: March 2012

1st edition 1st rev. : December 2012

Issued by: YANMAR CO., LTD.

Edited by: YANMAR TECHNICAL SERVICE CO., LTD.

YANMAR

YANMAR CO., LTD.